

GB

Operating Manual

WAGNER®

Finish 230 AC Compact

Spray System

Models:

0524009

0524019

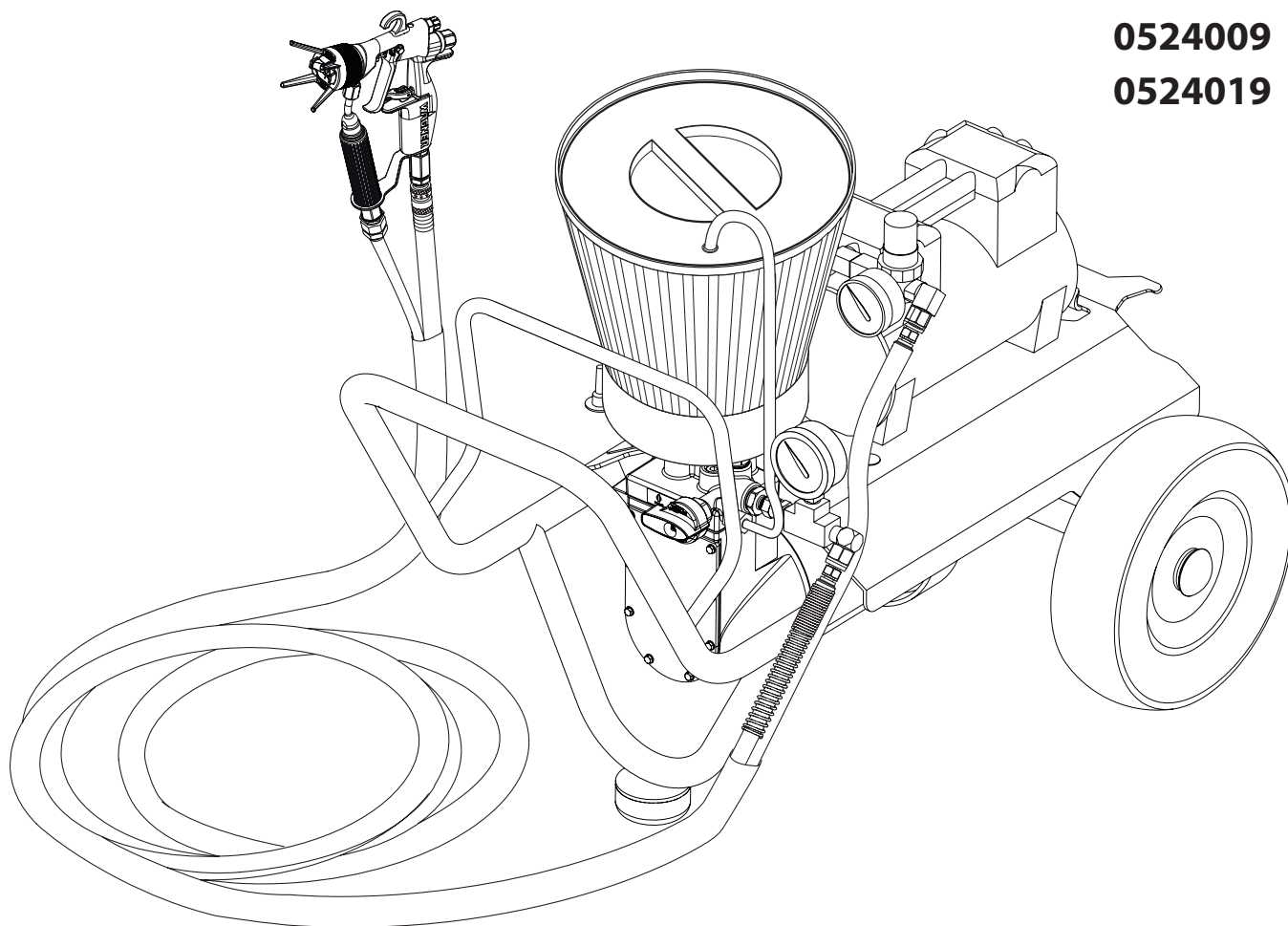

Warning!

Attention: Danger of injury by injection!
AirCoat units develop extremely high spraying pressures.



1

Never put your fingers, hands or any other parts of the body into the spray jet!

Never point the spray gun at yourself, other persons or animals.

Never use the spray gun without safety guard.

Do not treat a spraying injury as a harmless cut. In case of injury to the skin through coating materials or solvents, consult a doctor immediately for quick and expert treatment. Inform the doctor about the coating material or solvent used.

2

The operating instructions state that the following points must always be observed before starting up:

1. Faulty units must not be used.
2. Secure WAGNER spray gun using the safety catch on the trigger.
3. Check allowable operating pressure of high-pressure hose and spray gun.
4. Check all connections for leaks.

3

The instructions regarding regular cleaning and maintenance of the unit must be strictly observed.

Before any work is done on the unit or for every break in work the following rules must be observed:

1. Release the pressure from spray gun and hose.
2. Secure the WAGNER spray gun using the safety catch on the trigger.
3. Switch off unit.

Be safety conscious!







Contents

	Page		Page
1. Safety regulations for AirCoat Spraying	4/5	8. Maintenance	13
1.1 Explanation of symbols used	4	8.1 Removing and cleaning the inlet valve.....	13
1.1 Earthing Instructions.....	6	8.2 Removing and cleaning the outlet valve.....	14
1.2 Technical Data.....	6	9. Electrical Schematic	14
2. General Description	6	10. Troubleshooting	15
2.1 System diagram	6	Spare Parts List	16
3. Setup	7	Main assembly.....	16
4. Operation	8	Diaphragm pump.....	17
4.1 Preparing to Prime.....	8	Cart assembly	18
4.2 Priming with hopper.....	8	Hopper assembly	18
4.3 Priming with the optional suction set	9	Pump head	19
5. Spraying	10	Optional suction set	19
5.1 Spraying in AirCoat Mode	11	WAGNER-Service companies	20
5.2 Spraying in Airless Mode	11	Important notes on product liability	21
5.3 Pressure Relief Procedure.....	11	3+2 years guarantee for professional finishing	21
6. Spraying Technique	11	CE Declaration of Conformity	23/24
7. Cleanup	12		
7.1 Overnight storage.....	12		
7.2 Long-Term storage	12		
7.3 Clearing the paint hopper.....	12		
7.4 Clearing the optional suction set	12		
7.5 Clearing the spray hose.....	12		
7.6 Final cleanup.....	13		

1. Safety regulations for AirCoat spraying

1.1 Explanation of symbols used

This manual contains information that must be read and understood before using the equipment. When you come to an area that has one of the following symbols, pay particular attention and make certain to heed the safeguard.

	This symbol indicates a potential hazard that may cause serious injury or loss of life. Important safety information will follow.
	This symbol indicates a potential hazard to you or to the equipment. Important information that tells how to prevent damage to the equipment or how to avoid causes of minor injuries will follow.
	Danger of skin injection
	Danger of fire from solvent and paint fumes
	Danger of explosion from solvent, paint fumes and incompatible materials
	Danger of injury from inhalation of harmful vapors
	Notes give important information which should be given special attention.



HAZARD: INJECTION INJURY

A high pressure stream produced by this equipment can pierce the skin and underlying tissues, leading to serious injury and possible amputation.

DO NOT TREAT AN INJECTION INJURY AS A SIMPLE CUT! Injection can lead to amputation. See a physician immediately.

The maximum operating range of the unit is 193 bar (19.3 MPa, 2800 PSI) fluid pressure.

PREVENTION:

- NEVER aim the gun at any part of the body.
- NEVER allow any part of the body to touch the fluid stream. DO NOT allow body to touch a leak in the fluid hose.
- NEVER put your hand in front of the gun. Gloves will not provide protection against an injection injury.
- ALWAYS lock the gun trigger, shut the fluid pump off and release all pressure before servicing, cleaning the tip guard, changing tips, or leaving unattended. Pressure will not be released by turning off the engine. The PRIME/SPRAY valve or pressure bleed valve must be turned to their appropriate positions to relieve system pressure. Refer to the PRESSURE RELIEF PROCEDURE described in this manual.
- ALWAYS keep tip guard in place while spraying. The tip guard provides some protection but is mainly a warning device.
- ALWAYS remove the spray tip before flushing or cleaning the system.
- The paint hose can develop leaks from wear, kinking and abuse. A leak can inject material into the skin. Inspect the hose before each use.
- NEVER use a spray gun without a working trigger lock and trigger guard in place.
- All accessories must be rated at or above the maximum operating pressure range of the sprayer. This includes spray tips, guns, extensions, and hose.

NOTE TO PHYSICIAN:

Injection into the skin is a traumatic injury. It is important to treat the injury as soon as possible. DO NOT delay treatment to research toxicity. Toxicity is a concern with some coatings injected directly into the blood stream. Consultation with a plastic surgeon or reconstructive hand surgeon may be advisable.

**HAZARD: EXPLOSION OR FIRE**

Solvent and paint fumes can explode or ignite. Severe injury and/or property damage can occur.

PREVENTION:

- Provide extensive exhaust and fresh air introduction to keep the air within the spray area free from accumulation of flammable vapors.
- Avoid all ignition sources such as static electricity sparks, electrical appliances, flames, pilot lights, hot objects, and sparks from connecting and disconnecting power cords or working light switches.
- Do not smoke in spray area.
- Fire extinguisher must be present and in good working order.
- Place sprayer at least 6.1 m (20 feet) from the spray object in a well ventilated area (add more hose if necessary). Flammable vapors are often heavier than air. Floor area must be extremely well ventilated. The pump contains arcing parts that emit sparks and can ignite vapors.
- The equipment and objects in and around the spray area must be properly grounded to prevent static sparks.
- Use only conductive or earthed high pressure fluid hose. Gun must be earthed through hose connections.
- Power cord must be connected to a grounded circuit (electric units only).
- Always flush unit into separate metal container, at low pump pressure, with spray tip removed. Hold gun firmly against side of container to ground container and prevent static sparks.
- Follow material and solvent manufacturer's warnings and instructions. Be familiar with the coating material's MSDS sheet and technical information to ensure safe use.
- The unit must be connected to an earthed object. Use the green earthing wire to connect the unit to a water pipe, steel beam, or other electrically earthed surface.
- Do not use materials with a flashpoint below 21° C (70° F). Flashpoint is the temperature at which a fluid can produce enough vapors to ignite.
- Plastic can cause static sparks. Never hang plastic to enclose spray area. Do not use plastic drop cloths when spraying flammable materials.
- Use lowest possible pressure to flush equipment.

**HAZARD: EXPLOSION HAZARD DUE TO INCOMPATIBLE MATERIALS**

Will cause severe injury or property damage.

PREVENTION:

- Do not use materials containing bleach or chlorine.
- Do not use halogenated hydrocarbon solvents such as methylene chloride and 1,1,1 - trichloroethane. They are not compatible with aluminum and may cause an explosion. If you are unsure of a material's compatibility with aluminum, contact your coating's supplier.

**HAZARD: HAZARDOUS VAPORS**

Paints, solvents, insecticides, and other materials can be harmful if inhaled or come in contact with body. Vapors can cause severe nausea, fainting, or poisoning.

PREVENTION:

- Use a respirator or mask if vapors can be inhaled. Read all instructions supplied with the mask to be sure it will provide the necessary protection.
- Wear protective eyewear.
- Wear protective clothing as required by coating manufacturer.

**HAZARD: GENERAL**

This product can cause severe injury or property damage.

PREVENTION:

- Read all instructions and safety precautions before operating equipment.
- Follow all appropriate local, state, and national codes governing ventilation, fire prevention, and operation.
- Pulling the trigger causes a recoil force to the hand that is holding the spray gun. The recoil force of the spray gun is particularly powerful when the tip has been removed and a high pressure has been set on the airless pump. When cleaning without a spray tip, set the pressure control knob to the lowest pressure.
- Use only manufacturer authorized parts. User assumes all risks and liabilities when using parts that do not meet the minimum specifications and safety devices of the pump manufacturer.
- Before each use, check all hoses for cuts, leaks, abrasion or bulging of cover. Check for damage or movement of couplings. Immediately replace the hose if any of these conditions exist. Never repair a paint hose. Replace it with another earthed high-pressure hose.
- Make sure power cord, air hose and spray hoses are routed in such a manner to minimize slip, trip and fall hazard
- ALWAYS follow the material manufacturer's instructions for safe handling of paint and solvents.
- Do not use this unit in workshops that are covered under the explosion prevention regulations.
- Clean up all material and solvent spills immediately to prevent slip hazard.
- Always unplug cord from outlet before working on equipment (electric units only).
- Always keep the power cord plug in sight during usage to prevent any accidental shutdown or startup.
- Wear ear protection. This unit can produce noise levels above 85 dB(A).
- Never leave this equipment unattended. Keep away from children or anyone not familiar with the operation of airless equipment.
- Do not move unit while hopper is filled or while unit is running.
- Do not spray on windy days.

1.2 Earthing Instructions

Electric models must be earthed. In the event of an electrical short circuit, earthing reduces the risk of electric shock by providing an escape wire for the electric current. This product is equipped with a cord having an earthing wire with an appropriate earthing plug. The plug must be plugged into an outlet that is properly installed and earthed in accordance with all local codes and ordinances.



DANGER — Improper installation of the earthing plug can result in a risk of electric shock. If repair or replacement of the cord or plug is necessary, do not connect the green earthing wire to either blade terminal. The wire with insulation having a green outer surface with or without yellow stripes is the earthing wire and must be connected to the earthing pin.

Check with a qualified electrician or serviceman if the earthing instructions are not completely understood, or if you are in doubt as to whether the product is properly earthed. Do not modify the plug provided. If the plug will not fit the outlet, have the proper outlet installed by a qualified electrician.



Caution – The power cord for this equipment acts as an emergency stop/emergency switching off device. The power cord must be placed near an easily accessible, unobstructed socket-outlet.

2. General Description

This fine finish spray system is versatile enough to use for low pressure fine finish work as well as high pressure airless spraying. The system includes a diaphragm paint pump and an air compressor that work together to provide this versatility.

2.1 System Diagram

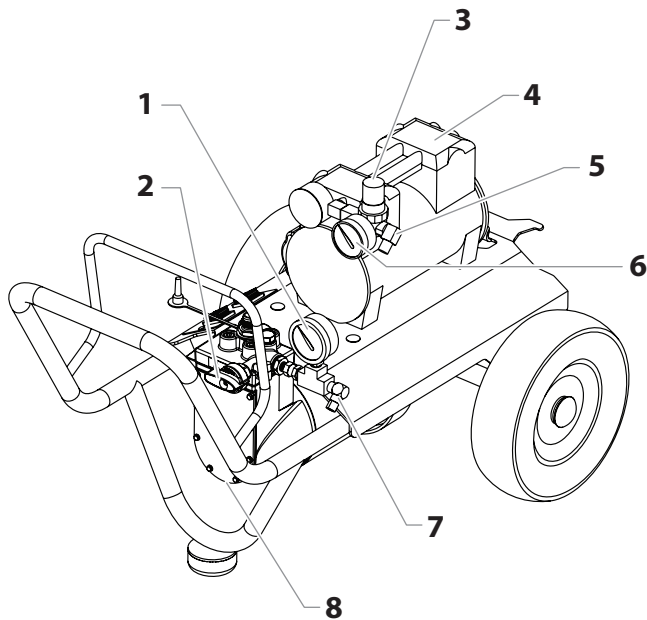

- 1 Material pressure gauge
- 2 PRIME/SPRAY valve
- 3 Air pressure regulator
- 4 Air compressor
- 5 Air outlet fitting
- 6 Air pressure gauge
- 7 Material outlet fitting
- 8 Diaphragm pump
- 9 Compressor ON/OFF switch
- 10 Diaphragm pump ON/OFF switch
- 11 Pressure control knob

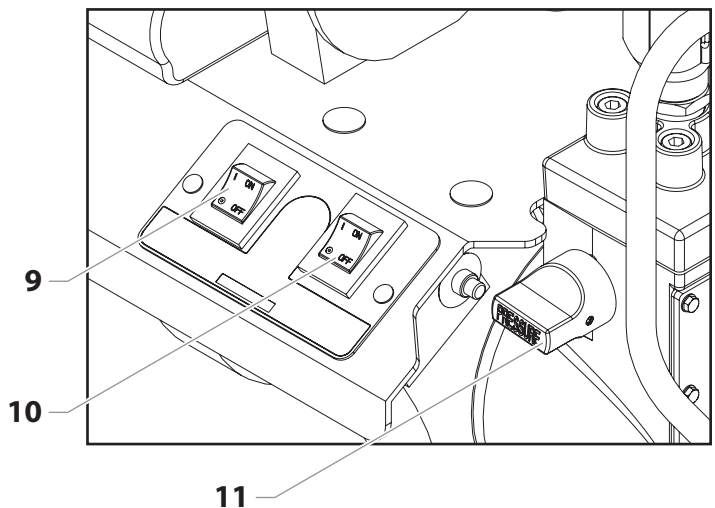

1.3 Technical Data

Weight	: 40.6 kg (89.5 lbs.)
Capacity	: Up to 1.69 liters (0.45 gallon) per minute
Power requirement	:
Model 0524009	: 10 amp minimum circuit on 230-240 VAC, 50 Hz current, 1 PH
Model 0524019	: 10 amp minimum circuit on 230 VAC, 50 Hz current, 1 PH
Power consumption	: 1000W
Short circuit current (SCC)	: 8 amp
Max. fluid pressure	: Up to 193 bar (19 MPa, 2800 PSI)
Max. air pressure	: Up to 2.1 bar (0.21 MPa, 30 psi)
Dimensions	: 81.3 cm x 53.3 cm x 55.9 cm (32" L x 21" W x 22" H)
Noise level	: less than 70dB (A).
Vibration levels	:
Spray gun	: < 2.5m/s ²
Cart handle	: 6.5m/s ² when unit is operating

3. Setup

Use this procedure to set up the spray system.

1. Make sure the diaphragm pump ON/OFF switch and the compressor ON/OFF switch are in the OFF position.
2. Make sure the pressure control knob is turned fully counterclockwise to its lowest pressure setting.
3. Using a wrench, attach a minimum of 7.5 m of 6 mm nylon airless spray hose to the material outlet fitting on the pump. Tighten securely.
4. Attach the air hose to the air outlet fitting on the compressor. Tighten securely.
5. Lock the gun by flipping the trigger lock into lock position (see spray gun manual).



Make sure to read the spray gun's instruction manual in order to be familiar with all of its functions and corresponding safety information.

6. Attach the spray hose to the material inlet fitting on the spray gun. Using two wrenches (one on the gun and one on the hose), tighten securely.



Make sure all airless hoses and spray guns are electrically grounded and rated for at least 193 bar (19 MPa, 2800 PSI) fluid pressure.

7. Attach the air hose coupling to the air inlet fitting on the spray gun. Attach the air hose to the coupling. Tighten securely.



Reversing the hose connections could result in serious injury. Make sure the airless spray hose is connected from the diaphragm pump to the material inlet fitting on the gun and the air hose is connected from the compressor to the air inlet fitting on the gun.

8. Make sure the electrical service is 10 amp minimum.
9. Plug the power cord into a properly grounded outlet at least 7.5 m from the spray area.

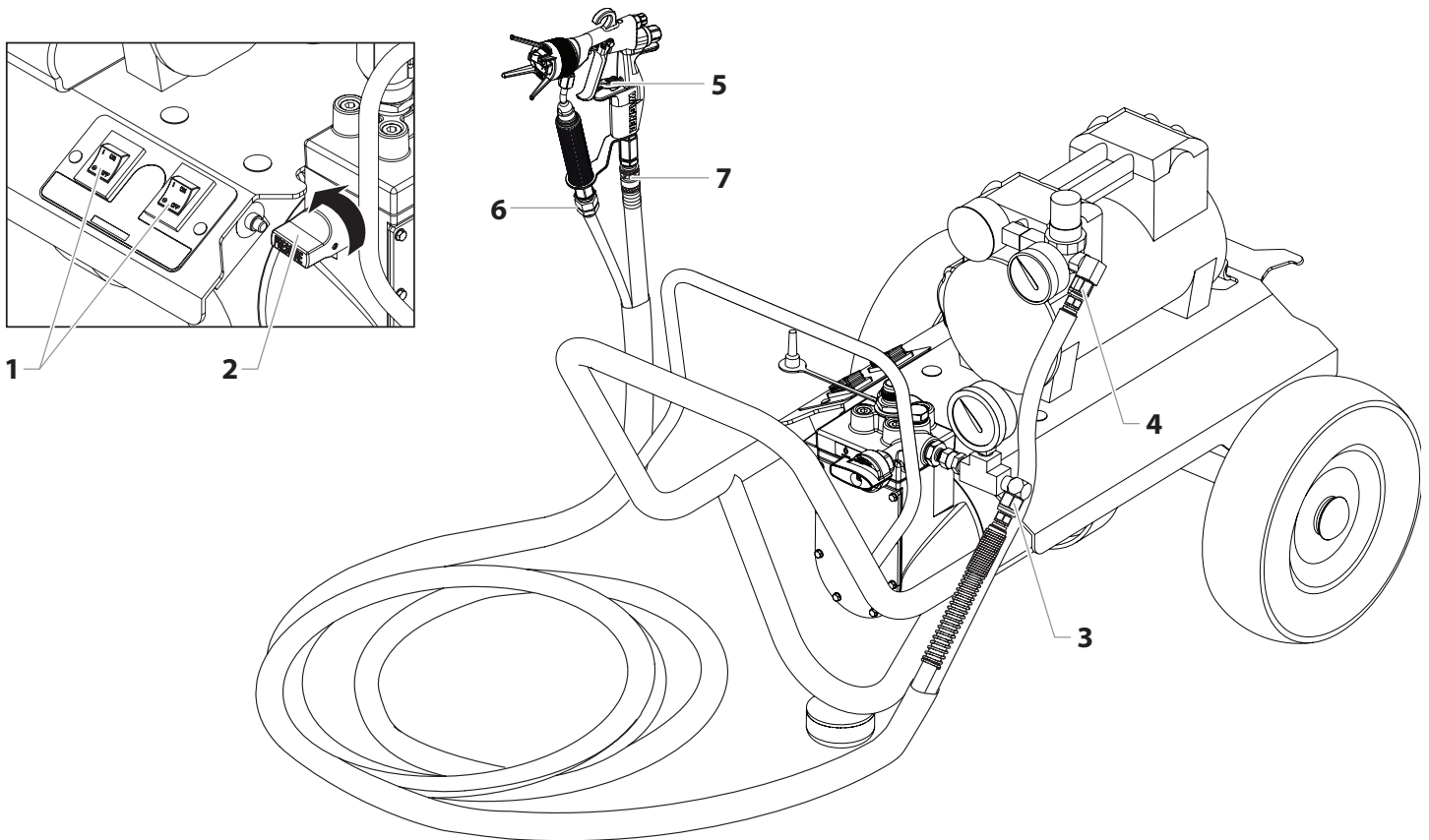

4. Operation

Use the following procedures to operate the spray system.

4.1 Preparing to Prime

1. Fill the inlet valve with water or with a light household oil.
2. Make sure that the PRIME/SPRAY valve is set to PRIME and that the pressure control knob is turned counterclockwise to its lowest pressure setting.
3. Turn on the pump by moving the pump ON/OFF switch to the ON position.
4. Increase the pressure by turning the pressure control knob clockwise 1/2 turn.
5. Force the inlet valve to open and close by pushing on it with a screwdriver or the eraser end of a pencil. It should move up and down about 1.5 mm. Continue until water or oil is sucked into the pump. This will wet the moving parts and break loose any old paint residue.
6. Put the palm of your hand over the inlet. Turn the pressure control knob clockwise to its maximum setting. You should feel suction coming from the inlet valve. If you do not, refer to the "Removing and Cleaning the Outlet Valve" procedure in the Maintenance section.
7. Turn the pressure control knob counterclockwise to the minimum pressure setting.
8. Turn the pump ON/OFF switch to OFF.

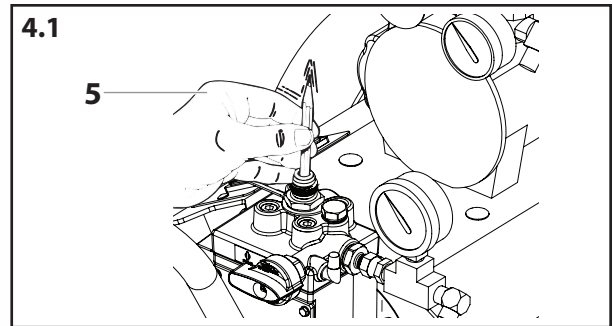
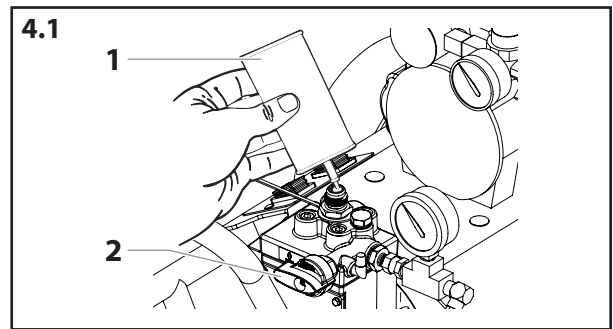

4.2 Priming with Hopper Assembly

1. Attach the hopper assembly to the pump.
 - a. Screw the return tube fitting into the return tube port on the side of the pump.

i Do not over-tighten. Hand tighten only. Some threads will be visible even when fully tightened.

- b. Thread the return hose onto the return hose fitting on the pump.
- c. Turn the paint hopper clockwise to thread it onto the inlet valve. Continue to turn the paint hopper until it is secure on the inlet valve.

i Make sure the threads are straight and the hopper turns freely on the inlet valve. Do not cross-thread.

- d. Place the filter screen into the bottom of the paint hopper and snap it in position.
 - e. Make sure that the motor ON/OFF switch is turned to OFF.
 - f. Place the straight end of the return tube into the return tube fitting.
 - g. Thread the nut on the return tube fitting and tighten until the return tube is secure.
 - h. Place the hook end of the return tube into the hole in the paint hopper cover.
2. Turn the pressure control knob counterclockwise to its lowest pressure setting.
 3. Remove the paint hopper cover and fill the paint hopper with material or place the suction set into a bucket of material.
 4. Turn the PRIME/SPRAY valve to PRIME.
 5. Move the motor ON/OFF switch to ON.
 6. Turn the pressure control knob clockwise to between half and full pressure. Let the unit prime 1 to 2 minutes after material begins to flow through the return tube.

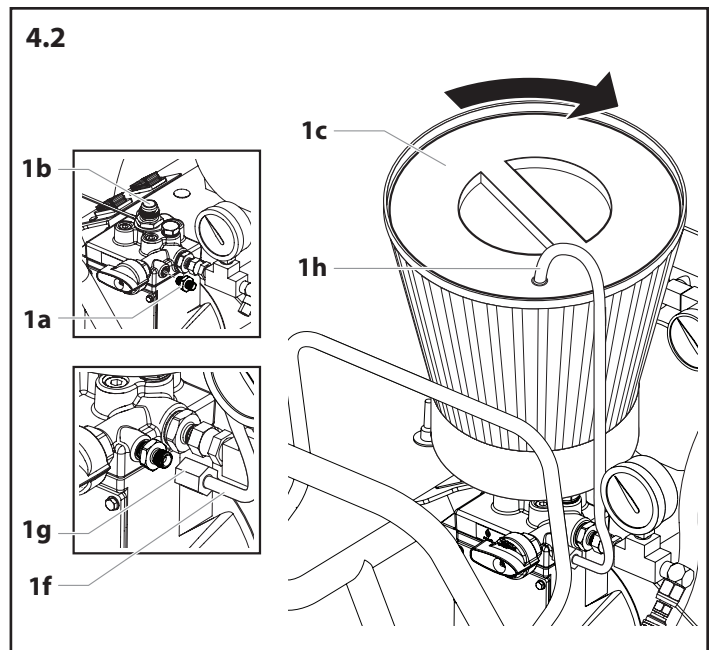

Attention

Always reduce the pressure to zero by triggering the spray gun before changing the position of the PRIME/SPRAY valve. Failure to do so may cause damage to the paint pump diaphragm.

If the pressure control knob is reduced to zero and the PRIME/SPRAY valve is still on SPRAY while the pump is operating, there will be high pressure in the hose and spray gun until the PRIME/SPRAY valve is turned to PRIME or until the spray gun is triggered to relieve the pressure.

4.3 Priming with Optional Suction Set (P/N 0508194A)

1. Attach the suction set to the pump.
 - a. Remove the hopper return tube fitting. Screw the suction set return tube fitting into the return tube port on the side of the pump.



Do not over-tighten. Hand tighten only. Some threads will be visible even when fully tightened.

- b. Align the nut on the suction set with the threaded inlet valve on the pump block.
- c. Thread the suction hose onto the inlet valve on the pump.



Make sure the threads are straight and the suction set fitting turns freely on the inlet valve. Do not cross-thread.

- d. Thread the return tube onto the return tube fitting on the pump.
2. Place the suction set into a container of paint.
 3. Turn the pressure control knob counterclockwise to the minimum pressure setting.



Attention

Always reduce the pressure to zero by triggering the spray gun before changing the position of the PRIME/SPRAY valve. Failure to do so may cause damage to the paint pump diaphragm.

4. Turn the PRIME/SPRAY valve to PRIME.
5. Move the pump ON/OFF switch to the ON position.
6. Turn the pressure control knob clockwise to between half and full pressure. Let the unit prime 1 to 2 minutes after paint begins to flow through the return hose until no bubbles are present.
7. Turn the pressure control knob counterclockwise to the minimum pressure setting.
8. Move the pump ON/OFF switch to the OFF position.



Attention

If the pressure control knob is reduced to zero and the PRIME/SPRAY valve is still on SPRAY while the pump is operating, there will be high pressure in the hose and spray gun until the PRIME/SPRAY valve is turned to PRIME or until the spray gun is triggered to relieve the pressure.

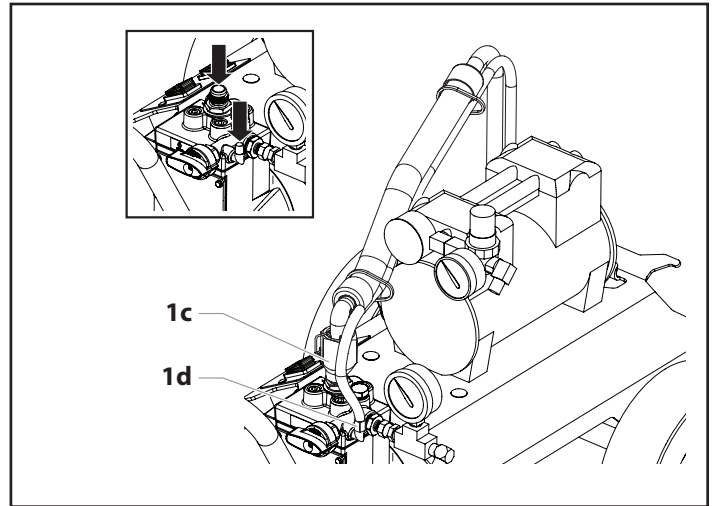

5. Spraying

The AirCoat spray system has two different painting modes. The AirCoat mode is used for fine finish work with low to medium viscosity materials (oil, stains, lacquers, etc...). The airless mode is used for general painting with high viscosity materials (latex).

5.1 Spraying in AirCoat mode

Use the AirCoat mode for low-pressure fine finish work (recommended pump pressure up to 69 bar (6.9 MPa, 1000 PSI).

1. Make sure that the airless spray hose is free of kinks and clear of objects with sharp cutting edges.
2. Turn the pressure control knob counterclockwise to its lowest setting.
3. Turn the compressor air pressure regulator (b) counterclockwise to its lowest setting.
4. Move the compressor ON/OFF switch to the ON position.
5. Move the pump ON/OFF switch to the ON position.
6. Turn the PRIME/SPRAY valve to SPRAY.
7. Turn the pressure control knob clockwise until the material pressure gauge (a) reads 27.5 bar (2.7 MPa, 400 PSI). The paint hose should stiffen as paint begins to flow through it.
8. Turn the air pressure regulator (b) clockwise until the air pressure gauge (c) reads 1.3 bar (0.13 MPa, 20 PSI).

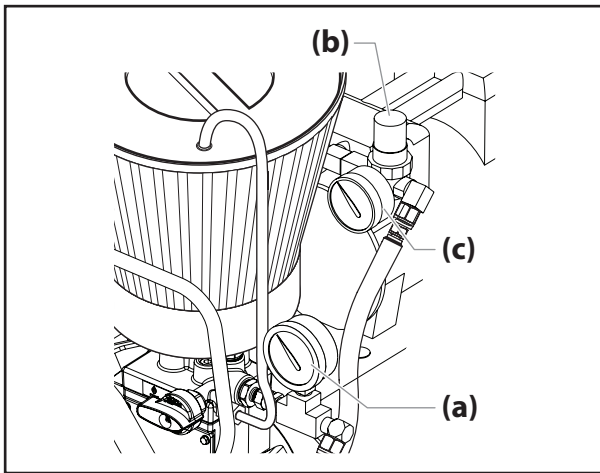

9. Unlock the spray gun gun.
10. Trigger the spray gun to bleed air out of the material hose.
11. When material reaches the spray tip, spray a test area to check the spray pattern.
12. Adjust the spray pattern to the desired size and atomization.
 - Use the pressure control knob to control the flow of paint to the gun.
 - Use the air pressure regulator to control the amount of atomization air available to the gun.
 - Use the pattern adjustment knob on the gun to fine tune the spray pattern.



Refer to the spray gun Owner's Manual for information on the operation of the gun.

5.2 Spraying in Airless Mode

Use the airless mode for general high-pressure spraying (pump pressure from 34.4 bar (3.4 MPa, 500 psi) to 193 bar (19.3 MPa, 2800 PSI).

1. Make sure that the airless spray hose is free of kinks and clear of objects with sharp cutting edges.
2. Turn the pressure control knob (d) counterclockwise to its lowest setting.
3. Turn the PRIME/SPRAY valve (e) to SPRAY.

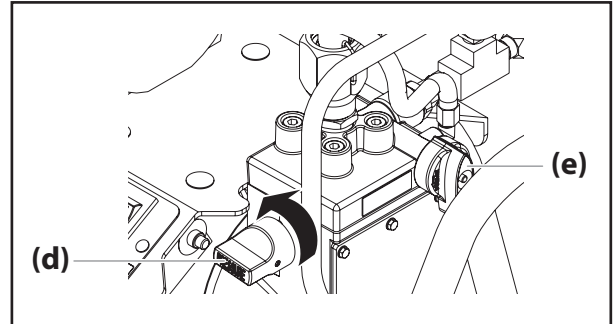

4. Move the pump ON/OFF switch to the ON position.
5. Make sure the compressor ON/OFF switch is in the OFF position.
6. Turn the pressure control knob clockwise to its highest setting. The paint hose should stiffen as paint begins to flow through it.
7. Unlock the gun by turning the gun lock nut counter-clockwise (when looking from the back of the gun) three full turns. This opens the material valve in the gun.
8. Trigger the spray gun to bleed air out of the material hose.
9. When material reaches the spray tip, spray a test area to check the spray pattern.
10. Use the lowest pressure setting necessary to get a good spray pattern.
 - a. If the pressure is set too high, the spray pattern will be too light.
 - b. If the pressure is set too low, tailing will appear or the paint will spatter out in "gobs" rather than in a fine spray.

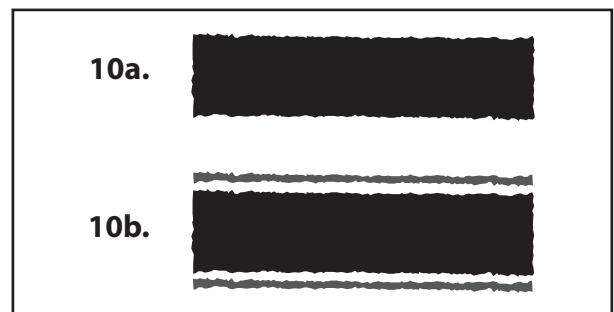

5.3 Pressure Relief Procedure



Be sure to follow the pressure relief procedure when shutting the unit down for any purpose, including servicing or adjusting any part of the spray system, changing or cleaning spray tips, or preparing for cleanup.

1. Turn the pressure control knob counterclockwise to its lowest setting.
2. Turn the PRIME/SPRAY valve to the PRIME position.
3. Trigger the gun to remove any pressure that still may be in the hose.
4. Lock the gun by turning the gun lock nut clockwise (when looking from the back of the gun) until it stops. This closes the material valve in the gun.



Injection hazard. Do not spray without the tip guard in place. NEVER trigger the gun unless the tip is completely turned to either the spray or the unclog position. ALWAYS engage the gun trigger lock before removing, replacing or cleaning tip.

6. Spraying Technique

The key to a good paint job is an even coating over the entire surface. Keep your arm moving at a constant speed and keep the spray gun at a constant distance from the surface. The best spraying distance is 25 to 30 cm between the spray tip and the surface.

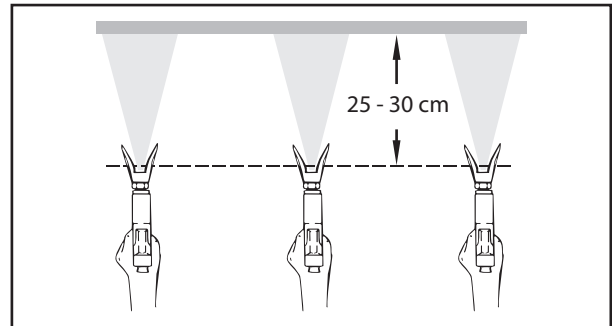

Keep the spray gun at right angles to the surface. This means moving your entire arm back and forth rather than just flexing your wrist.

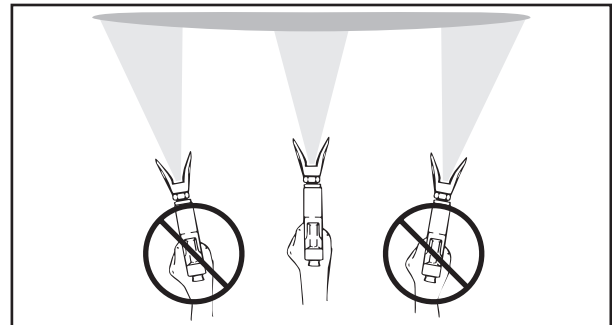

Keep the spray gun perpendicular to the surface, otherwise one end of the pattern will be thicker than the other.

Trigger gun after starting the stroke. Release the trigger before ending the stroke. The spray gun should be moving when the trigger is pulled and released. Overlap each stroke by about 30%. This will ensure an even coating.

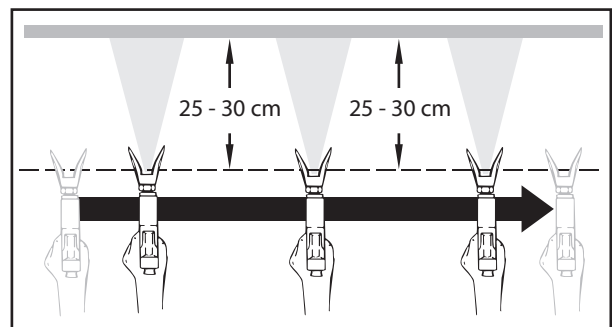

When finished spraying, perform Pressure Relief Procedure.

If you expect to be away from your spray project for more than 1 hour, follow the Overnight Storage procedure described in the Cleanup section of this manual.

7. Cleanup

7.1 Overnight Storage

Shutdown

1. Turn the pressure control knob counterclockwise to the minimum setting.
2. Turn the PRIME/SPRAY valve to PRIME.
3. Move the pump ON/OFF switch to the OFF position.
4. Move the compressor ON/OFF switch to the OFF position.
5. Wait a couple seconds, then trigger the gun into the material container to release built up fluid pressure from the pump and air pressure from the compressor.
6. Lock the gun by flipping the trigger lock into lock position (see spray gun manual).
7. Unplug the unit.
8. For latex materials only, pour 100 ml water slowly on the top of the paint to prevent the paint from drying. For other materials, seal the material container keeping the return hose in the paint.
9. Wrap the spray gun assembly in a damp cloth and place it in a plastic bag. Seal the bag shut.
10. Place the unit in a safe place out of the sun for short-term storage.

Startup

1. Remove the gun from the plastic bag.
2. Stir the water into the paint for latex materials. Remove the cover from the material container and stir the paint for all other materials.
3. Perform the appropriate procedure in the "Painting" section of this manual for the type of spraying that will be performed.

7.2 Long-Term Storage



Do not allow paint to build up on the motor or the motor will overheat. Do not allow flammable solvents to come in contact with the motor or they could ignite.



If spraying with latex paint, use warm soapy water for cleaning. If using oil or alkyd-based paints, use mineral spirits or paint thinner.



Attention

Do not use mineral spirits or paint thinner on latex paint, or the mixture will turn into a jelly-like substance which is difficult to remove.

7.3 Clearing the Paint Hopper

1. Lock the gun by flipping the trigger lock into lock position (see spray gun manual).
2. Turn the pressure control knob counterclockwise to the minimum setting.
3. Turn the PRIME/SPRAY valve to PRIME.
4. Move the motor ON/OFF switch to OFF.
5. Direct the return tube into the original material container.
6. Move the motor ON/OFF switch to ON.
7. Turn the pressure control knob to 1/2 maximum pressure. This will draw the remaining material in the paint hopper through the pump, up the return tube, and into the material container.
8. Turn the pressure control knob counterclockwise to the minimum pressure setting.
9. Trigger the gun to relieve pressure and lock the gun.
10. Remove the spray tip and guard and place them into a container of water or appropriate solvent for the type of material with which you are painting.
11. Fill the paint hopper with water or an appropriate solvent for the type of material with which you are painting.
12. Direct the return tube into a waste bucket.
13. Increase the pressure to 1/2 the maximum pressure. Let the water or solvent circulate for 2-3 minutes to flush material out of the pump, the paint hopper, and the return tube.

7.4 Clearing the Optional Suction Set

1. Turn the pressure control knob counterclockwise to the minimum setting.
2. Turn the PRIME/SPRAY valve to PRIME.
3. Move the pump ON/OFF switch to the OFF position.
4. Move the compressor ON/OFF switch to the OFF position.
5. Wait a couple seconds, then trigger the gun into the material container to release built up fluid pressure from the pump and air pressure from the compressor.
6. Lock the gun by flipping the trigger lock into lock position (see spray gun manual).
7. Remove the suction hose from the material and hold it above a bucket of water or solvent. Leave the return hose in the material bucket.



Attention

Do not use mineral spirits or paint thinner on latex paint, the mixture will turn into a jelly-like substance that is difficult to remove.

8. Move the pump ON/OFF switch to the ON position.
9. Turn the pressure control knob to 1/2 maximum pressure. This will draw the remaining material in the suction hose through the pump, down the return hose and into the material bucket.
10. Turn the pressure control knob counterclockwise to the minimum setting.
11. Remove the spray tip and guard and place them into a container of the appropriate solvent.
12. Place the attached suction hose and return hose into the container of water or appropriate solvent.
13. Increase the pressure to 1/2 the maximum pressure. Let the water or solvent circulate for 2-3 minutes to flush paint out of the pump, the suction hose and the return hose.

7.5 Clearing the Spray Hose

1. Turn the pressure control knob counterclockwise to the minimum pressure setting.
2. Turn the PRIME/SPRAY valve to SPRAY.
3. Unlock the spray gun trigger.
4. Carefully trigger the gun with the spray tip removed against the inside of the material container.
5. Turn the pressure control knob slowly clockwise until material starts to flow into the container. As soon as the water or solvent starts to emerge from the spray gun, release the trigger.
6. Change to clean water or solvent and continue circulating for another 5 minutes to thoroughly clean the hose, pump and spray gun.
7. Turn the pressure control knob counterclockwise to its lowest setting.
8. Turn the PRIME/SPRAY valve to PRIME.
9. Trigger the gun into the water or solvent container to release built up fluid pressure from the pump.
10. Lock the gun by flipping the trigger lock into lock position (see spray gun manual).
11. Move the pump ON/OFF switch to the OFF position.

7.6 Final Cleanup

1. Remove the hopper assembly or suction set from the inlet valve.
2. Clean the threads of the inlet valve with a damp cloth.
3. Fill the inlet valve with water or with a light household oil.
4. Make sure that the PRIME/SPRAY valve is set to PRIME and that the pressure control knob is turned counterclockwise to its lowest pressure setting.
5. Turn on the pump by moving the pump ON/OFF switch to the ON position.
6. Increase the pressure by turning the pressure control knob clockwise 1/2 turn.
7. Turn the PRIME/SPRAY valve to SPRAY to distribute the oil.



Proper cleaning and oiling of the pump after use are the most important steps to perform to insure proper operation after storage.

8. Turn the pressure control knob counterclockwise to its lowest setting.
9. Turn the PRIME/SPRAY valve to PRIME.
10. Unlock and trigger the gun to remove any pressure that may still be in the hose.
11. Lock the gun by flipping the trigger lock into lock position (see spray gun manual).
12. Turn off the pump by moving the pump ON/OFF switch to the OFF position
13. Remove the material hose and air hose from the spray gun using two adjustable wrenches. Refer to the spray gun Owner's Manual for gun cleaning instructions.
14. Wipe the entire unit, hose, and gun with a damp cloth to remove accumulated paint.

8. Maintenance

Follow these procedures when encountering problems indicated in the troubleshooting section.

8.1 Removing and Cleaning the Inlet Valve

1. Perform the Pressure Relief Procedure, turn off and unplug the unit.
2. Remove the inlet valve assembly using a 27 millimeter socket or box end wrench.

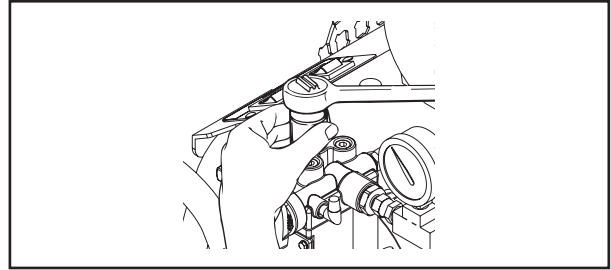

3. Test movement of the valve by pushing on it from the open end of the valve housing with a screwdriver or the eraser end of a pencil. It should move about 1.5 mm. If it does not move, it should be cleaned or replaced.

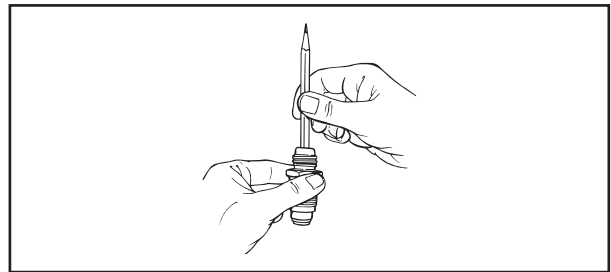

The inlet valve must be oiled after every job. This will reduce or eliminate priming problems the next time the unit is used as well as extend the life of the valve.

4. Thoroughly clean the valve assembly with water or the appropriate solvent. Use a small brush.
5. If the valve has been properly cleaned and water drips out of the bottom, the valve is worn and needs to be replaced. A properly seated valve filled with water and held vertically will not drip.
6. Install a new or cleaned valve in the pump block and then fill the valve with light oil or solvent.

8.2 Removing and Cleaning the Outlet Valve

It may be necessary to remove and clean the outlet valve or to replace parts inside the valve worn out through normal use.

1. Remove the outlet valve nut (a) with a wrench.
2. Remove and clean the ball stop (d) and small spring (c) inside the valve using a wire hook or tweezers. Replace the spring if it is broken or worn.



This spring is manufactured to a very specific tension. Do not stretch the spring. Do not put in an unauthorized substitute. See the paint pump assembly parts diagram for the proper replacement part number.

3. Remove the seat (f) and ball (e) assembly.
4. Clean all parts thoroughly. If the ball or seat show any sign of wear or damage, replace them with new parts. This carbide ball must seal tightly against its seat for the valve to function properly.
5. Cover all parts with a thin coat of light oil before reassembling.
6. Drop in the valve ball (e).
7. Insert the protector (f) and spring. Be sure that the O-ring (b) is positioned properly and that the tongue on the cap fits inside the spring.

8. Tighten the outlet valve nut (a) securely with an adjustable wrench. Do not over-tighten.

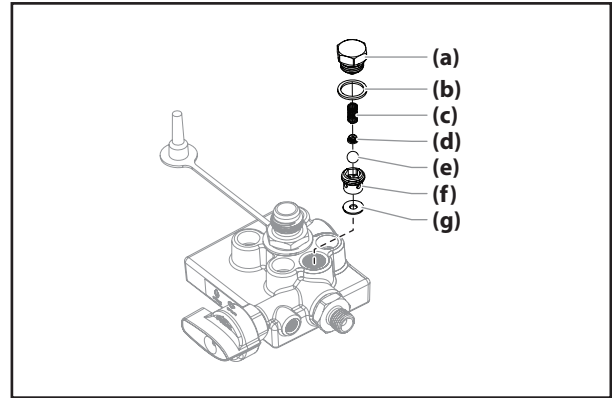

Wear on the ball is almost impossible to detect visually. To test for a worn outlet valve assembly, turn the pressure control knob clockwise to its highest setting and run water only through the pump for 10 to 15 minutes without triggering the gun.

If the valve is defective, the end cap will get very hot to the touch. If it is functioning properly, it will stay approximately the same temperature as the water running through it.

9. Electrical Schematic

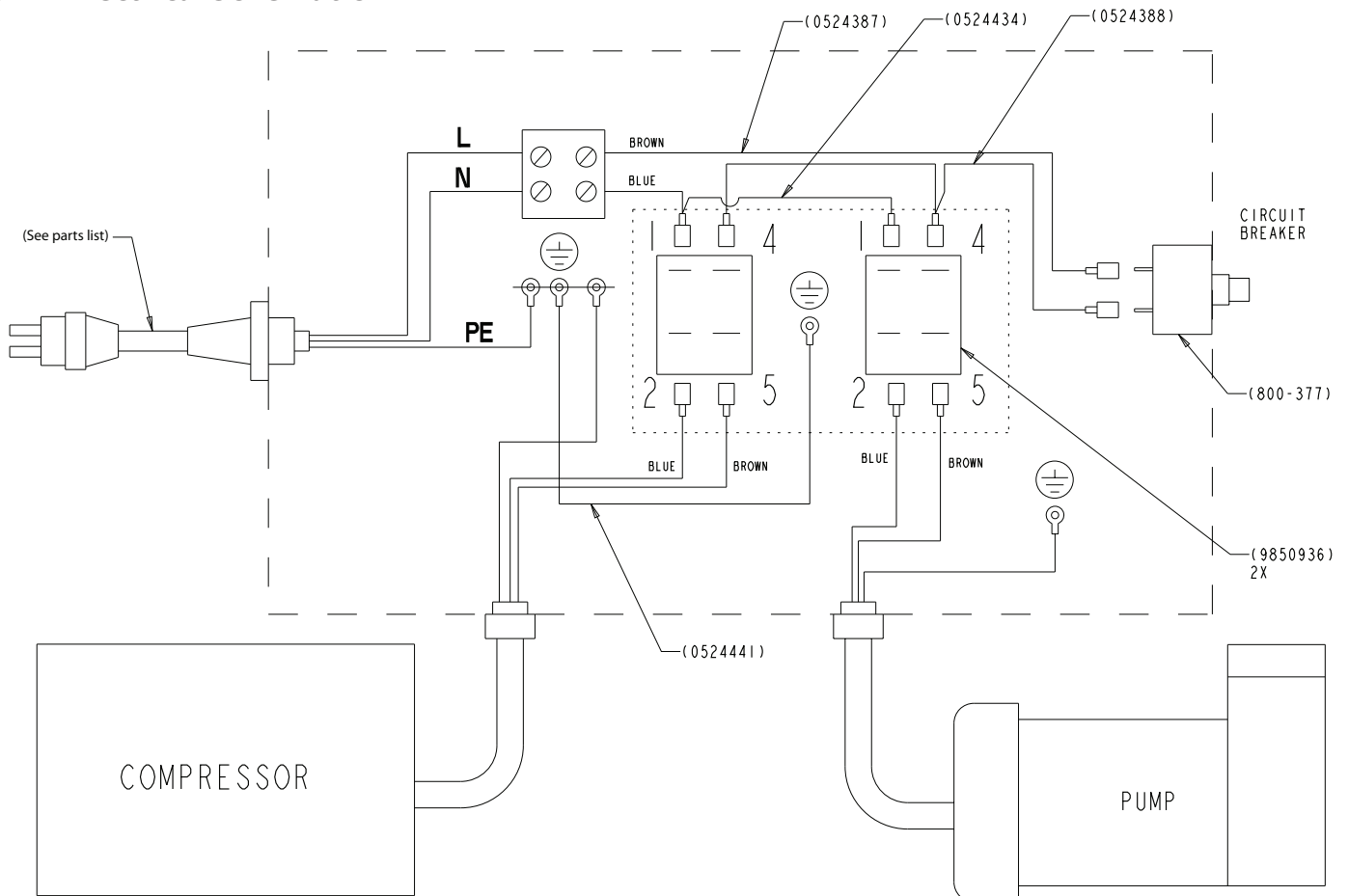

10. Troubleshooting

Problem	Cause	Solution
A. The unit does not start up.	<ol style="list-style-type: none"> The unit is not plugged in. The ON/OFF switch is set to OFF. A fuse is blown in the unit. Low or no voltage is coming from the wall plug. The unit was turned off while still under pressure. The extension cord is damaged or has too low a capacity. The thermal overload on the unit is tripped. There is a problem with the motor. 	<ol style="list-style-type: none"> Plug the unit in. Turn the ON/OFF switch to ON. Replace the blown fuse with the proper replacement. Properly test the power supply voltage. Turn the PRIME/SPRAY knob to PRIME. Replace the extension cord. Allow the motor to cool and move the unit to a cooler spot. Take the unit to a Wagner Authorized Service Center.
B. The pump starts up but does not draw in paint when the PRIME/SPRAY valve is set to PRIME.	<ol style="list-style-type: none"> The pump will not prime properly or has lost prime. The paint bucket is empty or the suction hose is not totally immersed in the paint. The suction filter is clogged. The suction hose is loose at the inlet valve. The inlet valve is stuck. The outlet valve is stuck. The PRIME/SPRAY valve is plugged. The inlet valve is worn or damaged. There is a problem with the diaphragm. The hydraulic oil level is low or empty. 	<ol style="list-style-type: none"> Try to prime the pump again. Immerse the suction hose in paint. Clean the suction set filter. Clean the tube connection and tighten it securely. Clean the inlet valve. Clean the outlet valve and replace any worn parts. Take the unit to a Wagner Authorized Service Center. Replace the inlet valve. Take the unit to a Wagner Authorized Service Center. Take the unit to a Wagner Authorized Service Center.
C. The pump draws up paint but the pressure drops when the gun is triggered.	<ol style="list-style-type: none"> The spray tip is worn. The suction set filter is clogged. The gun or spray tip filter is plugged. The paint is too heavy or coarse. The outlet valve assembly is dirty or worn. The inlet valve assembly is damaged or worn. 	<ol style="list-style-type: none"> Replace the spray tip with a new tip. Clean the suction set filter. Clean or replace the proper filter. Always keep extra filters on hand. Thin or strain the paint. Clean or replace the outlet valve assembly. Replace the inlet valve.
D. The paint pattern is tailing.	<ol style="list-style-type: none"> The fluid pressure is set too low. The air pressure is set too low. The gun, the tip, or the suction filter is plugged. The suction hose is loose at the inlet valve. The tip is worn. The paint is too thick. 	<ol style="list-style-type: none"> Increase the fluid pressure. Increase the air regulator setting. Clean the filters. Tighten the suction hose fitting. Replace the spray tip. Thin the paint.
E. The thermal overload tripped and shut off the pump.	<ol style="list-style-type: none"> The motor overheated. The extension cord is too long or is too small a gauge. Paint has built up on the motor. The motor was started while the unit was under pressure. The unit was sitting in the hot sun. 	<ol style="list-style-type: none"> Allow to cool for 30 minutes. Allow to cool for 30 minutes and replace the extension cord with a shorter extension or a thicker gauge cord. Clean the paint from the motor. Restart the unit in the PRIME mode. Move the unit out of the sun.
F. Compressor does not start.	<ol style="list-style-type: none"> The compressor ON/OFF switch is in the OFF position. Compressor ON/OFF switch is faulty. Compressor is faulty. Relief hole under air regulator is blocked. 	<ol style="list-style-type: none"> Move the compressor ON/OFF switch to the ON position. Take the unit to a Wagner Authorized Service Center. Take the unit to a Wagner Authorized Service Center. Clean out the relief hole.
G. Compressor starts but not enough air.	<ol style="list-style-type: none"> Air regulator setting is too low. Paint is too thick. Closed air valve on gun. Faulty pressure relief valve. 	<ol style="list-style-type: none"> Increase the air regulator setting. Thin the paint. Open the gun air valve. Refer to gun Owner's Manual. Install a new pressure relief valve.

Spare part diagram • Main assembly

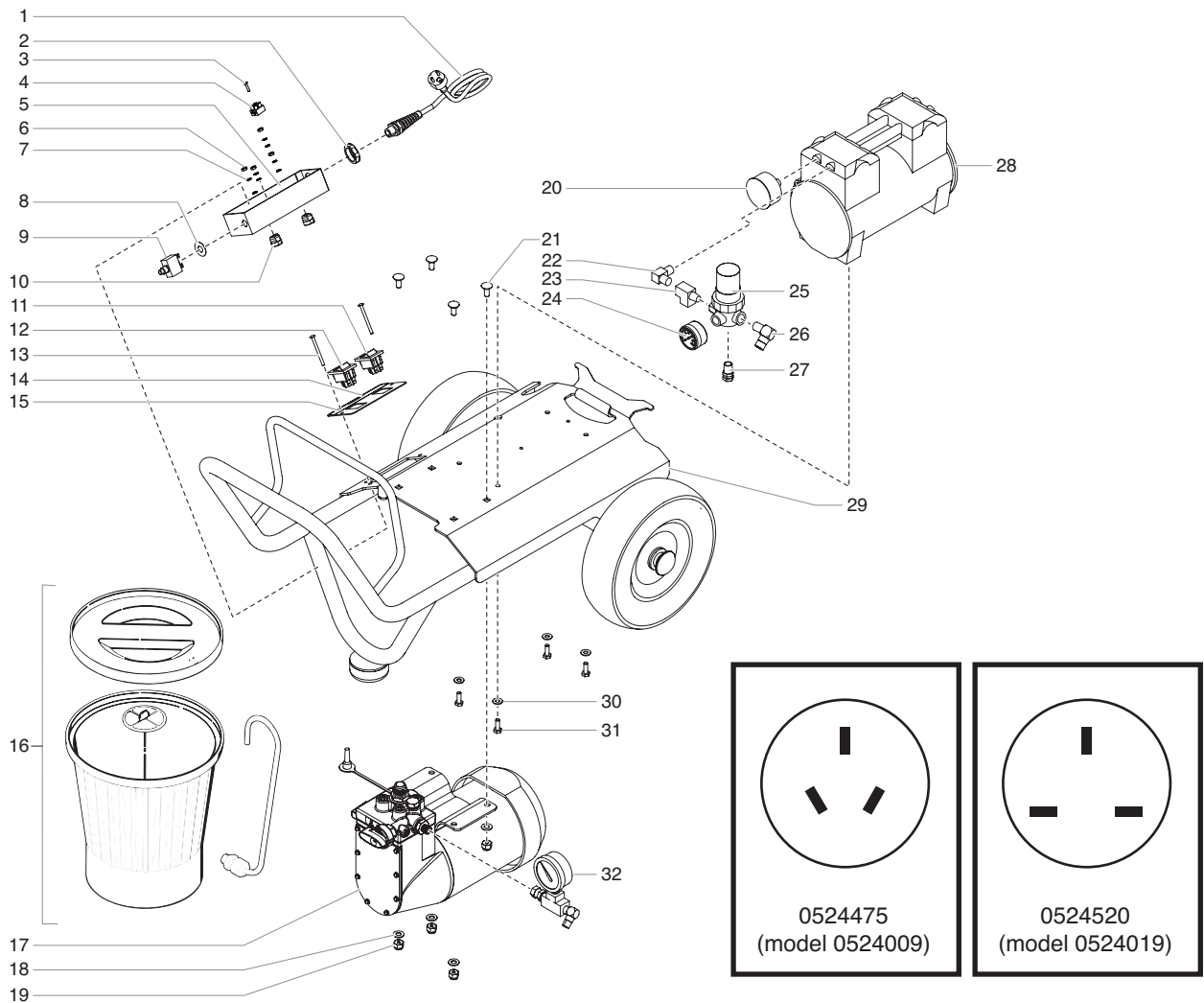

Item	Part #	Description
1	0524386	Power cord (model 0524009)
	0524520	Power cord (model 0524019)
2	0551980	Lock nut
3	0551495	Screw
4	9850577	Terminal block
5	0524447	Electrical housing
6	9810103	Nut (4)
7	9822106	Lock washer (8)
8	0507854	Label, "Press to Reset"
9	0508655	Circuit breaker, 8A
10	0276363	Strain relief (2)
11	9850936	Compressor ON/OFF switch
12	9850936	Pump ON/OFF switch
13	0551378	Screw (2)
14	0550016	Electrical cover
15	0524733	ON/OFF switch label
16	0524242	Hopper assembly
17	0550007	Diaphragm pump
18	0088372	Flat washer (4)

Item	Part #	Description
19	0295615	Lock nut (4)
20	0551376	Compressor filter
21	0551354	Carriage screw (4)
22	12440	Elbow, 90°
23	0524381	Tee, street
24	0261342	Gauge, air
25	0551360	Regulator, air
26	0524423	Elbow, 90°
27	0551361	Relief valve
28	0524247	Air compressor 230-240V, model 0524009 (includes item 20)
	0550009	Air compressor 230V, model 0524019 (includes item 20)
29	0508190	Cart assembly
30	0295693	Flat washer (4)
31	0295695	Hex screw (4)
32	0524221	Pressure gauge assembly
	9984595	Hose, AC, DN3/DN6, 7.5m (not pictured)
	0394152	Gun, AC 4600 Pro (not pictured)

Spare part diagram • Diaphragm pump (P/N 0550007)

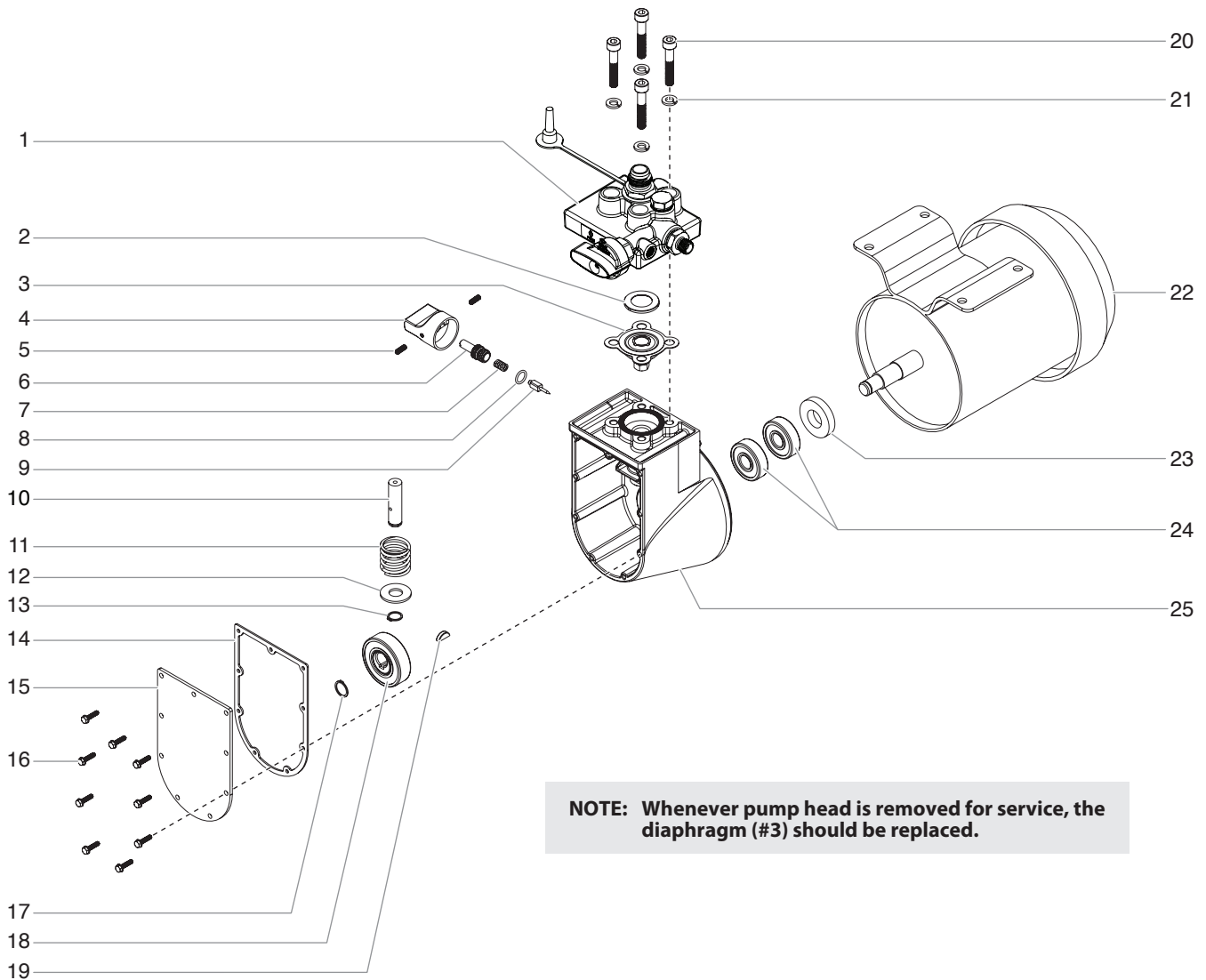

NOTE: Whenever pump head is removed for service, the diaphragm (#3) should be replaced.

Item	Part #	Description
1	0524227	Pump head (includes items #2-3)
2	0270494	Diaphragm ring
3	0270201	Diaphragm
4	0288775	Pressure control knob
5	9801109	Set screw (2)
6	0270529	Valve stem
7	0047373	Pressure regulating spring
8	0089518	O-ring
9	0089475	Pressure valve needle
10	0278345	Hydraulic piston
11	0005311	Piston spring
12	0270550	Piston washer
13	0089456	Retainer
14	0278359	Gasket

Item	Part #	Description
15	0278341	Hydraulic cover
16	9800049	Screw (9)
17	0047393	Retaining ring
18	0090031	Eccentric sleeve and bearing assembly
19	0089829	Shaft key
20	9900355	Socket screw (4)
21	9921601	Lock washer (4)
22	0524224A	Motor, 1/3HP (includes items 26 and 27)
23	0270524	Seal
24	0270490	Ball bearing (2)
25	0278238	Hydraulic housing assembly (includes items 23 and 24)
	0270462	Fan (not shown)
	0270612	Fan cover (not shown)

**Spare part diagram •
Cart assembly (P/N 0508190)**

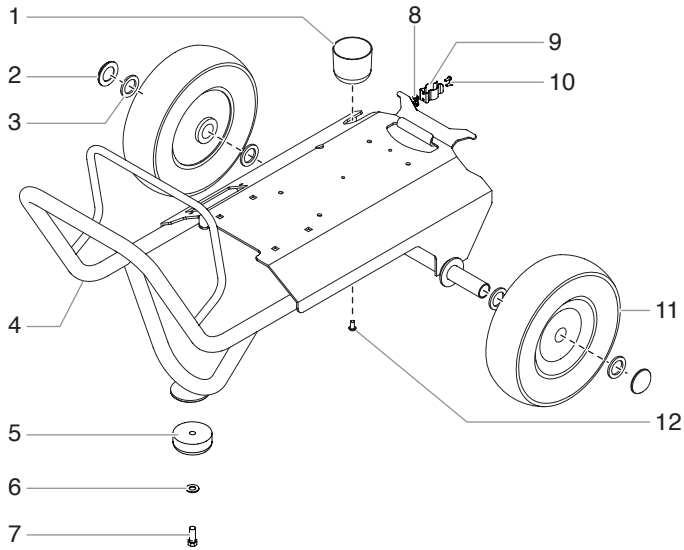

Item	Part #	Description
1	0508381	Paint cup
2	9890104	Cap (2)
3	0294534	Wheel spacer (10)
4	0508517	Cart weldment
5	0090005	Pad
6	9820305	Washer, flat
7	0090026	Screw, hex head
8	0551986	Nut with washer
9	0507937	Hose clip
10	9804916	Screw
11	0278373	Wheel (2)
12	9805230	Screw

**Spare part diagram •
Hopper assembly (P/N 0524242)**

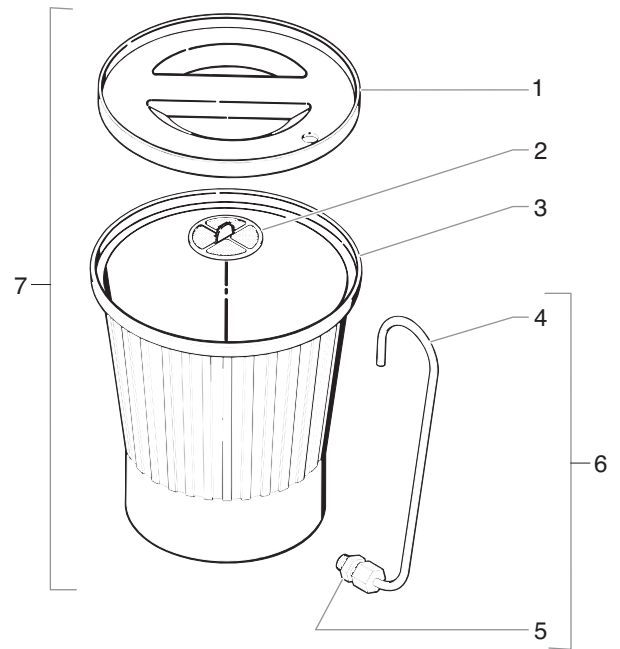

Item	Part #	Description
1	0279591	Cover, hopper
2	0089917	Filter screen, fine (shown)
	0088871	Filter screen, coarse
3	0524443	Hopper
4	0093865	Return tube
5	0403309	Fitting
6	0090560	Return tube assembly (includes items 4-5)
7	0524242	Hopper complete (includes items 1-6)

Spare part diagram •
Pump head assembly (P/N 0524227)

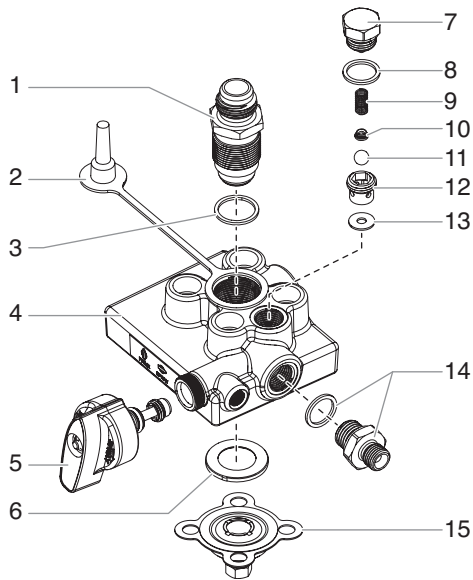

Item	Part #	Description
1	0278242	Inlet valve assembly
2	0278655	Inlet cap
3	0089482	Sealing washer, nylon
4	0270460	Paint pump
5	0555850	PRIME/SPRAY valve assembly
6	0270494	Ring diaphragm
7	0270487	End cap
8	9970103	Seal
9	0270499	Spring
10	0270497	Support, spring
11	0270491	Ball
12	0270197	Ball seat
13	0089494	Outlet seal
14	0288379	Fitting, outlet
15	0270201	Diaphragm

Spare part diagram •
Optional suction set (P/N 0508194A)

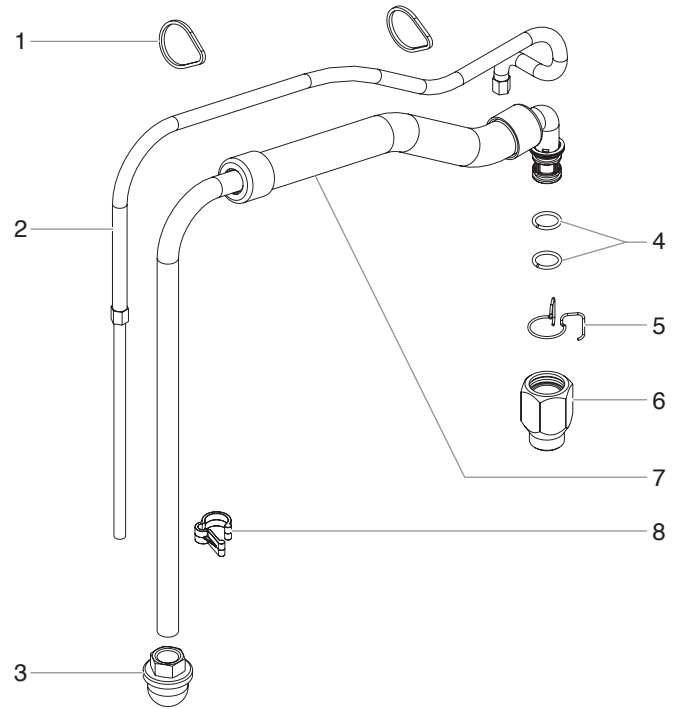

Item	Part #	Description
1	9850638	Tie wrap (2)
2	0508614	Return hose assembly
3	0295565	Inlet screen
4	9871105	O-ring (2)
5	9822526	Retaining clip
6	0551362	Nut
7	0551102	Suction hose assembly
8	0279459	Return hose clip
9	0551356	Elbow, 90°

- A** J. Wagner Ges.m.b.H.
Ottogasse 2/20
2333 Leopoldsdorf
Österreich
Tel. +43/ 2235 / 44 158
Telefax +43/ 2235 / 44 163
office@wagner-group.at
- B** WSB Finishing Equipment
Veilinglaan 56-58
1861 Wolvertem
Belgium
Tel. +32/2/269 46 75
Telefax +32/2/269 78 45
info@wagner-wsb.nl
- CH** Wagner International AG
Industriestrasse 22
9450 Altstätten
Schweiz
Tel. +41/71 / 7 57 22 11
Telefax +41/71 / 7 57 22 22
wagner@wagner-group.ch
- D** J. Wagner GmbH
Otto-Lilienthal-Straße 18
D-88677 Markdorf
Postfach 11 20
Deutschland
Tel. +49 / 75 44 / 505-1664
Telefax +49 / 75 44 / 505-1155
wagner@wagner-group.com
www.wagnergroup.com
- DK** Wagner Wagner
Scandinavia A/S
Helgeshøj Allé 28
2630 Taastrup
Denmark
Tel. +45/43/ 27 18 18
Telefax +45/43/ 43 05 28
wagner@wagner-group.dk
- E** Wagner Wagner Iberica S.A.
P.O. Box 132, Crta. N-340
08750 Molins de Rey
Barcelona / Espania
Tel. +34/93/6800028
Telefax +34/93/66800555
info@wagnerspain.com
- F** Wagner France
12 Avenue des Tropiques
Z.A. de Courtaboeuf,
91978 Les Ulis Cedex
France
Tel. 0 825 011 111
Telefax +33 (0) 69 81 72 57
division.batiment@wagner-france.fr
- CZ** Wagner, spol. s r.o.
Nedasovská str. 345
155 21 Praha 5 -Zlicín
Czechia
Tel. +42/ 2 / 579 50 412
Telefax +42/ 2 / 579 51 052
info@wagner.cz
- GB** Wagner Wagner (UK) Limited
The Coach House
2 Main Road
Middleton Cheney OX17 2ND
Great Britain
UK-Helpline 0844 335 0517
5 p per minute (landline)
- I** Wagner Colora
Via Fermi, 3
20875 Burago di Molgora (MB)
Italia
Tel. +39/ 039 / 625 021
Telefax +39/ 039 / 685 18 00
info@wagnercolora.com
- NL** WSB Finishing Equipment BV
De Heldinnenlaan 200
3543 MB Utrecht
Netherlands
Tel. +31/ 30/241 41 55
Telefax +31/ 30/241 17 87
info@wagner-wsb.nl
- S** Wagner Wagner
Scandinavia A/S
Helgeshøj Allé 28
2630 Taastrup
Denmark
Tel. +45/43/ 21 18 18
Telefax +45/43/ 43 05 28
wagner@wagner-group.dk

www.wagner-group.com

Important notes on product liability

As a result of an EC regulation being effective as from January 1, 1990, the manufacturer shall only be liable for his product if all parts come from him or are released by him, and if the devices are properly mounted and operated.

If the user applies outside accessories and spare parts, the manufacturer's liability can fully or partially be inapplicable; in extreme cases usage of the entire device can be prohibited by the competent authorities (employer's liability insurance association and factory inspectorate division).

Only the usage of original WAGNER accessories and spare parts guarantees that all safety regulations are observed.

3+2 years guarantee for professional finishing

Wagner professional guarantee
(Status 01.02.2009)

1. Scope of guarantee

All Wagner professional colour application devices (hereafter referred to as products) are carefully inspected, tested and are subject to strict checks under Wagner quality assurance. Wagner exclusively issues extended guarantees to commercial or professional users (hereafter referred to as "customer") who have purchased the product in an authorised specialist shop, and which relate to the products listed for that customer on the Internet under www.wagner-group.com/profi-guarantee.

The buyer's claim for liability for defects from the purchase agreement with the seller as well as statutory rights are not impaired by this guarantee.

We provide a guarantee in that we decide whether to replace or repair the product or individual parts, or take the device back and reimburse the purchase price. The costs for materials and working hours are our responsibility. Replaced products or parts become our property.

2. Guarantee period and registration

The guarantee period amounts to 36 months. For industrial use or equal wear, such as shift operations in particular, or in the event of rentals it amounts to 12 months.

Systems driven by petrol or air are also guaranteed for a 12 month period.

The guarantee period begins with the day of delivery by the authorised specialist shop. The date on the original purchase document is authoritative.

For all products bought in authorised specialist shops from 01.02.2009 the guarantee period is extended to 24 months providing the buyer of these devices registers in accordance with the following conditions within 4 weeks of the day of delivery by the authorised specialist shop.

Registration can be completed on the Internet under www.wagner-group.com/profi-guarantee. The guarantee certificate is valid as confirmation, as is the original purchase document that carries the date of the purchase. Registration is only possible if the buyer is in agreement with having the data being stored that is entered during registration.

When services are carried out under guarantee the guarantee period for the product is neither extended nor renewed.

Once the guarantee period has expired, claims made against the guarantee or from the guarantee can no longer be enforced.

3. Handling

If defects can be seen in the materials, processing or performance of the device during the guarantee period, guarantee claims must be made immediately, or at the latest within a period of 2 weeks.

The authorised specialist shop that delivered the device is entitled to accept guarantee claims. Guarantee claims may also be made to the service centres named in our operating instructions. The product has to be sent without charge or presented together with the original purchase document that includes details of the purchase date and the name of the product. In order to claim for an extension to the guarantee, the guarantee certificate must be included.

The costs as well as the risk of loss or damage to the product in transit or by the centre that accepts the guarantee claims or who delivers the repaired product, are the responsibility of the customer.

4. Exclusion of guarantee

Guarantee claims cannot be considered

- for parts that are subject to wear and tear due to use or other natural wear and tear, as well as defects in the product that are a result of natural wear and tear, or wear and tear due to use. This includes in particular cables, valves, packaging, jets, cylinders, pistons, means-carrying housing components, filters, pipes, seals, rotors, stators, etc. Damage due to wear and tear that is caused in particular by sanded coating materials, such as dispersions, plaster, putty, adhesives, glazes, quartz foundation.
- in the event of errors in devices that are due to non-compliance with the operating instructions, unsuitable or unprofessional use, incorrect assembly and/or commissioning by the buyer or by a third party, or utilisation other than is intended, abnormal ambient conditions, unsuitable coating materials, unsuitable operating conditions, operation with the incorrect mains voltage supply/frequency, over-operation or defective servicing or care and/or cleaning.
- for errors in the device that have been caused by using accessory parts, additional components or spare parts that are not original Wagner parts.
- for products to which modifications or additions have been carried out.
- for products where the serial number has been removed or is illegible
- for products to which attempts at repairs have been carried out by unauthorised persons.
- for products with slight deviations from the target properties, which are negligible with regard to the value and usability of the device.
- for products that have been partially or fully taken apart.

5. Additional regulations.

The above guarantees apply exclusively to products that have been bought by authorised specialist shops in the EU, CIS, Australia and are used within the reference country.

If the check shows that the case is not a guarantee case, repairs are carried out at the expense of the buyer.

The above regulations manage the legal relationship to us conclusively. Additional claims, in particular for damages and losses of any type, which occur as a result of the product or its use, are excluded from the product liability act except with regard to the area of application.

Claims for liability for defects to the specialist trader remain unaffected.

German law applies to this guarantee. The contractual language is German. In the event that the meaning of the German and a foreign text of this guarantee deviate from one another, the meaning of the German text has priority.

J. Wagner GmbH
Division Professional Finishing
Otto Lilienthal Strasse 18
88677 Markdorf
Federal Republic of Germany

Note on disposal:

In observance of the European Directive 2002/96/EC on waste electrical and electronic equipment and implementation in accordance with national law, this product is not to be disposed of together with household waste material but must be recycled in an environmentally friendly way!



Wagner or one of our dealers will take back your used Wagner waste electrical or electronic equipment and will dispose of it for you in an environmentally friendly way. Please ask your local Wagner service centre or dealer for details or contact us direct.



J. Wagner GmbH Otto Lilienthal-Str. 18 D-88677 Markdorf



CE Konformitätserklärung

CE Declaration of conformity

CE Déclaration de conformité

CE Konformiteitsverklaring

Hiermit erklären wir, daß die Bauart von
Airless Hochdruck-Spritzgerät

Herewith we declare that the supplied
version of
Airless high-pressure spraying unit

Par la présente, nous déclarons, que le type
de
Groupe de projection à haute pression

hiermede verklaren wij, dat de in de handel
gebrachte machine
Airless - hogedruk-spuitapparaat

WAGNER Finish 230 AC Compact

folgenden einschlägigen Bestimmungen
entspricht:

complies with the following provisions
applying to it:

correspond aux dispositions pertinentes
suivantes:

voldoet aan de eisen van de in het vervolg
genoemde bepalingen:

2006/42 EG, 2004/108 EG,

2006/42 EC, 2004/108 EC,

2006/42 CE, 2004/108 CE,

2006/42 EG, 2004/108 EG,

Angewendete harmonisierte Normen,
insbesondere:

Applied harmonized standards, in
particular:

Normes harmonisée utilisées, notamment:

Gebruikte geharmoniseerde normen, in
het bijzondere:

EN ISO 12100-1/-2, EN 1953 :1998+A1 :2009, EN 60204-1 :2007, EN 55014-1:2006, EN 55014-2 :1997, EN 61000-3-2 :2005, EN 61000-3-3 :1994

Angewendete nationale technische
Spezifikationen, insbesondere:

Applied national technical standards and
specifications, in particular:

Normes et spécifications techniques
nationales qui ont été utilisées,
notamment:

Gebruikte nationale technische normen en
specificaties, in het bijzondere:

BGR 500 /2/ Kapitel 2.29, 2.36

Markdorf, 16.05.2011

Location, Date

Signature

Vice President Product
Planning & Strategy

Hr. T. Jeltsch (Mr.)

Head of Development

Hr. J. Ulbrich (Mr.)

Dokumentationsverantwortlicher
Person responsible for documentation
Responsable de la documentation
Documentatieverantwoordelijke

(I)

CE Dichiarazione di conformità

Si dichiara che il modello
Impianto per la verniciatura a
spruzzo ad alta pressione Airless

(E)

CE Declaración de conformidad

por la presente, declaramos
que la
Airless equipo de pulverización
de alta presión

(DK)

CE Konformitetserklæring

Herved erklæres, at produkttypen
Airless - højtrykssprøjtapparat

(P)

CE Declaração de conformidade

Com a presente, declaramos que o
modelo da Aparelho de
pulverização de alta pressão Airless

(S)

CE Försäkrän

Härmed intygar vi att
lågtryckssprutpistol

è conforme alle seguenti disposizioni
pertinenti:

satisface las disposiciones
pertinentes siguientes:

er i overensstemmelse med følgende
bestemmelser:

está em conformidade com as
disposições pertinentes, a saber

är konstruerad enligt följande
gällande bestämmelser:

2006/42 CE, 2004/108 CE,

2006/42 CE, 2004/108 CE,

2006/42 EF, 2004/108 EF,

2006/42 CE, 2004/108 CE,

2006/42 EC, 2004/108 EC,

Norme armonizzate applicate, in
particolare

Normas armonizadas utilizadas,
particularmente:

Harmoniserede standarder, der blev
anvendt, i særdeleshed:

Normas harmonizadas utilizadas,
em particular:

Tillämpade harmoniserade
standarder, i synnerhet:

EN ISO 12100-1/-2, EN 1953 :1998+A1 :2009, EN 60204-1 :2007, EN 55014-1:2006, EN 55014-2 :1997, EN 61000-3-2 :2005, EN 61000-3-3 :1994

Norme e specificazioni tecniche
nazionali applicate, in particolare:

Normas y especificaciones
técnicas nacionales que se
utilizaron, particularmente:

Nationale standarder og tekniske
specifikationer, der blev anvendt, i
særdelshed:

Normas e especificações nacionais
utilizadas, em particular:

Tillämpade nationella, tekniska
specifikationer, i synnerhet:

BGR 500 /2/ Kapitel 2.29, 2.36

Markdorf, 29.12.2009
Location, Date

Vice President Product
Planning & Strategy

Hr. T. Jeltsch (Mr.)

Signature

Head of Development

Hr. J. Ulbrich (Mr.)

Responsabile della documentazione
Responsable de la documentación
Dokumentationsansvarlig
Responsável pela documentação
Documentationsansvarig