



Translation of the Original Operating Manual

Puma	Leopard	Jaguar
8-300 3-600	18-300 8-600	38-300

Version 07/2015

Icebreaker Piston Pumps Flow Rate 300 cm³ - 600 cm³

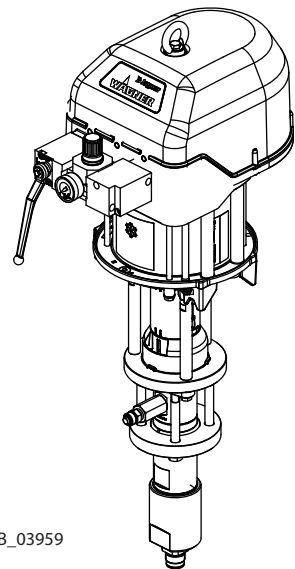
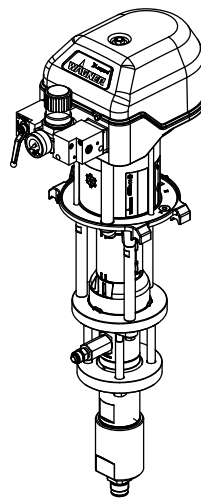
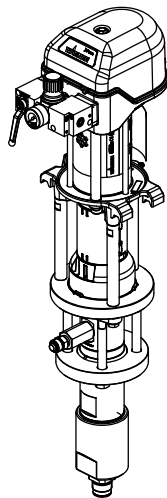

B_03959



II 2 G c IIBT3/T4 X

Table of Contents

1	ABOUT THESE INSTRUCTIONS	6
1.1	Preface	6
1.2	Warnings, Notices and Symbols in these Instructions	6
1.3	Languages	7
1.4	Abbreviations in the Text	7
1.5	Terminology for the Purpose of this Manual	8
2	CORRECT USE	9
2.1	Device Types	9
2.2	Type of Use	9
2.3	Field of Application	9
2.4	Safety Parameters	9
2.5	Processible Working Materials	10
2.6	Recommended Application Areas	11
2.7	Reasonably Foreseeable Misuse	11
2.8	Residual Risks	12
3	IDENTIFICATION	13
3.1	Explosion Protection Identification	13
3.2	Identification X	13
3.3	Type Plate	14
4	GENERAL SAFETY INSTRUCTIONS	15
4.1	Safety Instructions for the Operator	15
4.1.1	Electrical Equipment	15
4.1.2	Personnel Qualifications	15
4.1.3	Safe Work Environment	15
4.2	Safety Instructions for Staff	16
4.2.1	Safe Handling of WAGNER Spray Devices	16
4.2.2	Grounding the Device	17
4.2.3	Product Hoses	17
4.2.4	Cleaning and Flushing	18
4.2.5	Handling Hazardous Liquids, Varnishes and Paints	19
4.2.6	Touching Hot Surfaces	19
5	DESCRIPTION	20
5.1	Components	20
5.2	Mode of Operation	20
5.3	Protective and Monitoring Equipment	21
5.4	Scope of Delivery	21
5.5	Data	22
5.5.1	Materials of Paint-wetted Parts	22
5.5.2	Recommended Packings	22
5.5.3	Technical Data	22
5.5.3.1	Technical Data	23
5.5.3.2	Measurements and Connections	24
5.5.4	Performance Diagrams	26
5.6	Pressure Regulator Unit	28
5.7	Product Filter and Return Flow	28
5.7.1	High-Pressure Filter (Option)	29

Table of Contents

5.8	Stroke Count (Option)	30
5.9	Feed Pump (Option)	31
6	ASSEMBLY AND COMMISSIONING	32
6.1	Training Assembly/Commissioning Staff	32
6.2	Storage and Installation Conditions	32
6.3	Transportation	32
6.4	Assembling the Pump	33
6.4.1	Ventilation of the Spray Booth	33
6.5	Grounding	34
6.6	Commissioning	35
7	OPERATION	36
7.1	Training the Operating Staff	36
7.2	Safety Instructions	36
7.2.1	General Rules for Making Adjustments to the Spray Gun	37
7.3	Emergency Stop	37
7.4	Spraying	38
7.5	Pressure Relief/Work Interruption	38
7.6	Basic Flushing	39
7.6.1	Filling with Working Material	39
8	CLEANING AND MAINTENANCE	40
8.1	Cleaning	40
8.1.1	Cleaning Staff	40
8.1.2	Safety Instructions	40
8.1.3	Decommissioning and Cleaning	41
8.1.4	Long-term Storage	41
8.2	Maintenance	42
8.2.1	Maintenance Staff	42
8.2.2	Safety Instructions	42
8.2.3	Regular Maintenance Work	43
8.2.4	Filling Separating Agent	43
8.2.5	Emptying the Pump	44
8.2.6	Filling the Empty Pump	45
8.2.7	High-pressure Filter 270 bar and 530 bar	46
8.2.8	Product Hoses, Tubes and Couplings	47
9	TROUBLESHOOTING AND RECTIFICATION	48
10	REPAIR	49
10.1	Repair Personnel	49
10.2	Mounting Materials	49
11	DISPOSAL	49
12	ACCESSORIES	50
12.1	Accessories for Product Outlet	50
12.2	Accessories for Product Inlet	52
12.3	Trolley, Rack and Wall Bracket Accessories	54
13	SPARE PARTS	57
13.1	How Can Spare Parts Be Ordered?	57

Table of Contents

13.2	Overview of the Components	58
13.3	Air Motors	60
13.3.1	Puma and Leopard Air Motors	60
13.3.2	Puma Air Motor Regulator	63
13.3.3	Leopard Air Motor Regulator	64
13.3.4	Jaguar Air Motor	65
13.3.5	Jaguar Air Motor Regulator	69
13.4.	Connection sets	70
13.5	Fluid Sections	71
13.5.1	Fluid Section 300 cm ³	71
13.5.2	Fluid Section 600 cm ³	74
13.6	High-pressure Filter 270 bar; 3916 psi	78
13.7	High-pressure Filter (up to 530 bar; 7687 psi)	80
13.8	Trolley	82
13.9	„Heavy Duty“ Trolley	83
14	WARRANTY AND CONFORMITY DECLARATIONS	84
14.1	Important Notes Regarding Product Liability	84
14.2	Warranty Claim	84
14.3	CE Declaration of Conformity	85
14.4	Notes on National Regulations and Guidelines	85

1 ABOUT THESE INSTRUCTIONS

1.1 PREFACE

The operating manual contains information about safely operating, maintaining, cleaning and repairing the device.

The operating manual is part of the device and must be available to operating and service staff.

The device may only be operated by trained staff and in compliance with this operating manual. Operating and service personnel should be instructed according to the safety instructions.

This equipment can be dangerous if it is not operated according to the instructions in this operating manual.

1.2 WARNINGS, NOTICES AND SYMBOLS IN THESE INSTRUCTIONS

Warning instructions in this operating manual highlight particular dangers to users and to the device and state measures for avoiding the hazard. These warning instructions fall into the following categories:

Danger - immediate risk of danger.
Non-observance will result in death or serious injury.

	⚠ DANGER
	This notice warns you of a hazard! Possible consequences of not observing the warning instructions. The signal word indicates the hazard level. → The measures for preventing the danger and its consequences.

Warning - possible imminent danger.
Non-observance may result in death or serious injury.

	⚠ WARNING
	This notice warns you of a hazard! Possible consequences of not observing the warning instructions. The signal word indicates the hazard level. → The measures for preventing the danger and its consequences.

Caution - a possibly hazardous situation.
Non-observance may result in minor injury.

	⚠ CAUTION
	This notice warns you of a hazard! Possible consequences of not observing the warning instructions. The signal word indicates the hazard level. → The measures for preventing the danger and its consequences.

Notice - a possibly hazardous situation.
Non-observance may result in damage to property.

NOTICE
This notice warns you of a hazard! Possible consequences of not observing the warning instructions. The signal word indicates the hazard level. → The measures for preventing the danger and its consequences.

Note - provides information about particular characteristics and how to proceed.

1.3 LANGUAGES

The operating manual is available in the following languages:

Language	Order No.	Language	Order No.
German	2333547	English	2333548
French	2333549	Italian	2333550
Spanish	2333551		

The corresponding service manuals are available under the following order number:

Language	Order No.	Language	Order No.
German	2336589	English	2336590

Additional languages on request or at: www.wagner-group.com

1.4 ABBREVIATIONS IN THE TEXT

Stk	Number of pieces
Pos	Position
K	Marking in the spare parts lists
Order No.	Order number
DH	Double stroke
DN	Nominal diameter
PN	Nominal pressure
2K	Two components

Materials

SSt	Stainless steel
PE	Polyethylene
UHMWPE	Ultra-high molecular weight polyethylene
PTFE	Polytetrafluorethylene
TG	PTFE with graphite
T	PTFE
L	Leather

1.5 TERMINOLOGY FOR THE PURPOSE OF THIS MANUAL

Cleaning	Manual cleaning of devices and device parts with cleaning agent
Flushing	Internal flushing of paint-wetted parts with flushing agent
Staff qualifications	
Trained person	Is instructed in the tasks assigned to him/her, the potential risks associated with improper behavior as well as the necessary protective devices and measures.
Electrically trained person	Is instructed by an electrician about the tasks assigned to him/her, the potential risks associated with improper behavior as well as the necessary protective devices and measures.
Electrician	Can assess the work assigned to him/her and detect possible hazards based on his/her technical training, knowledge and experience in relevant provisions.
Skilled person In the context of TRBS 1203 (2010 / Revision 2012)	A person who, based on his/her technical training, experience and recent vocational experience, has sufficient technical knowledge and is familiar with the relevant and generally accepted rules of technology so that he/she can inspect and assess the status of devices and coating systems based on workplace safety. → Additional requirements for skilled persons are given in the TRBS 1203 (2010/Revision 2012): Expert knowledge in the areas of protection against excessive pressure, electrical hazards, and explosion protection (where applicable).

2 CORRECT USE

2.1 DEVICE TYPES

Pneumatic pump with spraypack:

Puma	Leopard	Jaguar
8-30	18-300	38-300
3-600	8-600	

2.2 TYPE OF USE

The device is suitable for processing liquid materials like paints and lacquers in accordance with the classification into explosion classes IIA or IIB.

2.3 FIELD OF APPLICATION

The pneumatic pump can be used in potentially explosive areas (Zone 1). → See Chapter 3.



2.4 SAFETY PARAMETERS

WAGNER accepts no liability for any damage arising from incorrect use.

- Use the device only to work with the products recommended by WAGNER.
- Only operate the device as a whole.
- Do not deactivate safety fixtures.
- Use only WAGNER original spare parts and accessories.



The pneumatic pump may only be operated under the following conditions:

- The operating staff must be trained on the basis of this operating manual.
- The safety regulations listed in this operating manual must be observed.
- The operating, maintenance and repair information in this operating manual must be observed.
- The statutory requirements and accident prevention regulation standards in the country of use must be observed.

2.5 PROCESSIBLE WORKING MATERIALS

Application	PUMA 8-300	PUMA 3-600	LEOPARD 18-300	LEOPARD 8-600	JAGUAR 38-300
Water-dilutable products	↗	↗	↗	↗	↗
Solvent-based lacquers and paints	↗	↗	↗	↗	↗
Primers	↗	↗	↗	↗	↗
Epoxy and polyurethane paints and varnish	↗	↗	↗	↗	↗
Liquid plastics	↗	⇒	↗	⇒	↗
Wax-based underside protection	↗	⇒	↗	⇒	↗
Oils	↗	↗	↗	↗	↗
Emulsions	↗	↗	↗	↗	↗
Filled paints	⇒	⇒	⇒	⇒	↗
Chemically aggressive products that attack carbide seats	↘	↘	↘	↘	↘

Legend

↗ recommended

⇒ limited suitability

↘ less suitable

NOTICE**Abrasive working materials and pigments!**

Greater wear of parts carrying the product.

- Do not use any grainy and abrasive working materials with large, sharp-edged pigments.
- Use the application-related model (flow rate/cycle, material packaging, valve seat, etc.), as specified in Chapter 5.5.
- Check if the fluids and solvents used are compatible with the pump construction materials as indicated in Chapter 5.5.1.

Wear caused by abrasive working materials is not covered by the warranty.

2.6 RECOMMENDED APPLICATION AREAS

Application	PUMA 8-300	PUMA 3-600	LEOPARD 18-300	LEOPARD 8-600	JAGUAR 38-300
Furniture industry	↗	↗	↗	↗	↗
Kitchen manufacturers	↗	↗	↗	↗	↗
Wood industry	↗	↗	↗	↗	↗
Window factories	↗	⇒	↗	⇒	↗
Steel-processing industry	↗	⇒	↗	⇒	↗
Construction of vehicles	↗	↗	↗	↗	↘
Automotive industry	↗	↗	↗	↗	↘
Corrosion protection operations	↗	↘	↗	↘	⇒
Original equipment manufacturer	↗	↗	↗	↗	↗
Contract coating companies	↗	↘	↗	↘	↘
Mechanical engineering	↗	⇒	↗	⇒	⇒
Plastics industry	↗	↗	↗	↗	↘
Municipal enterprises	↗	↘	↗	↘	↘

Legend

↗ recommended

⇒ limited suitability

↘ less suitable

2.7 REASONABLY FORESEEABLE MISUSE

The forms of misuse listed below may result in physical injury or property damage:

- coating work pieces which are not grounded;
- unauthorized conversions or modifications to the pneumatic pump;
- processing dry or similar coating products, e.g., powder;
- using defective components, spare parts or accessories other than those described in the "Accessories" chapter of this operating manual;
- continuing work with a defective or kinked product hose;
- working with incorrectly set values;
- processing food.

2.8 RESIDUAL RISKS

Residual risks are risks which cannot be ruled out even in the event of correct use.

If necessary, warning and prohibition signs at the relevant points of risk indicate residual risks.

Residual risk	Source	Consequences	Specific measures	Lifecycle phase
Skin contact with lacquers and cleaning agents	Handling of lacquers and cleaning agents	Skin irritation, allergies	Use personal safety equipment. Observe safety data sheets	Operation, maintenance, disassembly
Lacquer in air outside the defined working area	Lacquering outside the defined working area	Inhalation of substances hazardous to health	Observe work and operation instructions. Use personal safety equipment	Operation, maintenance

3 IDENTIFICATION

3.1 EXPLOSION PROTECTION IDENTIFICATION

As defined in Directive 94/9/EC (ATEX 95), the device is suitable for use in potentially explosive areas.

CE  II 2 G c IIB T3/T4 X

CE CE mark (European Communities)

 Explosion-proof equipment

II Device class II (not mining)

2 Category 2 device (suitable for zone 1)

G Ex-atmosphere gas

c Constructional security

IIB Device class (Gas) IIB

T3 Temperature class T3: maximum surface temperature 200 °C; 392 °F

T4 Temperature class T4: maximum surface temperature 135 °C; 275 °F

X Special instructions exist for safe operation. → See the following Chapter "Identification X".



3.2 IDENTIFICATION X

Maximum surface temperature

The maximum surface temperature T3 of the piston pump can be reached if it runs dry.

→ Ensure that the piston pump is filled with sufficient working or flushing agent.

→ Ensure that the separating agent tank is filled with sufficient separating agent.

Temperature class T3: No dry running protection.

Temperature class T4: With dry running protection.

Ignition temperature

→ Ensure that the ignition temperature of the surrounding gases (pumping product, cleaning agents) is higher than the maximum permitted surface temperature of the device.

Ambient temperature

→ The permissible ambient temperature is: +5 °C to +50 °C; +41 °F to +122 °F.

Medium supporting atomizing

→ To atomize the product, use only weakly oxidizing gases, e.g., air.

Safe handling of WAGNER spray devices

Mechanical sparks can form if the device comes into contact with metal.

In an explosive atmosphere:

- Do not knock or push the device against steel or rusty iron.
- Do not drop the device.
- Use only tools that are made of a permitted material.

**Surface spraying, electrostatics**

- Do not spray device parts using electrostatic equipment.

**Cleaning**

If there are deposits on the surfaces, the device may form electrostatic charges. Flames or sparks can form during discharge.

- Remove deposits from the surfaces to maintain conductivity.
- Use only a damp cloth to clean the device.

**National regulations**

- Ensure that the national explosion prevention rules and regulations are observed when setting up the device.

Air in the pump fluid

Flammable gas mixtures can form if air reaches the pump fluid.

- Prevent the pump from taking in air and running dry.
- If air has been taken in, fix the leak. Then, fill slowly and in a controlled manner until the air has escaped.

Air in the pumped fluid can be caused by damaged packings.



- Avoid operating the pump with damaged packing.
- Ensure that the separating fluid tank is filled with sufficient separating fluid.
- Periodically check that the pump is working smoothly, paying special attention to the presence of air in the pumped fluid.

Filling and emptying

Flammable gas mixtures can form in the fluid section or product hoses if the pump must be emptied for maintenance.

- Empty and fill the device slowly and in a controlled manner.
- Avoid potentially explosive atmosphere in the surroundings.

3.3 TYPE PLATE

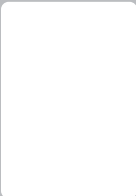
1	 <small>J. WAGNER AG CH-9450 ALTSTÄTTEN MADE IN SWITZERLAND</small>	  <small>II 2 G c IIB T3/T4 X</small>	<p>1 Manufacturer and CE Identification</p> <p>2 Pump type</p> <p>3 Maximum product pressure</p> <p>4 Pump ratio</p> <p>5 Flow rate per double stroke</p> <p>6 Maximum air inlet pressure</p> <p>7 Maximum product temperature</p> <p>8 Model year - serial number</p> <p>9 Read operating manual before use!</p>
2	Pumpentyp / Pump type		
3	Max. Materialdruck / Fluid pressure		
4	Übersetzungsverhältnis / Ratio		
5	Fördermenge DH / Delivery DS		
6	Max. Luftdruck / Air pressure		
7	Max. Temp. Material / Fluid		
8	Baujahr - Serie Nr. / Year of manufacture - Serial No.		
9	Vor Gebrauch Betriebsanleitung beachten / Check manual before use!		

4 GENERAL SAFETY INSTRUCTIONS

4.1 SAFETY INSTRUCTIONS FOR THE OPERATOR

- Keep this operating manual at hand near the device at all times.
- Always follow local regulations concerning occupational safety and accident prevention.



4.1.1 ELECTRICAL EQUIPMENT

Electrical devices and equipment

- To be provided in accordance with the local safety requirements with regard to the operating mode and ambient influences.
- May only be maintained by skilled electricians or under their supervision. With open housings, there is a danger from line voltage.
- Must be operated in accordance with the safety regulations and electrotechnical regulations.
- Must be repaired immediately in the event of problems.
- Must be decommissioned if they pose a hazard or are damaged.
- Must be de-energized before work is commenced on active parts. Inform staff about planned work. Observe electrical safety regulations.
- Ground all devices to a common grounding point.
- Only operate the device with a properly installed socket with a protective ground wire connection.
- Keep liquids away from electrical devices.



4.1.2 PERSONNEL QUALIFICATIONS

- Ensure that the device is only operated, maintained and repaired by trained persons.

4.1.3 SAFE WORK ENVIRONMENT

- Ensure that the floor in the working area is static dissipative in accordance with EN 61340-4-1 (resistance must not exceed 100 megohms).
- Paint mist extraction systems/ventilation systems must be fitted on site according to local regulations.
- Ensure that product / air hoses adapted to the working pressure are used.
- Ensure that personal protective equipment is available and is used.
- Ensure that all persons within the working area wear static dissipative shoes. Footwear must comply with EN 20344. The measured insulation resistance must not exceed 100 megohms.

- Ensure that during spraying, persons wear static dissipative gloves. The grounding takes place via the spray gun handle.
- Protective clothing, including gloves, must comply with EN 1149-5. The measured insulation resistance must not exceed 100 megohms.
- Ensure that there are no ignition sources such as naked flames, sparks, glowing wires, or hot surfaces in the vicinity. Do not smoke.
- Ensure that the pipe joints, hoses, equipment parts and connections are permanently, technically leak-proof:
 - Periodic preventative maintenance and service (replacing hoses, checking tightness strength and connections, etc.)
 - Regular monitoring of leaks and defects via visual inspection and odor testing, e.g., daily before commissioning, at the end of work or weekly.
- In the event of defects, immediately bring the device or system to a stop and arrange to have repairs carried out immediately.

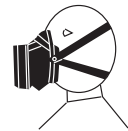

Grounding

- Make sure that the ground and potential equalization of all system parts are performed reliably and continuously and can withstand the expected stress (e.g., mechanical stress, corrosion).

4.2 SAFETY INSTRUCTIONS FOR STAFF

- Always follow the information in this manual, particularly the general safety instructions and the warning instructions.
- Always follow local regulations concerning occupational safety and accident prevention.
- In electrostatics application: Anyone fitted with a pacemaker must not enter the high-voltage area!



4.2.1 SAFE HANDLING OF WAGNER SPRAY DEVICES

The spray jet is under pressure and can cause dangerous injuries.

Avoid injection of paint or flushing agents:

- Never point the spray gun at people.
- Never reach into the spray jet.
- Before all work on the device, in the event of work interruptions and functional faults:
 - Relieve pressure from spray guns and devices.
 - Secure spray guns against actuation.
 - Switch off the energy/compressed air supply.
 - Disconnect the control unit from the mains.
 - In the event of functional faults, remedy the fault as described in the "Troubleshooting" chapter.



- If needed, the liquid ejection devices must be checked by experts (e.g., WAGNER service technician) at least every 12 months for their work-safe condition in accordance with DGUV regulation 100-500.
 - For shut down devices, the examination can be suspended until the next start-up.
- Carry out the work steps as described in the "Pressure Relief" chapter:
 - If pressure relief is required.
 - If the spraying work is interrupted or stopped.
 - Before the device is cleaned on the outside, checked or serviced.
 - Before the spray nozzle is installed or cleaned.

In the event of skin injuries caused by paint or flushing agents:

- Note the paint or flushing agent that you have been using.
- Consult a doctor immediately.

Avoid risk of injury from recoil forces:

- Ensure that you have firm footing when operating the spray gun.
- Only hold the spray gun briefly in a position.

4.2.2 GROUNDING THE DEVICE

Friction, flowing liquids and air or electrostatic coating processes create charges. Flames or sparks can form during discharge. Grounding prevents electrostatic charging.

- Ensure that the device is grounded. → See chapter "Grounding".
- Ground the work pieces to be coated.
- Ensure that all persons inside the working area are grounded, e.g., that they are wearing static dissipative shoes.
- Wear static dissipative gloves when spraying. The grounding takes place via the spray gun handle.
- The spray substance supply (spray substance tank, pump, etc.) must be grounded.

**4.2.3 PRODUCT HOSES**

- Ensure that the hose material is chemically resistant to the sprayed products and the flushing agents used.
- Ensure that the product hose is suitable for the pressure generated.
- Ensure that the following information can be seen on the high-pressure hose:
 - Manufacturer
 - Permissible operating pressure
 - Date of manufacture



- Make sure that the hoses are laid only in suitable places. Do not lay hoses:
 - in high-traffic areas,
 - on sharp edges,
 - on moving parts or
 - on hot surfaces.
- Ensure that the hoses are never run over by vehicles (e.g., fork lifts), or that the hoses are never put under pressure from the outside in any other way.
- Ensure that the hoses are never kinked. Observe maximum bending radii.
- Make sure that the hoses are never used to pull or move the equipment.
- The electrical resistance of the product hose, measured at both valves, must be less than 1 megohm.
- Suction hoses may not be subjected to pressure.

Several liquids have a high expansion coefficient. In some cases their volume can rise with consequent damage to pipes, fittings, etc. and cause fluid leakage.

When the pump sucks liquid from a closed tank, ensure that air or a suitable gas can enter the tank. Thus a negative pressure is avoided. The vacuum could implode the tank (squeeze) and can cause it to break. The tank would leak and the liquid would flow out. The pressure created by the pump is a multiplication of the inlet air pressure.

4.2.4 CLEANING AND FLUSHING

- Relieve the pressure from the device.
- De-energize the device electrically.
- Preference should be given to non-flammable cleaning and flushing agents.
- When carrying out cleaning work with flammable cleaning agents, make sure that all equipment and resources (e.g., collection tank, funnel, transport cart) are conductive or static dissipative and grounded.
- Observe the specifications of the paint manufacturer.
- Ensure that the flash point of the cleaning agent is at least 15 K above the ambient temperature or that cleaning is undertaken at a cleaning station with technical ventilation.
- Take measures for workplace safety (see Chapter 4.1.3).
- When commissioning or emptying the device, please note that an explosive mixture may temporarily exist inside the lines and components of equipment:
 - depending on the coating product used,
 - depending on the flushing agent (solvent) used,explosive mixture inside the lines and items of equipment.



- Only electrically conductive tanks may be used for cleaning and flushing agents.
- The tanks must be grounded.

An explosive gas/air mixture forms in closed tanks.

- Never spray into a closed tank when using solvents for flushing.

External cleaning

When cleaning the exterior of the device or its parts, also observe the following:

- Disconnect the pneumatic supply line.
- Use only moistened cloths and brushes. Never use abrasive agents or hard objects and never spray cleaning agents with a gun. Cleaning the device must not damage it in any way.
- Ensure that no electric component is cleaned with or immersed into solvent.

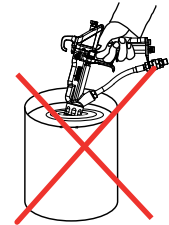

4.2.5 HANDLING HAZARDOUS LIQUIDS, VARNISHES AND PAINTS

- When preparing or working with lacquer and when cleaning the device, follow the working instructions of the manufacturer of the lacquers, solvents and cleaning agents being used.
- Take the specified protective measures. In particular, use personal protective equipment: safety goggles, protective clothing and gloves, as well as respiratory protection and skin protection cream if necessary.
- Use a mask or breathing apparatus if necessary.
- For sufficient health and environmental safety: Operate the device in a spray booth or on a spraying wall with the ventilation (extraction) switched on.
- Wear suitable protective clothing when working with hot products.



4.2.6 TOUCHING HOT SURFACES

- Only touch hot surfaces if you are wearing protective gloves.
- When operating the device with a coating product with a temperature of > 43 °C; 109 °F: identify the unit with a warning label that says "Warning - Hot Surface".
 - Instruction label Order no. 9998910
 - Protection label Order no. 9998911

Note: Order the two stickers together.



5 DESCRIPTION

5.1 COMPONENTS

- 1 Control housing with integrated silencer
- 2 Air pressure regulator
- 3 Ball valve
- 4 Air motor
- 5 Compressed air Inlet
- 6 Mounting flange
- 7 Separating agent cup
8. Product outlet
- 9 Fluid section
- 10 Product inlet
- 11 Grounding connection

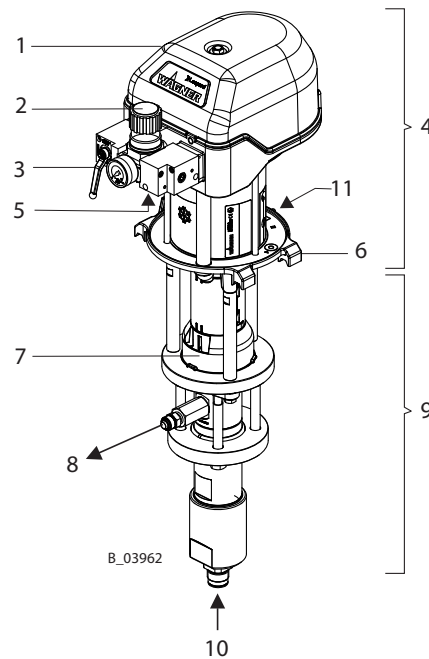

5.2 MODE OF OPERATION

The piston pump is driven with compressed air (2). This compressed air moves the air piston up and down in the air motor (4) and it also moves the associated pump piston up and down in the fluid section (9).

In the control housing (1), the air pressure is redirected at the end of each stroke with the help of the reversing valve. The working material is sucked up during the upwards stroke and is continuously conveyed towards the product outlet (8) in both stroke directions.

Air motor (4)

The air motor with its pneumatic reverse (1) does not require pneumatic oil.

The compressed air is fed to the motor via the air regulator (2) and the ball valve (3).

Fluid section (9)



The fluid section has been designed as a piston pump with exchangeable ball valves. The hard chrome-plated pump piston runs in two fixed packings which are self-adjusting by means of a pressure spring, thus resulting in a long service life.

Between the air motor and the fluid section there is a separating agent cup (7) for separating the separating agent.

5.3 PROTECTIVE AND MONITORING EQUIPMENT

Safety valve

The air motor is fitted with a safety valve. The safety valve has been set and sealed at the factory. In case of pressures over and above the permissible operating pressure, the valve, which is held with a spring, automatically opens and releases the excess pressure.

	 WARNING
	<p>Overpressure! Risk of injury from bursting components.</p> <p>→ Never change the safety valve setting.</p>

5.4 SCOPE OF DELIVERY

Pneumatic piston pump

Consists of:

- Fluid section
- Air motor
- Connection set for air motor - fluid section
- Air pressure regulator for air motor

The scope of delivery also includes:

Separating agent 250 ml; 250 cc

Order no.: 9992504

Declaration of conformity

See Chapter 14.3

Operating manual, German

Order no.: 2333547

Operating manual in the local language

See Chapter 1.3

The delivery note shows the exact scope of delivery. Accessories: see Chapter 12.

5.5 DATA

5.5.1 MATERIALS OF PAINT-WETTED PARTS

Housing	Stainless steel
Piston	Stainless steel and hard chrome
Valve balls	Stainless steel
Valve seats	Carbide
O-rings	PTFE
Packings	Standard PE/ TG

PE = Ultra high molecular weight polyethylene

TG = PTFE with graphite

5.5.2 RECOMMENDED PACKINGS

WAGNER packings are manufactured in four different materials:

Code	Product	Color
L	Leather	dark brown
TG	PTFE with graphite	black
PE	Ultra high molecular weight polyethylene	transparent
T	PTFE	white

Each product has the following properties, which influence the packings:

	L	TG	PE	T
Mechanical stability	poor	good	good	poor
Friction coefficient	poor	very good	good	very good
Sealing force	good*	good	good	good
Chemical resistance	poor	good	very good	very good
Temperature resistance	good	poor - good	very good	poor

* for abrasive products



Standard combinations

Standard pumps: PE/TG

Heavy-duty (high-pressure) pumps: PE/L

Hardener pumps in 2K systems: PE/T

5.5.3 TECHNICAL DATA

	 WARNING
	Exhaust air containing oil! Risk of poisoning if inhaled. Air motor switching problems. → Provide water-free and oil-free compressed air

5.5.3.1 TECHNICAL DATA

Description	Devices	PUMA 8-300	PUMA 3-600	LEOPARD 18-300	LEOPARD 8-600	JAGUAR 38-300
Pump ratio		8 : 1	3 : 1	18 : 1	8 : 1	38 : 1
Volume flow per double stroke (DH)	cm ³ ; cc	300	600	300	600	300
Maximum operating overpressure	MPa bar psi	6.4 64 928	2.4 24 348	13.8 138 2002	6.2 62 899	27 270 3916
Maximum possible strokes in operation	DH/min.	50				
Maximum recommended strokes per minute in continuous operation	DH/min.	30				
Minimum/maximum air inlet pressure	MPa bar psi	0.25-0.8 2.5-8 36-116		0.25-0.77 2.5-7.7 36-112		0.25-0.71 2.5-7.1 36-103
Compressed air quality: free from oil and water		Quality standard 7.5.4 according to ISO 8573.1: 2010 7: Particle concentration 5 – 10 mg/m ³ 5: Humidity: Pressure dew point: ≤ +7 °C 4: Oil content ≤ 5 mg/m ³				
Ø air inlet connection (inside thread)	inch	G 1/2"				G 1"
Minimum Ø of the compressed air supply line	mm; inch	9; 0.35		13; 0.51		25; 0.98
Air consumption at 0.6 MPa; 6 bar; 87 psi per double stroke	nl scf	16.5 0.58		37.3 1.32		79.9 2.82
Air motor piston diameter	mm; inch	100; 3.94		150; 5.9		220; 8.66
Air motor piston stroke	mm; inch	150; 6				
Sound pressure level at maximum permissible air pressure*	dB(A)	78		81		83
Sound pressure level at 0.6 MPa; 6 bar; 87 psi air pressure*	dB(A)	74		78		81
Sound pressure level at 0.4 MPa; 4 bar; 58 psi air pressure*	dB(A)	69		74		76
Product inlet (outside thread)		M36x2	G 1/2"	M36x2	G 1/2"	M36x2
Product outlet (outside thread)	mm	M24x1.5				
Product pH value	pH	3.5 – 9				
Maximum product pressure at pump inlet	MPa bar psi	2 20 290				
Product temperature	°C; °F	+5 ... +80; +41 ... +176				
Ambient temperature	Construction and assembly	+5 ... +50; +41 ... +122				
	Suspension	°C; °F	-20...+60; -4...+140			
Relative humidity	%	10–95 (without condensation)				
Weight	kg; lb	32; 70	35; 77	40; 88	43; 95	56; 123
Allowable inclination for operation	<) °	± 10				

* A-rated sound pressure level measured at 1 m distance, LpA1m according to DIN EN 14462: 2005. Reference measurements have been made by SUVA (Swiss Accident Insurance Institute).

5.5.3.2 MEASUREMENTS AND CONNECTIONS

	Unit	PUMA 8-300	PUMA 3-600	LEOPARD 18-300	LEOPARD 8-600	JAGUAR 38-300
A	mm inch	972 38.3	992 39.1	1034 40.7	1055 41.5	1093 43.0
B	mm inch	169 6.7		240 9.4		304 12
C	mm inch	~ 321 12.6		~ 434 17.1		~ 581 22.9
D	mm inch	335 13.2		380 15		516 20.3
E	mm inch	637 25.1	657 25.9	654 25.7	675 26.6	577 22.7
F	mm inch	134 5.3		192 7.6		244 9.6
G	mm inch	182 7.17		230 9.06		
H	mm inch	80 3.15		110 4.33		
I	mm inch	ø 25 ø 1		20x35 0.8x1.4		20x48 0.8x1.9
J	mm	M6				M8
K		M36x2	G 1½"	M36x2	G 1½"	M36x2
L1	mm	M24x1.5				
L2	inch	G 3/4"				
M	inch	G 1/2"				G 1"
N	inch	G 1/4"				
O	mm inch	106 4.17		129 5.1		135.5 5.3
P	mm inch	96.5 3.80		111.5 4.39		238 9.37
Q	mm inch	ø 9 ø 0.35				
R	mm inch	ø 7 ø 0.28				ø 9 ø 0.35
S	mm inch	149 5.87		167 6.57		206 8.11
T	mm inch	55 2.2		30 1.2		17 0.67

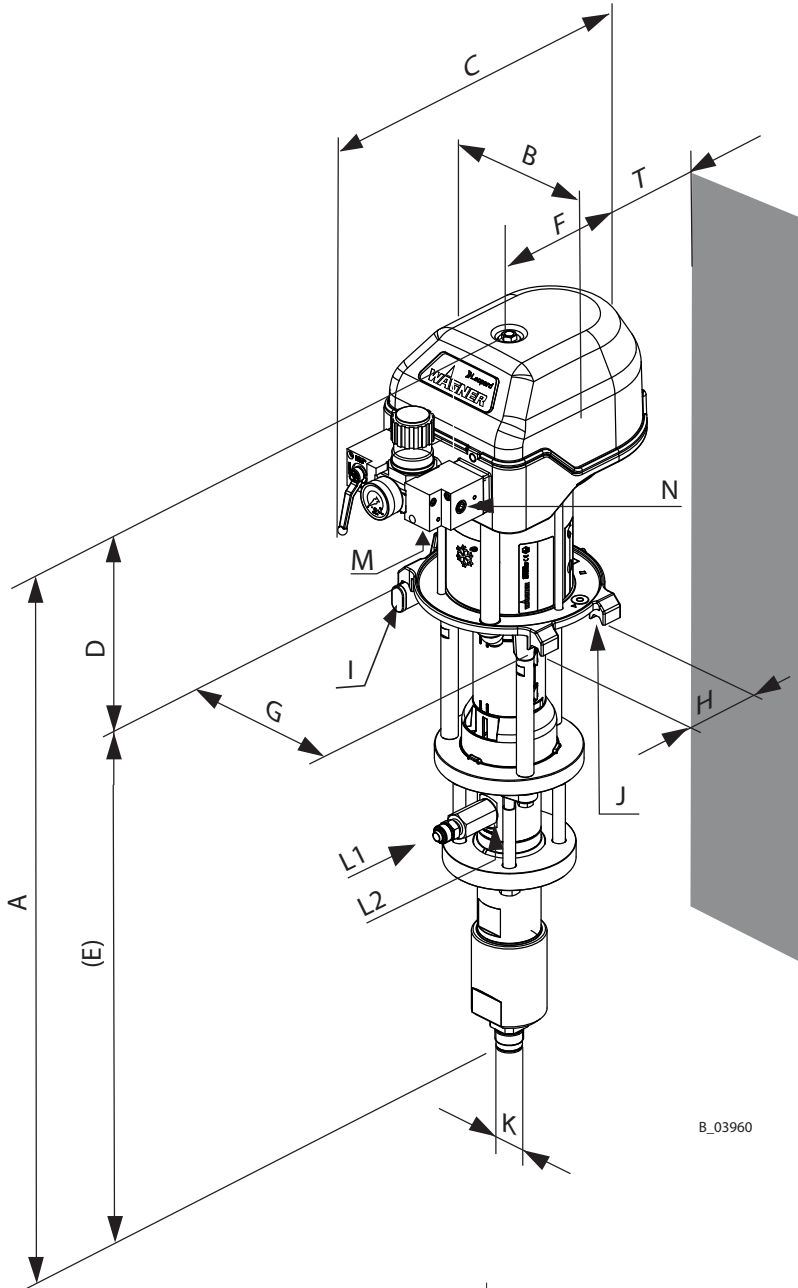

B_03960

**Wall mount
Puma**

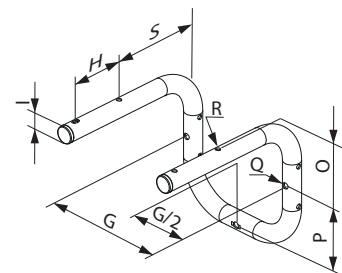

B_03902

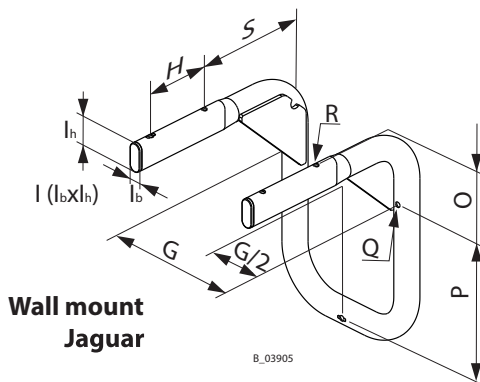

**Wall mount
Jaguar**

B_03905

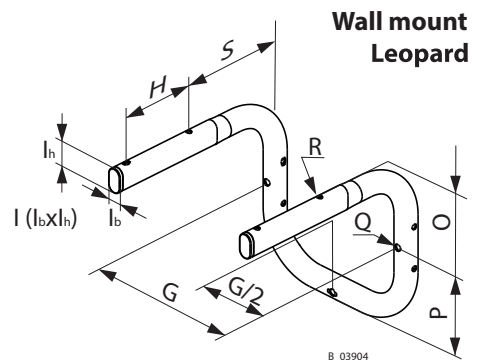

**Wall mount
Leopard**

B_03904



5.5.4 PERFORMANCE DIAGRAMS

Reading example:

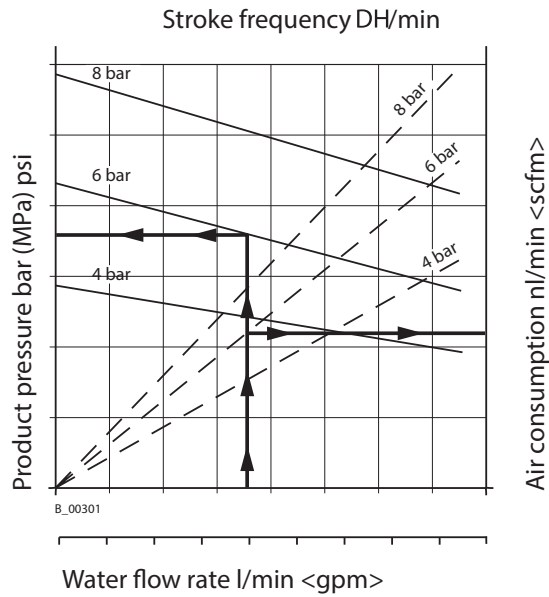

PUMA 8-300

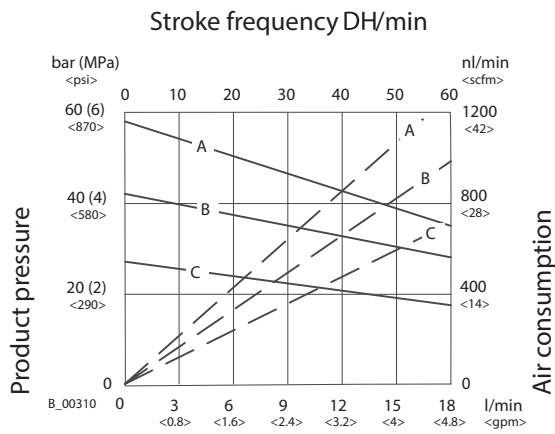

Water flow rate

- A = 8 bar (0.8 MPa; 116 psi) air pressure
- B = 6 bar; 0.6 MPa; 87 psi air pressure
- C = 4 bar; 0.4 MPa; 58 psi air pressure

PUMA 3-600

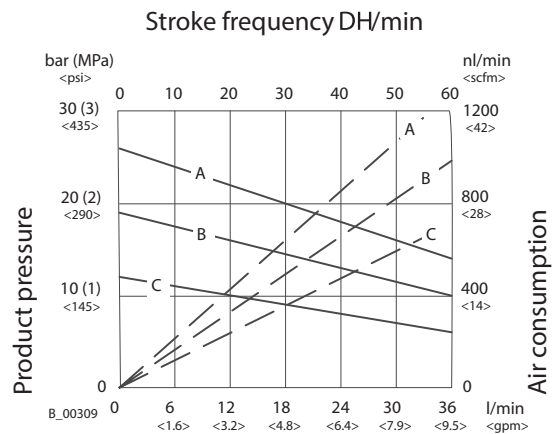

Water flow rate

- A = 8 bar (0.8 MPa; 116 psi) air pressure
- B = 6 bar; 0.6 MPa; 87 psi air pressure
- C = 4 bar; 0.4 MPa; 58 psi air pressure



LEOPARD 18-300

Stroke frequency DH/min

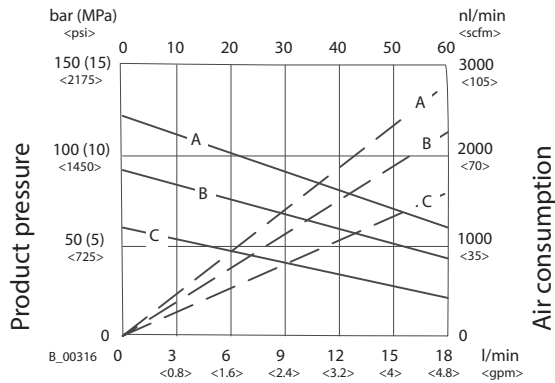

Water flow rate

- A = 7.7 bar (0.77 MPa; 112 psi) air pressure
- B = 6 bar; 0.6 MPa; 87 psi air pressure
- C = 4 bar; 0.4 MPa; 58 psi air pressure

LEOPARD 8-600

Stroke frequency DH/min

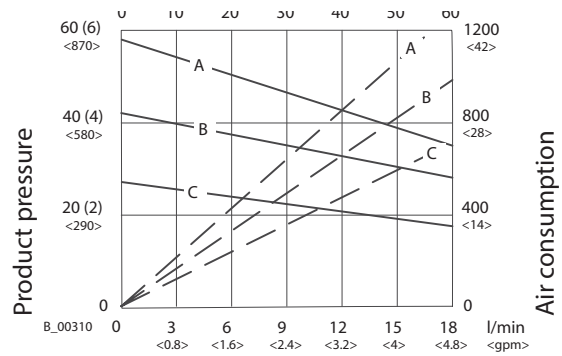

Water flow rate

- A = 7.7 bar (0.77 MPa; 112 psi) air pressure
- B = 6 bar; 0.6 MPa; 87 psi air pressure
- C = 4 bar; 0.4 MPa; 58 psi air pressure

JAGUAR 38-300

Stroke frequency DH/min

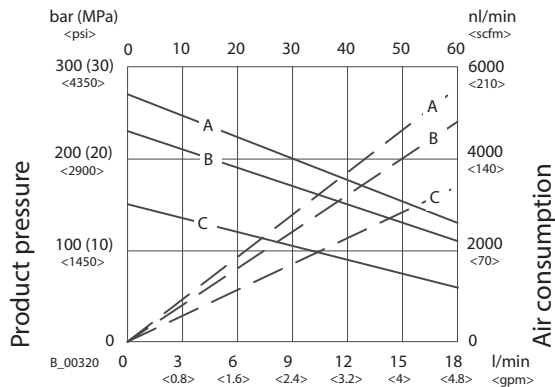

Water flow rate

- A = 7.1 bar (0.71 MPa; 103 psi) air pressure
- B = 6 bar; 0.6 MPa; 87 psi air pressure
- C = 4 bar; 0.4 MPa; 58 psi air pressure

5.6 PRESSURE REGULATOR UNIT

- 1 Pressure regulator
- 2 Ball valve
- 3 Pressure gauge
- 4 Compressed air Inlet

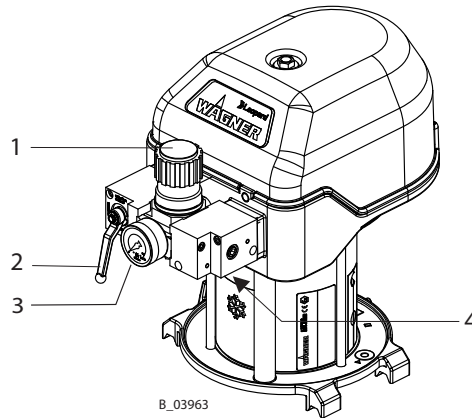
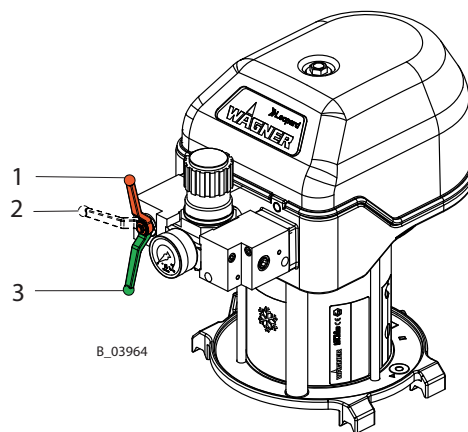

Illustration: Leopard 18-300

**Positions of the ball valve**

- 1 Closed: The operating pressure in the air motor is relieved.
(Control air pressure is still present)
- 2 Closed: the air motor may still be under pressure.
- 3 Open: working position

5.7 PRODUCT FILTER AND RETURN FLOW

So that the complete pressure relief of the pump can be performed (see Chapter 7.5), a high-pressure filter with a return flow or a relief combination, is mandatory.

5.7.1 HIGH-PRESSURE FILTER (OPTION)

To ensure problem-free operation it is recommended that a WAGNER high-pressure filter be used. These have been developed especially for WAGNER pneumatic pumps. The filter inserts can be exchanged depending on the product to be used. The high-pressure filter corresponding to the device can be found in the "Accessories" chapter; the compatible filter inserts can be found in the "Spare parts" chapter.

- 1 Fluid section connection
- 2 Product outlet
- 3 Return line

Preferred installation position of the high-pressure filter

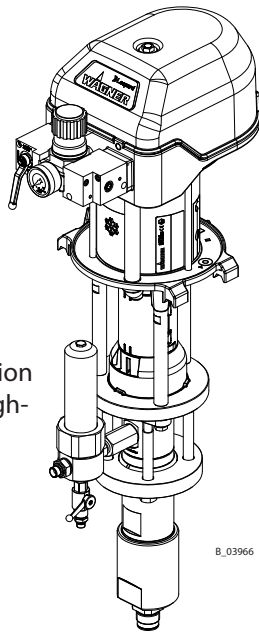

B_03966

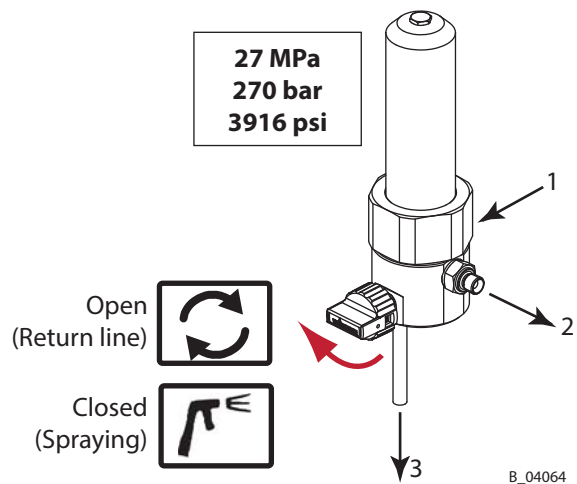
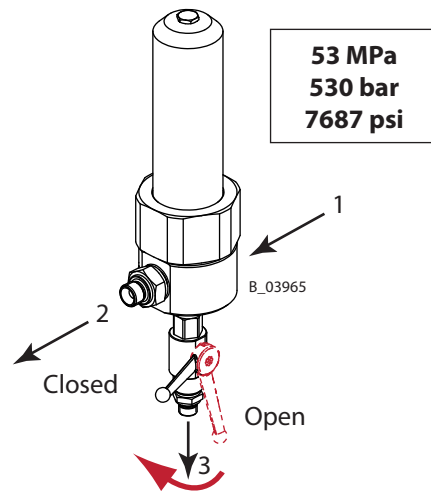

5.8 STROKE COUNT (OPTION)

Each air motor has a 1/8" air connection with which the air pressure in the lower air motor chamber can be measured. This signal can be used for counting the strokes in an external control, for example.

The pressure signal corresponds to the set working air pressure and is available during the complete upwards stroke of the pump. If both of the signal flanks are evaluated, the upper and lower reversal point can be determined. A 4/2-mm; 0.16/0.08-inch air hose is used as an air signal line.

Pneumatic pumps: Puma and Leopard

Pos	Order No.	Designation
1	9998675	Threaded plug
2	9999066	Male stud elbow
3	9982072	Air hose (per meter)
4	9943049	Pneumatic pre-selection counter

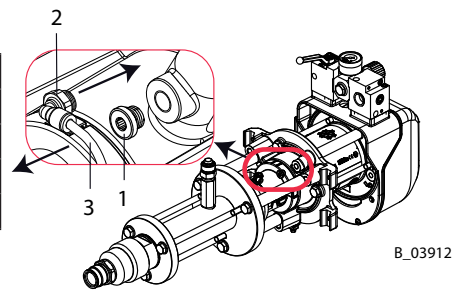

Pneumatic pumps: Jaguar

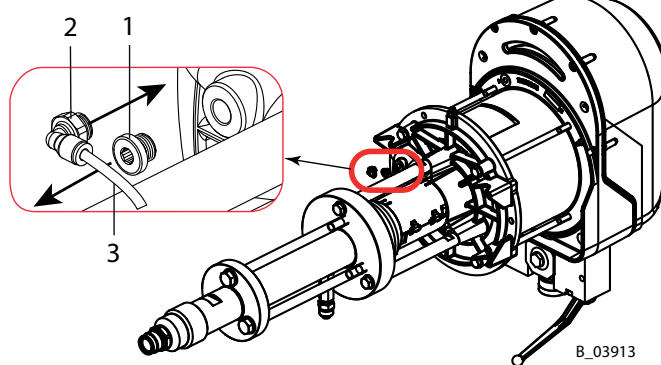
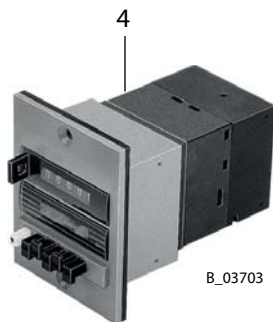

5.9 FEED PUMP (OPTION)

A feed pump can be used with high-viscosity products or longer feed lines.

Dimensioning of the feed pump

→ The IceBreaker piston pumps pump the working material to the product output with up and down strokes but only draw in new product on the up stroke. The feed pump therefore has to pump twice the volumetric flow.

Main pump protection

→ The maximum product pressure at the pump inlet of the IceBreaker pump may not be exceeded.

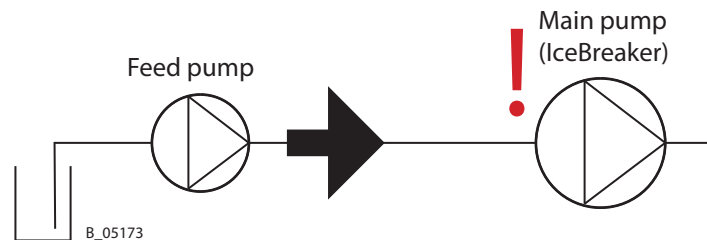

Protection of feed pump

→ If the maximum pressure of the feed pump is lower than the maximum pressure of the main pump, this could be exceeded if the main pump malfunctions. The feed pump and connection line must therefore be protected from excessive overpressure. An overpressure valve must then be installed between the feed pump and main pump.

→ Observe the flow direction during installation.

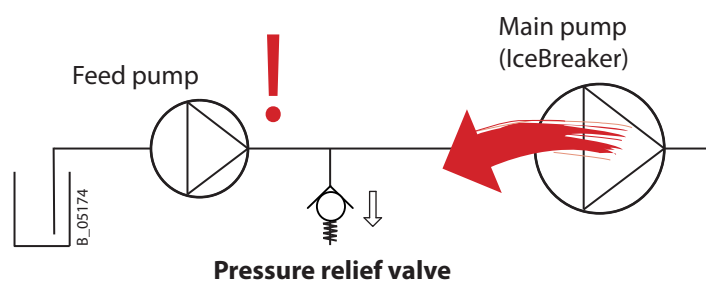

→ The pressure-relief valve must be cleaned regularly and after each activation: Flush with solvent.

Installation sets and compatible feed pumps

→ See assembly manual "Feed pump installation sets", Order No. 2357584.

6 ASSEMBLY AND COMMISSIONING

6.1 TRAINING ASSEMBLY/COMMISSIONING STAFF

- The assembly and commissioning staff must have the technical skills to safely commission the device.
- When assembling, commissioning and carrying out all work, read and follow the operating manuals and safety regulations for the additionally required system components.

A skilled person must check to ensure that the device is in a reliable state after it is installed and before commissioning.

6.2 STORAGE AND INSTALLATION CONDITIONS

Until the point of assembly, the device must be stored in a dry location, free from vibrations and with a minimum of dust. The device must be stored in closed rooms. For specifications on temperatures and relative humidity, see Technical Data.

Long-term storage: Thoroughly clean the pump, if a long-term decommissioning is planned. See Chapter "Cleaning". For recommissioning, proceed according to following chapters.

6.3 TRANSPORTATION



Only the pump without trolleys may be lifted by the ring nut or lifting eye bolt (see accessories) and transported short distances.

Puma and Leopard: The pump can be moved on a trolley (4"/6" trolley) or manually without lifting equipment or a crane.

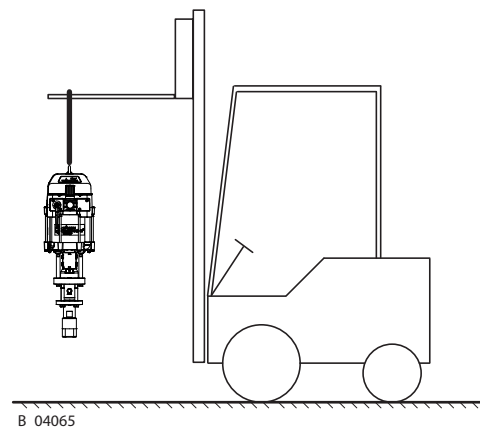
Jaguar: The pump must be moved on a trolley (heavy-duty PC trolley) or with lifting equipment or a crane.



B_04065

	 WARNING
	<p>Inclined ground! Risk of accidents if the device rolls away/falls.</p> <ul style="list-style-type: none"> → Position the trolley with the piston pump horizontally. → If the surface is inclined, position the feet of the trolley towards the gradient. → Secure the trolley.

6.4 ASSEMBLING THE PUMP

Note:

This pump can be used as part of a spraying or feed system. The individual components are shown in the accessories, or can be arranged with a spraypack configurator. The nozzles must be selected according to the gun operating manual.

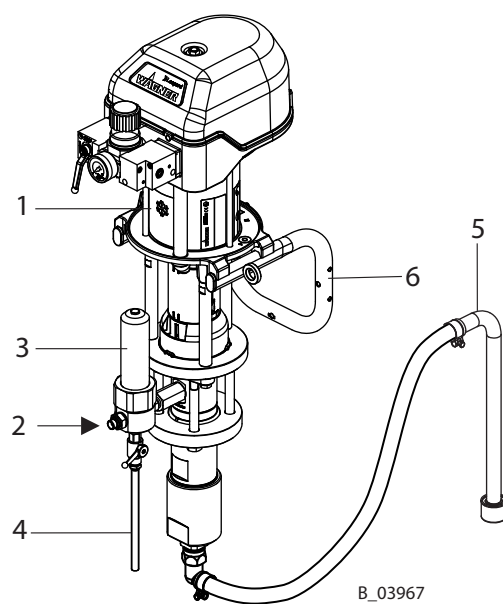
**Procedure:**

1. Mount the pump on a frame, a trolley or a wall mount (6).
2. Mount high-pressure filter (3).
3. Mount suction system (5).
4. Mount return tube (4) or return hose.
5. Connect to product supply system or high-pressure hose and gun in accordance with gun operating manuals (2).

6.4.1 VENTILATION OF THE SPRAY BOOTH

Observe the safety instructions in Chapter 4.1.3.

- Operate the device in a spray booth approved for the working materials.
 - or –
- Operate the device on an appropriate spraying wall with the ventilation (extraction) switched on.
- Observe national and local regulations for the exhaust air speed.

6.5 GROUNDING

	WARNING
	<p>Discharge of electrostatically charged components in atmospheres containing solvents! Explosion hazard from electrostatic sparks.</p> <ul style="list-style-type: none"> → Clean the piston pump only with a damp cloth. → Ground all device components. → Ground the work pieces to be coated.

	WARNING
	<p>Heavy paint mist if grounding is insufficient! Danger of poisoning. Insufficient paint application quality.</p> <ul style="list-style-type: none"> → Ground all device components. → Ground the work pieces to be coated.

Grounding scheme (example)

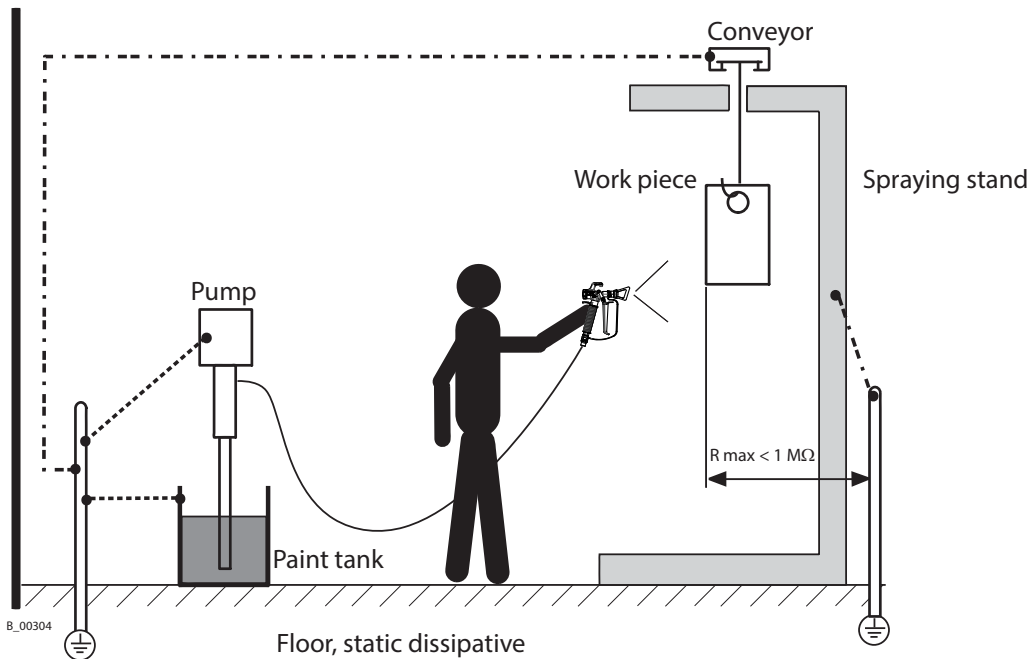

Cable cross sections

Pump	4 mm ² ; AWG 12	Conveyor	16 mm ² ; AWG 6
Product tank	6 mm ² ; AWG10	Booth	16 mm ² ; AWG 6
		Spraying stand	16 mm ² ; AWG 6

Safe operation of the IceBreaker pump is only guaranteed with a ground connection.
Connect all ground cables using a short and direct route.

Procedure:

1. Ground the pump, connect the grounding cable to potential equalization on-site.
2. Ground the product tank.
3. Ground the other parts of the system to an on-site grounding connection. 16 mm²; AWG 6

Ex zone

All devices and equipment must be suitable for use in potentially explosive areas.

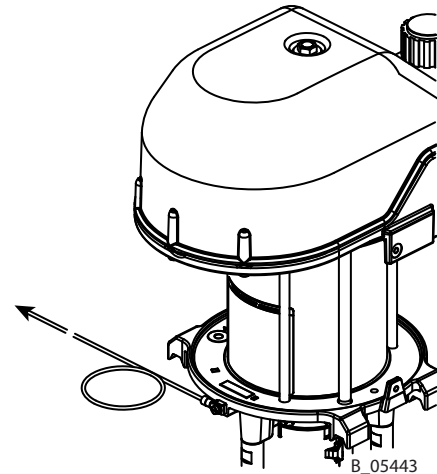
**6.6 COMMISSIONING**

- Observe all safety regulations in accordance with Chapter 4 and Chapter 7.2.
- Emergency stop, see Chapter 7.3.

Preparation

Before every start-up, the following points should be observed as laid down in the operating manual:

- Secure gun with safety clip.
- Check the permissible pressures.
- Check all connections for leaks.
- Check hoses for damage in accordance with Chapter 8.2.8.

Fill the pump with flushing agent

The devices are tested during manufacturing with emulsifying oil, pure oil or solvent. Possible residues must be flushed out of the circuits with a solvent (flushing agent) before commissioning.

- Fill the separating agent in accordance with Chapter 8.2.4.
- Fill the empty device with flushing agent in accordance with Chapter 8.2.6.

Pressure tightness test

- Gradually increase the pressure in pump with the pressure regulator until maximum pressure is reached. Maintain the pressure for 3 minutes and check all connection points for leaks.
- Depressurization in accordance with Chapter 7.5.

Filling with working material

- In accordance with Chapter 7.6.1.

7 OPERATION



7.1 TRAINING THE OPERATING STAFF



- The operating staff must be qualified and fit to operate the entire system.
- The operating staff must be familiar with the potential risks associated with improper behavior as well as the necessary protective devices and measures.
- Before work commences, the operating staff must receive appropriate system training.

7.2 SAFETY INSTRUCTIONS

Before carrying out any work, the following points must be observed in accordance with the operating manual:

- Observe all safety regulations in accordance with Chapter 4.
- Carry out commissioning in accordance with Chapter 6.6.

	 WARNING
	<p>Incorrect operation! Risk of injury and damage to the device.</p> <ul style="list-style-type: none"> → If contact with lacquers or cleaning agents causes skin irritation, appropriate precautionary measures must be taken, e.g., wearing protective clothing. → The footwear worn by operating staff must comply with EN ISO 20344. The measured insulation resistance must not exceed 100 megohms. → The protective clothing, including gloves, must comply with EN ISO 1149-5. The measured insulation resistance must not exceed 100 megohms.

	 WARNING
	<p>Unintentional putting into operation! Risk of injury</p> <p>Before any work on the device, in the event of work interruptions and malfunctions:</p> <ul style="list-style-type: none"> → Relieve the pressure from the spray gun and unit. → Secure the spray gun against actuation. → Switch off the energy/compressed air supply. → Disconnect the control unit from the network. → In the event of functional faults: remedy the fault as described in the "Troubleshooting" chapter.

	WARNING
	<p>Gas mixtures can explode if there is an incompletely filled pump! Danger to life from flying parts.</p> <ul style="list-style-type: none"> → Ensure that the pump and suction system are always completely filled with flushing agent or working material. → Do not spray the device empty after cleaning.

7.2.1 GENERAL RULES FOR MAKING ADJUSTMENTS TO THE SPRAY GUN

→ Observe the operating manual of the spray gun.

	WARNING
	<p>High pressure spray jet! Danger to life from injecting paint or solvent.</p> <ul style="list-style-type: none"> → Never reach into the spray jet. → Never point the spray gun at people. → Consult a doctor immediately in the event of skin injuries caused by paint or solvent. Inform the doctor about the paint or solvent used. → Never seal defective high-pressure parts; instead relieve the pressure from them and replace them immediately. → Use personal protective equipment (protective clothing, gloves, eyewear and respiratory protection).

7.3 EMERGENCY STOP

In the case of unforeseen occurrences:

- close ball valve (2);
- open return valve (3).

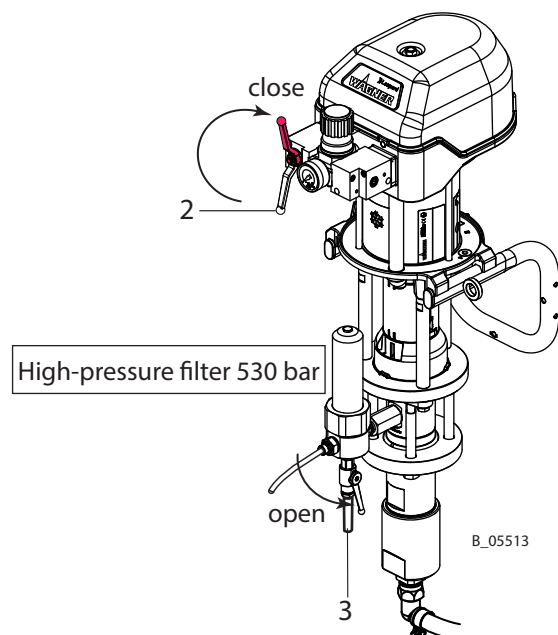
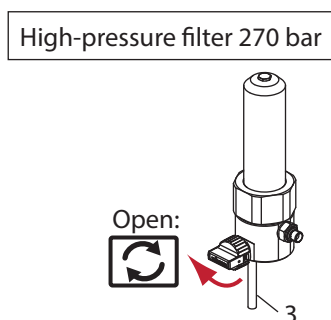

7.4 SPRAYING

1. Visual check: personal safety equipment, grounding and all devices ready to use.
2. Secure the spray gun and place the nozzle in the gun.
3. Set required working pressure on the pressure regulator (1).
4. Slowly open the ball valve (2).
5. Optimize the spraying results as laid down in the gun instructions.
6. Start work process.

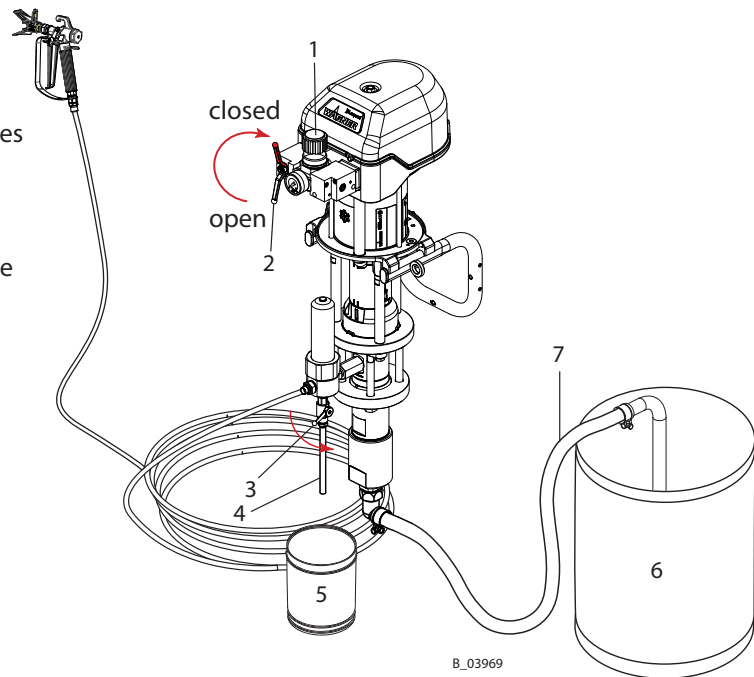
**7.5 PRESSURE RELIEF/WORK INTERRUPTION**

1. Close the spray gun.
2. Close ball valve (2).
3. Release the system by opening the gun.
 - Attention: If a blocked nozzle is preventing relief, first carry out the additional steps 4 and 5, then clean the nozzle.
4. Close and secure gun.
5. Open and close the return valve (3) slowly to completely depressurize the system.

If the system has been used with 2K products:

NOTICE

Hardened working material in the spraying system when 2K product is processed!
Destruction of pump and injection system.

- Follow the manufacturer's processing rules, particularly regarding the pot life.
- Flush thoroughly before the end of the pot life.
- The pot life is decreased by warmth.

7.6 BASIC FLUSHING

Procedure

1. Visual check: personal safety equipment, grounding and all devices ready to use.
2. Place an empty, grounded collection tank (5) under the return tube (4).
3. Place the suction hose (7) in the grounded tank with flushing agent (6).
4. Adjust the pressure regulator (1) to approx. 0.05 MPa; 0.5 bar; 7.25 psi.

Flush via the return flow valve

5. Open return valve (3).
6. Slowly open the ball valve (2).
7. Adjust the air pressure on the pressure regulator (1) so that the pump runs smoothly.
8. Flush the system until clean flushing agent flows into the tank (5).
9. Close ball valve (2).
10. As soon as there is no pressure remaining in the system, close the return valve (3).

Flush using gun

11. Point the spray gun, without nozzle, into the tank (5) and open it.
12. Slowly open the ball valve (2).
13. Rinse until clean flushing agent flows from the gun.
14. Close ball valve (2).
15. As soon as there is no pressure in the system, close the gun.
16. Secure the gun.
17. Dispose of the contents of the tank (5) according to the local regulations.

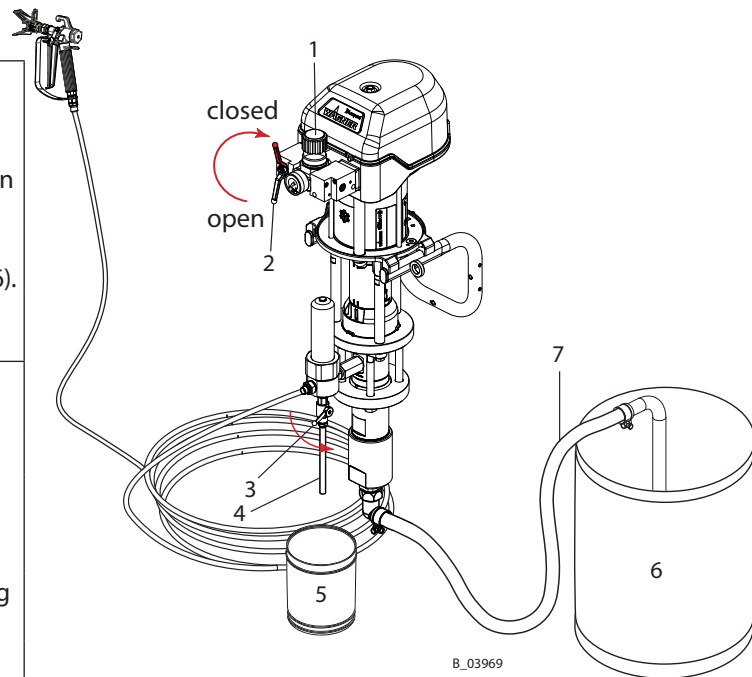

Flush regularly

Regular flushing, cleaning and maintenance ensures the pumps' high pumping and suction capacity.

Hardener pumps in 2K systems

Do not flush hardener pumps with water, rather only using suitable flushing agents (solvents).

7.6.1 FILLING WITH WORKING MATERIAL

After basic flushing, the system can be filled with working material. Proceed according to Chapter 7.6, but use working material instead of flushing agent.

8 CLEANING AND MAINTENANCE

8.1 CLEANING

8.1.1 CLEANING STAFF

Cleaning work should be undertaken regularly and carefully by qualified and trained staff. They should be informed of specific hazards during their training.

The following hazards may arise during cleaning work:

- Health hazard from inhaling solvent vapors
- Use of unsuitable cleaning tools and aids

8.1.2 SAFETY INSTRUCTIONS

- Clean the piston pump only with a damp cloth.
- Observe safety instructions in Chapter 4.



DANGER

Incorrect maintenance/repair!



Danger to life and equipment damage.

- Only a WAGNER service center or a suitably trained person may carry out repairs and replace parts.
- Only repair and replace parts that are listed in the "Spare parts" chapter and that are assigned to the unit.
- Before all work on the device and in the event of work interruptions:
 - Relieve pressure from spray guns and devices.
 - Secure spray guns against actuation.
 - Switch off the energy/compressed air supply.
 - Disconnect the control unit from the mains.
- Observe the operating and service manual for all work.



8.1.3 DECOMMISSIONING AND CLEANING

The device should be cleaned for maintenance purposes. Ensure that no remaining product dries on and sticks to the device.

1. Carry out work interruption → Chapter 7.5.
2. Carry out basic flushing → in accordance with Chapter 7.6.
3. Empty the pump in a controlled manner → in accordance with Chapter 8.2.5.
4. Maintain the gun according to the operating manual.
5. Clean and check the suction system and the suction filter.
6. When using a material filter, check filter insert and filter housing and clean or replace them. → Chapter 8.2.7.
7. Clean the outside of the system.

	 WARNING
	<p>Brittle filter pressure regulator! The tank on the filter pressure regulator becomes brittle through contact with solvents and can burst. Flying parts can cause injury.</p> <p>→ Do not clean the tank on the filter pressure regulator with solvents.</p>

8. Fully assemble the system.
9. Check fill level of the separating agent → Chapter 8.2.4.
10. Fill the system with flushing agent in accordance with Chapter 8.2.6.

	 WARNING
	<p>Gas mixtures can explode if there is an incompletely filled pump! Danger to life from flying parts. Ignition of potentially explosive surrounding atmosphere.</p> <p>→ Ensure that the pump and suction system are always completely filled with flushing agent or working material. → Do not spray the device empty after cleaning.</p>

8.1.4 LONG-TERM STORAGE

When storing the device for longer periods of time, it is necessary to thoroughly clean it and protect it from corrosion. Replace the water or solvent in the product pump with a suitable preservative, fill separating agent cup with separating agent.

Procedure:

1. Carry out points 1 to 9 of Chapter 8.1.3 "Decommission and clean".
2. Fill the system with preservative in accordance with Chapter 8.2.6.
3. Empty the pump in a controlled manner in accordance with Chapter 8.2.5 and seal the openings.

8.2 MAINTENANCE

8.2.1 MAINTENANCE STAFF

Maintenance work should be undertaken regularly and carefully by qualified and trained staff. They should be informed of specific hazards during their training.

The following hazards may arise during maintenance work:

- Health hazard from inhaling solvent vapors
- Use of unsuitable tools and aids

An authorized person must ensure that the device is checked for being in a reliable state after maintenance work is completed.

8.2.2 SAFETY INSTRUCTIONS

→ Observe the safety instructions in Chapter 4 and Chapter 8.1.2.



Prior to maintenance

It should be ensured that the device is in the following state before carrying out any work on it:

- Release pressure from the pump, high-pressure hose and gun.
- The gun should be secured with the safety clip.
- The air supply should be interrupted.

After maintenance

- Commissioning in accordance with Chapter 6.6.
- According DGUV regulation 100-500:
- The liquid ejection devices should be checked by an expert (e.g., WAGNER service technician) for their safe working conditions as required and at least every 12 months.
 - For shut down devices, the examination can be suspended until the next start-up.

	 DANGER
	<p>Incorrect maintenance/repair! Danger to life and equipment damage.</p> <p>→ Repair or replacement of devices or parts of devices are only allowed to be performed outside the hazard area by qualified personnel.</p>

8.2.3 REGULAR MAINTENANCE WORK

1. Check the level of separating agent in the separating agent cup every day, and top up if necessary.
2. Check and clean the high-pressure filter every day or as required. (See Chapter 8.2.7).
3. Every shut down should be carried out as laid down in Chapter 8.1.3!
4. Check hoses, pipes, and couplings every day and replace if necessary.

If the pump has to be emptied for maintenance work, proceed according to Chapter 8.2.5.

The service manual is available in German and English.
For order number see Chapter 1.3.

8.2.4 FILLING SEPARATING AGENT

NOTICE

Piston pump dry run!

High wear/damage to the packings.
Paint or solvent can escape if the seals are dry.

→ Ensure that the separating fluid tank is filled with sufficient separating fluid. Filling level 1 cm; 0.4 inch under the cup edge.

Place the supplied separating agent into the separating agent cup.

Filling level: 1 cm; 0.4 inch under the cup edge.

Separating agent: Order no. 9992504

Inclination angle of the pump

Maximum permissible inclination of pump for moving, transportation, etc. after filling it with separating agent $\pm 30^\circ$.

The pump must be vertical during operation.

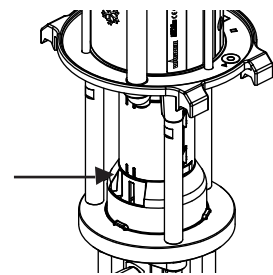

B_03970

8.2.5 EMPTYING THE PUMP

	<p>⚠ WARNING</p> <p>Gas mixtures can explode if there is an incompletely filled pump! Danger to life from flying parts. Ignition of potentially explosive surrounding atmosphere.</p> <p>→ Empty the device slowly and in a controlled manner. → Avoid potentially explosive atmosphere in the surroundings.</p>
---	---

→ If the pumping product becomes heated, switch off all heaters and let the product cool off.

1. Visual check: personal safety equipment, grounding and all devices ready to use.
2. Carry out basic flushing in accordance with Chapter 7.6.
3. Place grounded collection tank (5) under the return tube (4).
4. Place the suction hose (7) in an empty, grounded tank (6).
5. Close pressure regulator (1) (0 MPa; 0 bar; 0 psi).

Empty using return line

6. Open return valve (3).
7. Slowly open the ball valve (2).
8. Slowly turn air pressure up on the pressure regulator (1) and only until the pump is running normally (approx. 0.05 MPa; 0.5 bar; 7.25 psi).
9. Be ready for the switch from working material to air. Turn down pressure regulator (1) far enough that the pump is still running normally (approx. 0–0.05 MPa; 0–0.5 bar; 0–7.25 psi).
10. As soon as working material is no longer flowing from the return tube (4), close ball valve (2).
11. Close return valve (3).

Empty up to the gun

12. Point the gun, without nozzle, into tank (5) and open it.
13. Slowly open the ball valve (2). Be ready for the switch from working material to air.
14. As soon as working material is no longer flowing from the return tube, close the ball valve (2).
15. Close and secure gun.
16. Depressurization in accordance with Chapter 7.5.
17. Dispose of the contents of the tank (5) according to the local regulations.

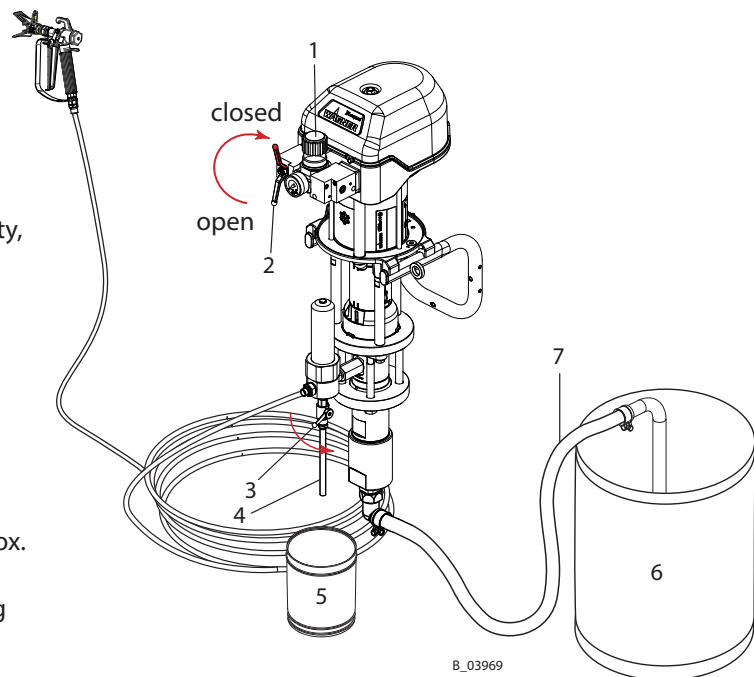

8.2.6 FILLING THE EMPTY PUMP

	<p>⚠ WARNING</p> <p>Gas mixtures can explode if there is an incompletely filled pump! Danger to life from flying parts. Ignition of potentially explosive surrounding atmosphere.</p> <p>→ Empty and fill the device slowly and in a controlled manner. → Avoid potentially explosive atmosphere in the surroundings.</p>
---	--

1. Visual check: personal safety equipment, grounding and all devices ready to use.
2. Place grounded collection tank (5) under the return tube (4).
3. Place the suction hose (7) in a grounded tank with working material (6).

Note:

If the pump is equipped with a rigid suction system, it should only be dipped in into the working material up to the middle of the inlet housing at the maximum!

4. Close pressure regulator (1) (0 MPa; 0 bar; 0 psi).
5. Open return valve (3).
6. Slowly open the ball valve (2).
7. Slowly turn the air pressure up on the pressure regulator (1) and only until the pump is running normally (approx. 0–0.05 MPa; 0–0.5 bar; 0–7.25 psi). Be ready to switch from working material to air and prevent back spray.
8. Close ball valve (2) as soon as pure working material starts coming from the return tube (4).
9. Close return valve (3).
10. Point the spray gun, without nozzle, into the tank (5) and open it.
11. Slowly open the ball valve (2). Be ready to switch from working material to air and prevent back spray.
12. As soon as pure working material without air bubbles is flowing, close ball valve (2).
13. Close and secure the spray gun.
14. Depressurization in accordance with Chapter 7.5.
15. Dispose of the contents of the tank (5) according to the local regulations.

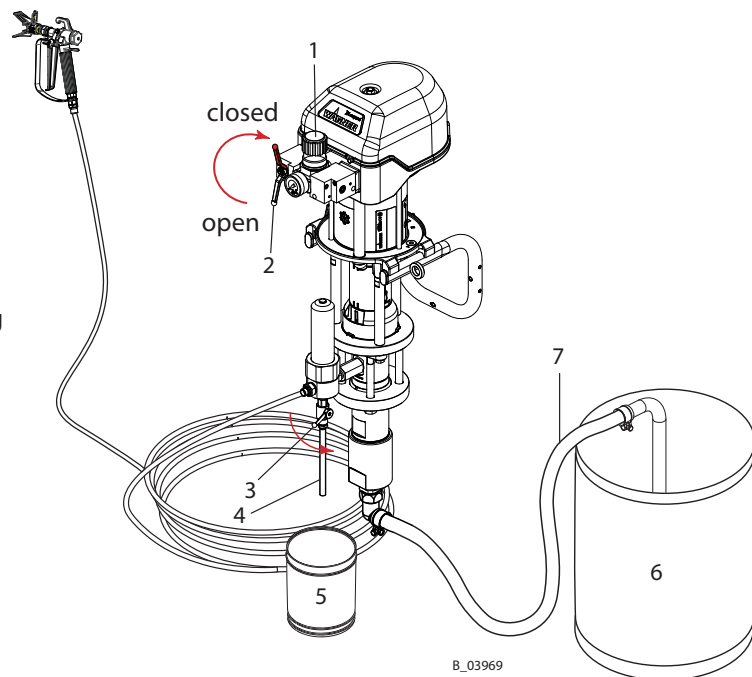



8.2.7 HIGH-PRESSURE FILTER 270 BAR AND 530 BAR

1. Flush the pump and HP filter in accordance with Chapter 7.6, and while doing so:
 - At the preferred filter installation position: Flush via the return flow valve (1). This produces a large flow. As a result, the flushing agent also flows through the upper part of the filter cartridge (11). Pressure regulator approx. 0.15 MPa; 1.5 bar; 22 psi.
 - At the reversed filter installation position: Flush using the gun. This is required in the case of a reversed installation position so that the flushing agent flows through the filter cartridge (11). Maximize the flow (remove the nozzle, open the dosing valve if necessary).
2. Empty the pump in a controlled manner in accordance with Chapter 8.2.5.
3. Place the grounded collection tank under the HP filter.
4. Loosen the union nut (3) (wrench size 70).
5. Unscrew the union nut (3) and lift slightly so that it does not get dirty in the next step.
6. Remove the filter housing (2) with the union nut (3). The cone spring (12) remains in the filter housing (2). If the O-ring (5) is not damaged, it remains on the filter housing (2).
7. Remove the filter cartridge (11) and filter support (10) from the filter housing (2).
8. Clean all parts:
 - Place the filter cartridge (11) and filter support (10) in solvent. Clean using brush.
 - Fill the filter housing (2) approx. 1/3 full with solvent, secure wearing a glove and shake well.
 - Clean the distribution housing (7) using a brush.
9. If necessary, replace the O-ring (5) and/or filter cartridge (11). Order No., see Chapter 13.6 or 13.7.
10. Assemble all parts in reverse order. While doing so:
 - Coat the thread of the distribution housing (7) with anti-seize paste**.
 - Coat the O-ring (5) and pressure ring (21) with Mobilux® EP2**.
 - Observe the installation position of the filter cartridge (11): Push the closed end with the filter identification ahead into the filter housing (2).
 - Make sure that the cone spring (12) is in the filter housing (note the installation position). Press on the cone spring after inserting the filter cartridge (11) and filter support (10); the spring action must be noticeable.
 - Tighten the union nut (3) by hand.
11. Fill the pump in accordance with Chapter 8.2.6.

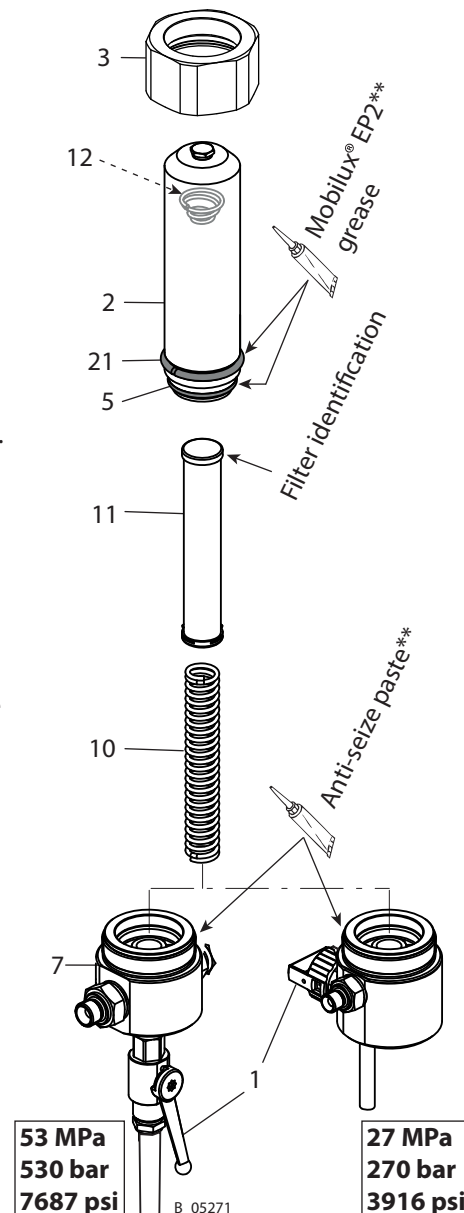
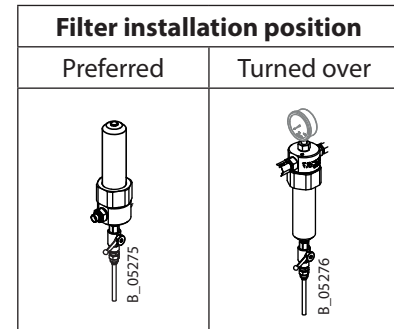
** Order No., see Chapter 10.2.



8.2.8 PRODUCT HOSES, TUBES AND COUPLINGS

	 DANGER
	<p>Bursting hose, bursting threaded joints! Danger to life from injection of product and from flying parts.</p> <ul style="list-style-type: none"> → Ensure that the hose material is chemically resistant to the sprayed products and the used flushing agents. → Ensure that the spray gun, threaded joints, and product hose between the device and the spray gun are suitable for the generated pressure. → Ensure that the following information can be seen on the hose: <ul style="list-style-type: none"> - Manufacturer - Permissible operating pressure - Date of manufacture.

The service life of the complete hoses between product pressure generator and application device is reduced due to environmental influences even when handled correctly.

- Check hoses, pipes, and couplings every day and replace if necessary.
- Before every commissioning, check all connections for leaks.
- Additionally, the operator must regularly check the complete hoses for wear and tear as well as for damage at intervals that he/she has set. Records of these checks must be kept.
- Undamaged complete hoses are to be replaced when one of the two following intervals has been exceeded:
 - 6 years from the date of the hose crimping (see fitting embossing).
 - 10 years from the date of the hose imprinting.

Fitting embossing (if present)	Meaning
xxx bar	Pressure
yymm	Crimping date (year/month)
XX	Internal code

Hose imprinting	Meaning
WAGNER	Name / Manufacturer
yymm	Date of manufacture (year/ month)
xxx bar (xx MPa) e.g., 270 bar (27 MPa)	Pressure
XX	Internal code
DNxx (e.g., DN10)	Nominal diameter

9 TROUBLESHOOTING AND RECTIFICATION

Problem	Cause	Remedy
The pump does not work	Air motor does not work or stops.	Open and close ball valve on the pressure regulator unit or briefly disconnect compressed air supply.
	No pressure indication on the pressure gauge (air pressure regulator defective).	Disconnect compressed air supply briefly or repair or change pressure regulator.
	Spray nozzle is clogged.	Clean the nozzle according to the instructions.
	Insufficient compressed air supply.	Check compressed air supply.
	Filter insert in spray gun or high-pressure filter is clogged.	Clean the parts and use a suitable working material.
	Fluid section or high-pressure hose are blocked (e.g., 2K product hardened).	Dismount and clean fluid section, replace high-pressure hose.
	Grease in spool and sleeve assembly.	Degrease spool and sleeve assembly.
	Pump stops at the stroke end occasionally.	Check detent element (see service manual).
Poor spray pattern	See the gun instructions.	
Irregular operation of product pump: spray jet collapses (pulsation)	Viscosity is too high.	Dilute the working material.
	Spraying pressure is too low.	Increase incoming air pressure. Use a smaller nozzle.
	Valves are clogged.	Clean product pump, if necessary leave to soak in flushing agent.
	Foreign body in suction valve.	Dismantle suction valve housing, clean and check valve seat.
	Diameter of compressed air line too small.	Assemble a larger supply line. → Technical data, Chapter 5.5.3.
	Valves, packings, or pistons are worn out.	Replace the parts.
	Control air filter or work air filter is clogged.	Check filter and clean it if necessary.
Pump is running uniformly, but does not take in any working material	The suction system's union nut is loose; the pump is taking in air.	Tighten union nut.
	Suction filter is clogged.	Clean filter.
	Ball in suction or piston valve is sticking.	Clean with flushing agent (if necessary vent device).
Pump runs when the gun is closed	Packings, valves, or pistons are worn out.	Replace the parts.
The air motor is iced up	There is a lot of condensation water in the air supply.	Install a water separator.

If none of the causes of malfunction mentioned are present, the defect can be remedied by a WAGNER Service Center.

10 REPAIR

10.1 REPAIR PERSONNEL

Repair work should be undertaken carefully by qualified and trained personnel. They should be informed of specific hazards during their training. The repairs must be carried out in accordance with the corresponding service manual.

The following hazards may arise during repair work:

- Health hazard from inhaling solvent vapors
- Use of unsuitable tools and aids

A skilled person must check to ensure that the device is in a reliable state after it is repaired.

10.2 MOUNTING MATERIALS

In Chapter 13 the order numbers for device spare parts can be found, as well as for wearing parts such as seals.

→ Use torques, greases and glues in accordance with Chapter 13.

Mounting materials

Order No.	Quantity	Designation	Smaller tanks
9992590	1 pc \triangleq 50 ml	Loctite® 222	
9992511	1 pc \triangleq 50 ml	Loctite® 243	
9992831	1 pc \triangleq 50 ml	Loctite® 542	
9998808	1 pc \triangleq 18 kg !	Mobilux® EP 2 grease	400 g tube \triangleq Order No. 2355418
9992616	1 pc \triangleq 1 kg can	Molykote® DX grease	50 g tube \triangleq Order No. 2355419
9992609	1 pc \triangleq 100 g	Anti-seize paste	
9992816	1 pc \triangleq 70 g	Miranit contact adhesive	

Brand notice

The brands specified in this document are property of the respective owners. Loctite®, for example, is a registered brand of Henkel.

11 DISPOSAL

When the equipment must be scrapped, please differentiate the disposal of the waste materials.

The following materials have been used:

Steel	Aluminum	Plastics	Carbide
-------	----------	----------	---------

Consumable products

Consumable products (lacquers, adhesives, flushing and cleaning agents) must be disposed of in accordance with all applicable legal requirements.

12 ACCESSORIES

12.1 ACCESSORIES FOR PRODUCT OUTLET

Accessories list		PUMA 8-300	PUMA 3-600	LEOPARD 18-300	LEOPARD 8-600	JAGUAR 38-300	
Pos	K	Designation	Order No.	Order No.	Order No.	Order No.	
A		Piston pump PE/TG	2329527	2329531	2329497	2329533	2329509
A		Piston pump PE/T	2329529	-	2329499	-	2329507
1		Separating agent 250 ml; cc	9992504				
2		Separating agent 10 L; 2.6 gal	356940				
3		Grounding cable 3 m; 9.8 ft	236219				
4		HP filter DN12-PN530-SSt	2329025				
5		HP filter DN12 PN530-SSt with carbon steel ball valve	2335334				
6		Adapter G3/8"-NPS 3/8"	2332620				
7	◆	Return tube DN6-G1/4"-100mm-PE	2331752				
8	◆	Return hose DN6-PN310-G1/4"-PA	2329046				
9	◆	Circulation hose DN6-PN310-G1/4"-1.8m-PA	2331017				
10	◆	Circulation hose DN6-PN310-G1/4"-2.8m-PA	2331014				
13		Hose sleeve DN13	9985619			--	
14		Plug-in fitting	9998813			--	
15		Quick release coupling with hose connector DN 13	9998812			--	
16		Outside thread grommet 1"-NW25	--			9985671	
17		Sealing ring 1"	--			9974135	
18		Regulator lock	2334956	2334957		2334958	
19		Lifting eye bolt	9907133				
20		Air coat regulator	--	2328611	--	2328611	
21		AirCoat filter regulator, complete	--	2333478	--	2333478	
22		Ball valve DN7-PN10-G1/4-R1/4-CB	--	2335815	--	2335815	
23		Loctite 542, 50ml; 50cc	--	9992831	--	9992831	
24		HP filter DN10-PN270-SSt	--	2329024	--	2329024	
25		Adapter G1/4"-NPS1/4"	--	2332619	--	2332619	
26		Y-distributor, complete	2339850				

◆ = Wearing parts

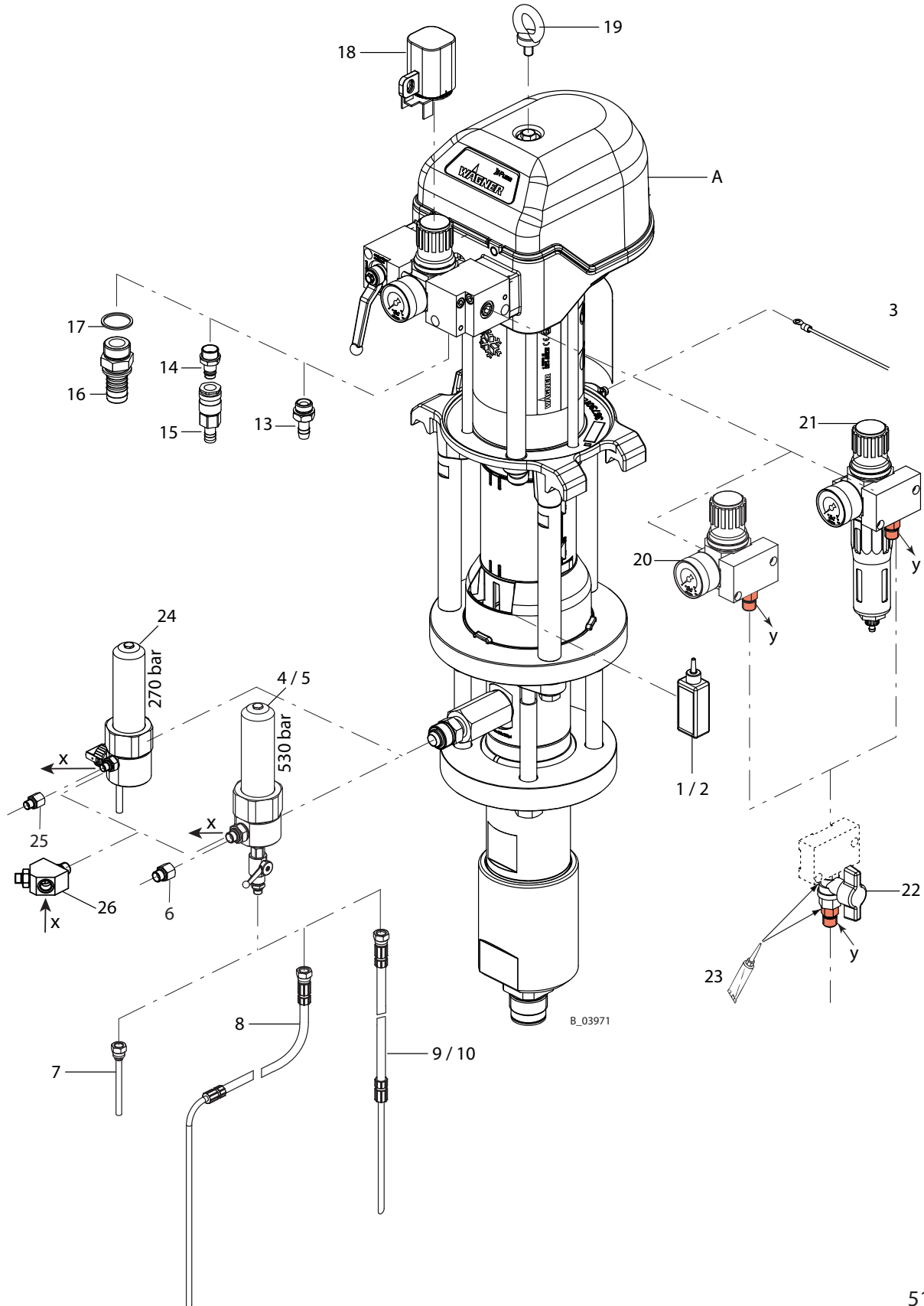

12.2 ACCESSORIES FOR PRODUCT INLET

Accessories list		PUMA 8-300	PUMA 3-600	LEOPARD 18-300	LEOPARD 8-600	JAGUAR 38-300	
Pos	K	Designation	Order No.	Order No.	Order No.	Order No.	
A		Piston pump PE/TG	2329527	2329531	2329497	2329533	2329509
A		Piston pump PE/T	2329529	-	2329499	-	2329507
1	◆	Suction hose DN25-SSt, complete	2324116				
2	◆	Suction hose DN38-G1/2"-CS, complete	2329592				
3		LP hose fitting DN25-M36-SSt	2325408				
4	◆	LP hose DN25-PN10-EPDM (per meter)	2323474				
5	◆	LP hose DN25-PN10-PA (per meter)	2323595				
6		Suction tube DN25-SSt, complete	2323239				
7		Suction elbow DN25-SSt	2324247				
8		Suction pipe DN25-200L-SSt, complete	2324238				
9		Bung adapter DN25-G2"	2315163				
10		Suction pipe DN25-30L-SSt, complete	2324241				
11	◆	Suction filter DN25-18mesh-SSt	2323325				
12	◆	Suction filter DN38-12.8mesh-SSt	2329596				
13		Fitting DF-MM-R1½"-M36-PN15-SSt	2329563				
14		Fitting DF-MM-R1½"-G1½"-PN15-SSt	2329073				
15		Anti-seize paste	9992609				

◆ = Wearing parts

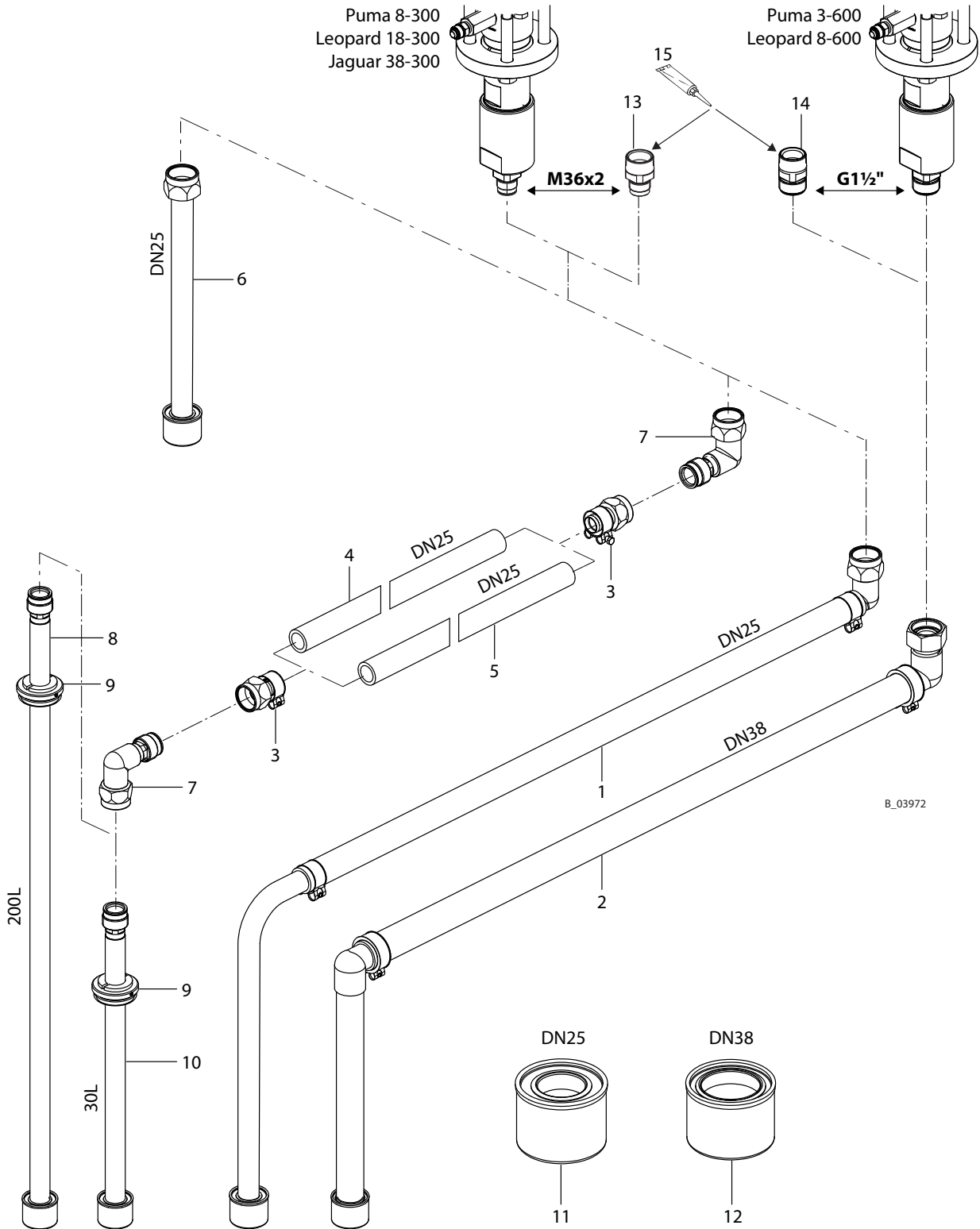

12.3 TROLLEY, RACK AND WALL BRACKET ACCESSORIES

Accessories list		PUMA 8-300	PUMA 3-600	LEOPARD 18-300	LEOPARD 8-600	JAGUAR 38-300	
Pos	K	Designation	Order No.	Order No.	Order No.	Order No.	
A		Piston pump PE/TG	2329527	2329531	2329497	2329533	2329509
A		Piston pump PE/T	2329529	-	2329499	-	2329507
1		Trolley 4", complete	2325901		--		
2		Trolley 6", complete	--	2325916		--	
3		Trolley PC, complete	--	2339705			
4		Wall mount 4", complete	2332143		--		
5		Wall mount 6", complete	--	2332145		--	
6		Wall mount 9", complete	--			369020	

◆ = Wearing parts

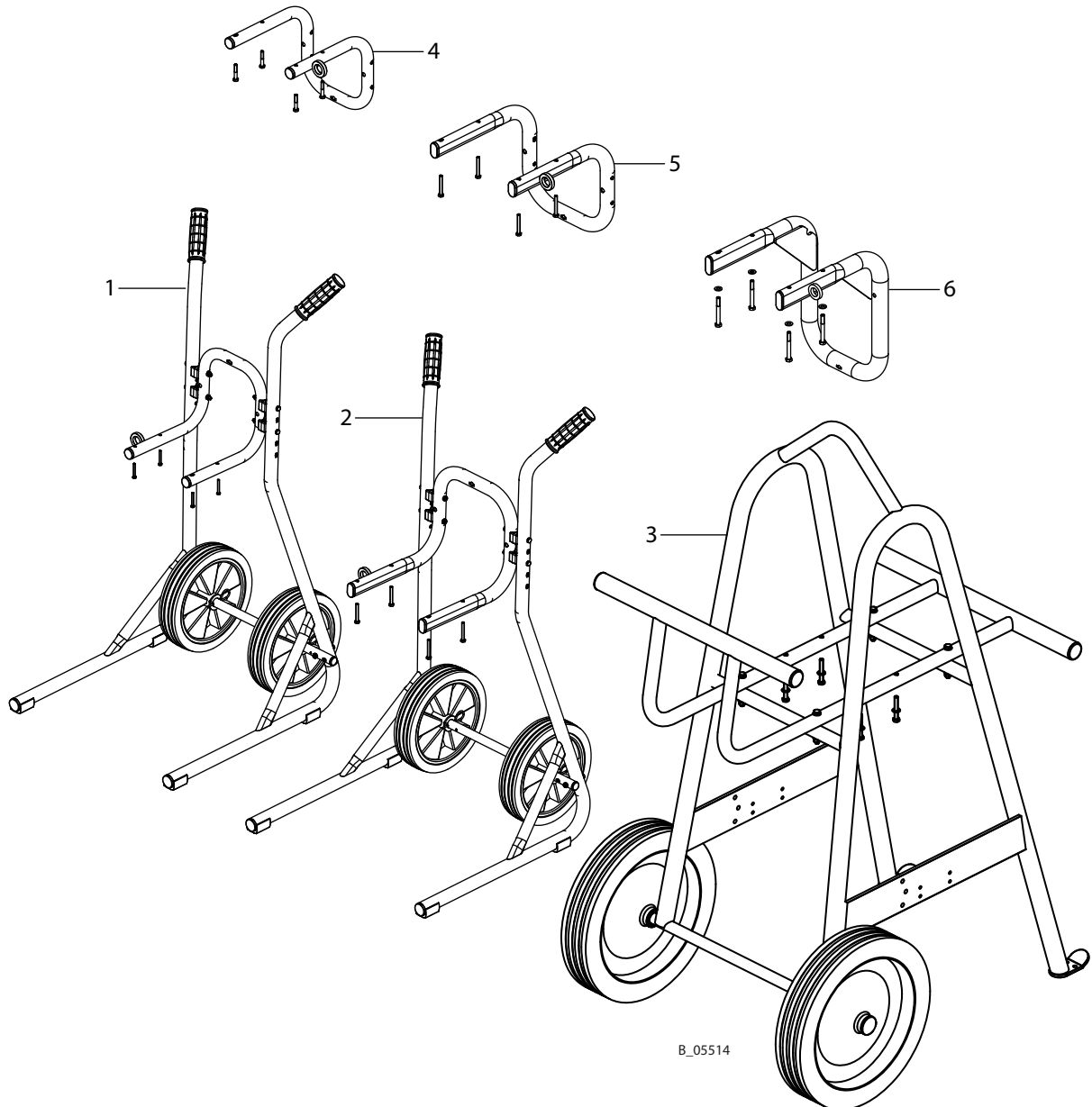

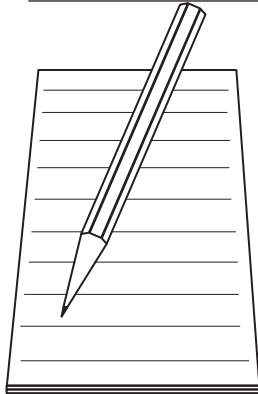



Lined writing area consisting of multiple horizontal lines for text entry.

13 SPARE PARTS

- Observe "Repair" chapter: Repair personnel and mounting materials.
- The service manuals are available separately. See Chapter 1.3.

	 DANGER
	<p>Incorrect maintenance/repair! Danger to life and equipment damage.</p> <ul style="list-style-type: none"> → Only a WAGNER service center or a suitably trained person may carry out repairs and replace parts. → Only repair and replace parts that are listed in the "Spare parts" chapter and that are assigned to the unit. → Before all work on the device and in the event of work interruptions: <ul style="list-style-type: none"> - Relieve pressure from spray guns and devices. - Secure spray guns against actuation. - Switch off the energy/compressed air supply. - Disconnect the control unit from the mains. → Observe the operating and service manual for all work.

13.1 HOW CAN SPARE PARTS BE ORDERED?

Always supply the following information to ensure delivery of the right spare part:

Order number, designation and quantity

The quantity need not be the same as the number given in the quantity column "**Stk**" on the list. This number merely indicates how many of the respective parts are used in each component.

The following information is also required to ensure smooth processing of your order:

- Address for the invoice
- Address for delivery
- Name of the person to be contacted in the event of any queries
- Type of delivery (normal mail, express delivery, air freight, courier, etc.)

Identification in spare parts lists.

Explanation of column "**K**" (labeling) in the following spare parts lists:

- ◆ Wearing parts

Note: These parts are not covered by warranty terms.

- Not part of standard equipment, available, however, as additional extra.

13.2 OVERVIEW OF THE COMPONENTS

Pos	Designation	PUMA		
		8-300 PE/TG	8-300 PE/T	3-600 PE/TG
		Order No.	Order No.	Order No.
1	Piston pump	2329527	2329529	2329531
2	Fluid section	2329660	2329662	2329679
3	Air motor	2329619		
4	Connection set for air motor - fluid section	2350031		
9	Grounding cable	236219		
10	Molykote® DX grease	9992616		
	Tightening torque for air motor/fluid section	50 Nm; 37 lbft		

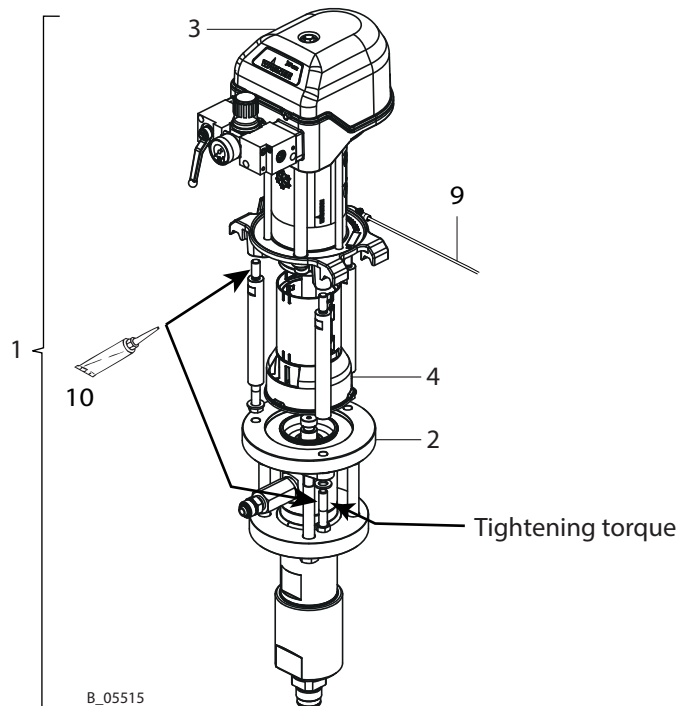

		LEOPARD		
		18-300 PE/TG	18-300 PE/T	8-600 PE/TG
Pos	Designation	Order No.	Order No.	Order No.
1	Piston pump	2329497	2329499	2329533
2	Fluid section	2329660	2329662	2329679
3	Air motor	2329623		
4	Connection set for air motor - fluid section	2350033		
9	Grounding cable, complete	236219		
10	Molykote® DX grease	9992616		
	Tightening torque, air motor/fluid section	50 Nm; 37 lbft		

		JAGUAR	
		38-300 PE/TG	38-300 PE/T
Pos	Designation	Order No.	Order No.
1	Piston pump	2329509	2329507
2	Fluid section	2329660	2329662
3	Air motor	2329625	
4	Connection set for air motor - fluid section	2350033	
9	Grounding cable, complete	236219	
10	Molykote® DX grease	9992616	
	Tightening torque, air motor/fluid section	50 Nm; 37 lbft	

13.3 AIR MOTORS

13.3.1 PUMA AND LEOPARD AIR MOTORS

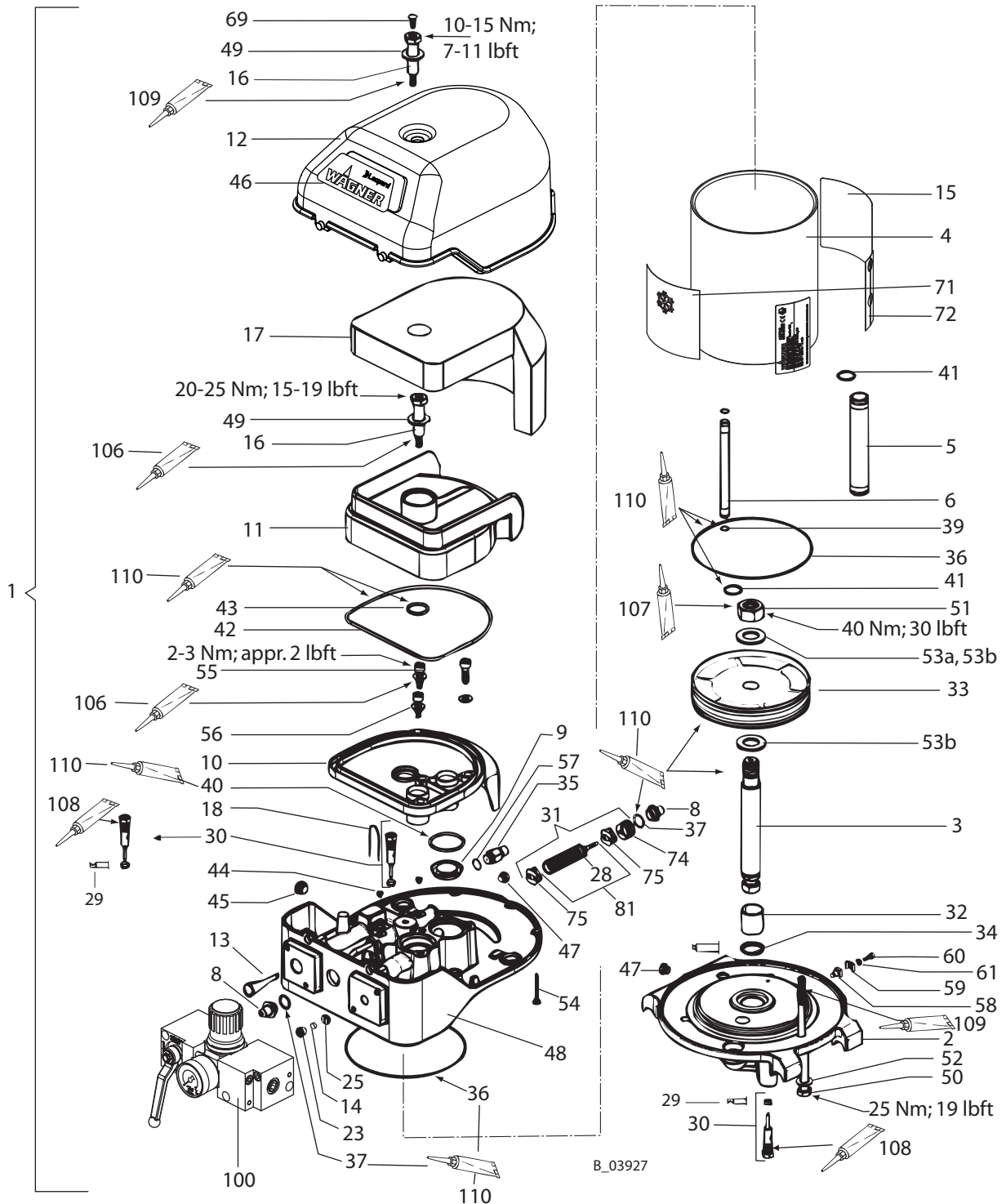

Pressure regulator (pos. 100) For details, see Chapter 13.3.2 / 11.3.3.

Do not dismantle the piston (pos. 81).



DANGER
Incorrect maintenance/repair!

Danger to life and equipment damage.

- Only a WAGNER service center or a suitably trained person may carry out repairs and replace parts.
- Only repair and replace parts that are listed in the "Spare parts" chapter and that are assigned to the unit.
- Before all work on the device and in the event of work interruptions:
 - Relieve pressure from spray guns and devices.
 - Secure spray guns against actuation.
 - Switch off the energy/compressed air supply.
 - Disconnect the control unit from the mains.
- Observe the operating and service manual for all work.

Spare parts list air motor		PUMA		LEOPARD		
		Ø 100 mm / stroke 150 mm Ø 4 / stroke 6 inches		Ø 150 mm / stroke 150 mm Ø 6 / stroke 6 inches		
Pos	K	Designation	Stk	Order No.	Stk	Order No.
1		Air motor	1	2329619	1	2329623
2		Flange	1	367316	1	368316
3		Piston rod	1	367402	1	368402
4		Cylinder pipe	1	367403	1	368403
5		Compressed air pipe	1	367404	1	368404
6		Control air pipe	1	367405	1	367405
8		Sealing plug	2	367307	2	367307
9	◆ ★	Outlet seal	2	L414.06C	2	L423.06
10		Connecting part	1	367309	1	368309
11		Silencer	1	367310	1	368310
12		Hood	1	367311	1	368311
13	◆ ★	Compressed air filter	1	367313	1	367313
14	◆ ★	Control air filter	1	367314	1	367314
15		Fluid warning label	1	2332082	1	2332082
16		Shoulder screw	2	367318	2	368324
17	◆	Sound deadening pad	1	367319	1	368319
18		Cotter pin	2	367320	2	368320
23		Filter holder	1	367324	1	367324
25		Throttle		–	1	367325
28	◆	O-ring	6	9971123	6	9974142
29	◆	Rod seal	2	9974217	2	9974217
30	◆	Pilot valve	2	369290	2	369290
31	◆	Spool and sleeve assembly	1	9943080	1	9943081
32	◆	Permaglide bushing	1	9962018	1	9962019
33	◆	Piston	1	9998661	1	9998662

◆ = Wearing parts

★ = Included in service set

Spare parts list air motor			PUMA		LEOPARD	
			Ø 100 mm / stroke 150 mm Ø 4 / stroke 6 inches		Ø 150 mm / stroke 150 mm Ø 6 / stroke 6 inches	
Pos	K	Designation	Stk	Order No.	Stk	Order No.
34	◆ ★	Seal wiper ring	1	9974090	1	9974091
35		Safety valve	1	368288	1	368287
36	◆ ★	O-ring	2	9974084	2	9974087
37	◆ ★	O-ring	2	9974085	2	9974085
39	◆ ★	O-ring	2	9974089	2	9974089
40	◆ ★	O-ring	2	9974095	2	9974096
41	◆ ★	O-ring	2	9971448	2	9971137
42	◆ ★	O-ring	1	9974097	1	9974100
43	◆ ★	O-ring	1	9974098	1	9974101
44		Threaded plug	1	9998674	2	9998674
45		Threaded plug	1	9998274	2	9998274
46		WAGNER label	1	2330370	1	2330371
47		Threaded plug	2	9998675	2	9998675
48		Control housing	1	367315	1	368315
49		Washer	2	9925033	2	9925026
50		Hexagon screw	3	9907121	3	9907137
51		Hexagon nut	1	9910101	1	9910605
52		Washer	3	9920106	3	9920106
53a		Washer	1	9920107		
53b		Washer			2	9920110
54		SFS screw	2	9907126	3	9907125
55		Socket cap screw	3	9900325	3	9900313
56		Washer	3	9920103	3	9920102
57	◆ ★	Sealing ring	1	9970149	1	9970149
58		Base	1	9952668	1	9952668
59		Clamping bracket	1	9952667	1	9952667
60		Socket cap screw	1	9900701	1	9900701
61		Spring washer	1	9921505	1	9921505
69		Drive fastener	1	9998718	1	9998718
71		IceBreaker label	1	2330382	1	2330382
72		Warning label	1	2332077	1	2332077
74	◆	Detent element, complete ISO 1/2	1	368038	1	368038
75	◆	Damper ISO 1/2	2	368313	2	368313
81	◆	Spool & sleeve assembly ISO1 or ISO2	1	9943097	1	9943098
100		Pressure regulator unit, complete (incl. pos. 62)	1	2328606	1	2328606
106		Loctite® 222 50ml; 50cc	1	9992590	1	9992590
107		Loctite® 243, 50ml; 50cc	1	9992511	1	9992511
108		Loctite® 542, 50ml; 50cc	1	9992831	1	9992831
109		Molykote® DX grease	1	9992616	1	9992616
110		Mobilux® EP 2 grease	1	9998808	1	9998808
		Service set	1	367995	1	368995

◆ = Wearing parts

★ = Included in service set

13.3.2 PUMA AIR MOTOR REGULATOR

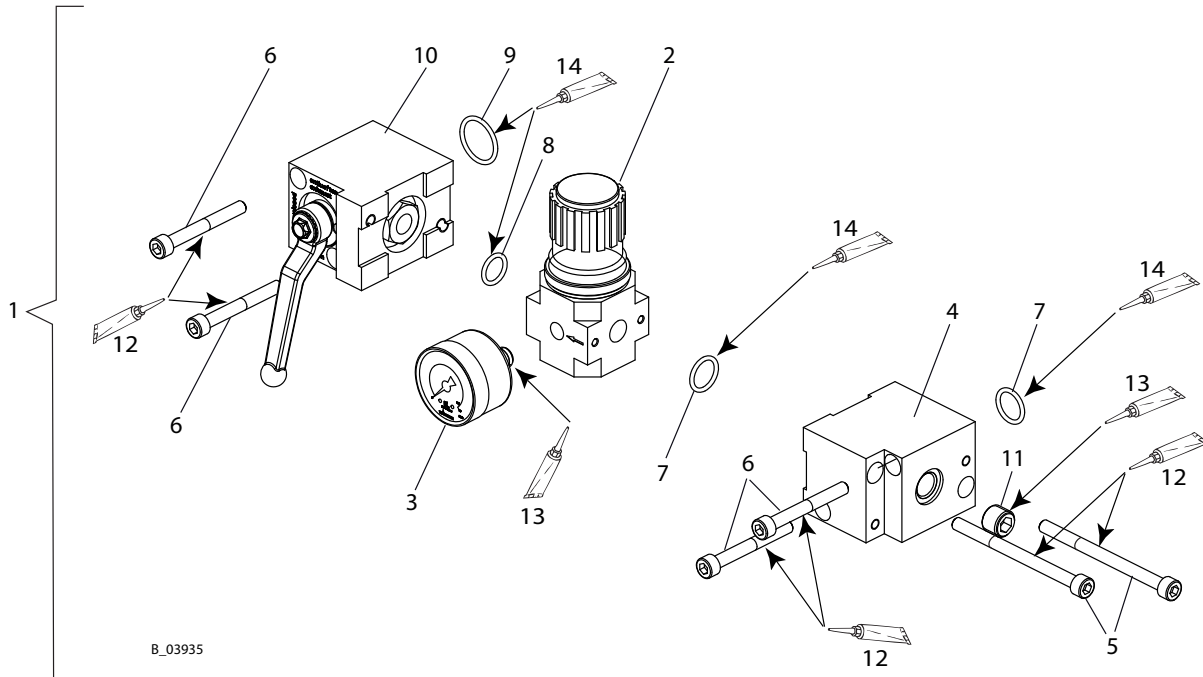

Pos 3: Screw in the pressure gauge until the white sealing ring is completely in the filter control valve. Thereafter continue turning the pressure gauge only to align the display scale.

Air motor regulator spare parts list Puma			PUMA	
			Ø 100 mm / stroke 150 mm	
			Ø 4 inches / stroke 6 inches	
Pos	K	Designation	Stk	Order No.
1		Pressure regulator unit, 4", complete	1	2328606
2	◆	Pressure regulator valve 4"	1	2309972
3	◆	Pressure gauge 0-10 bar (d40)	1	9998677
4		Distribution piece 4"	1	2309744
5		Hexagon socket cylinder head screw	2	9907039
6		Hexagon socket cylinder head screw	4	9900316
7	◆	O-ring	2	9974166
8	◆	O-ring	1	9971313
9	◆	O-ring	1	9971137
10	◆	Edge ball valve 4"	1	2310635
11		Screw plug	1	104376
12		Molykote® DX grease	1	9992616
13		Loctite® 542, 50ml; 50cc	1	9992831
14		Mobilux® EP 2 grease	1	9998808

◆ = Wearing parts

★ = Included in service set

13.3.3 LEOPARD AIR MOTOR REGULATOR

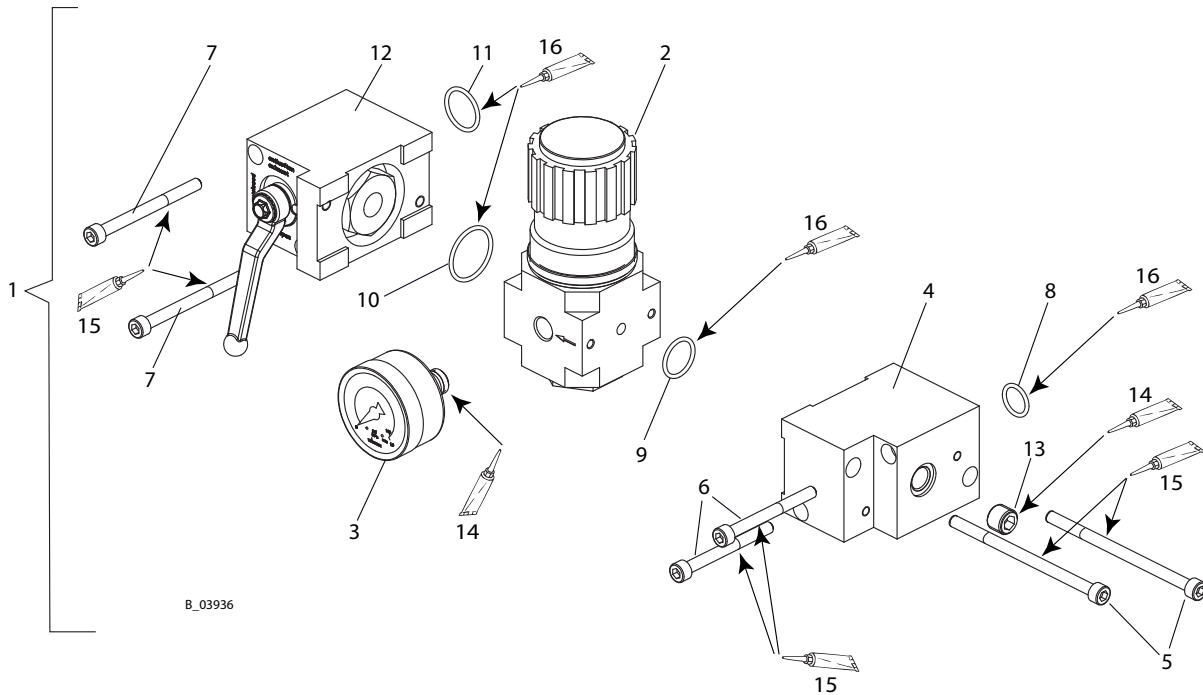



Pos 3: Screw in the pressure gauge until the white sealing ring is completely in the filter control valve. Thereafter continue turning the pressure gauge only to align the display scale.

Air motor regulator spare parts list Leopard				LEOPARD	
				Ø 150 mm / stroke 150 mm Ø 6 inches / stroke 6 inches	
Pos	K	Designation	Stk	Order No.	
1		Pressure regulator unit, 6", complete	1	2328607	
2	◆	Pressure regulator valve 6"	1	2309973	
3	◆	Pressure gauge 0-10 bar (d50)	1	9998725	
4		Distribution piece 6"	1	2309783	
5		Hexagon socket cylinder head screw	2	3050699	
6		Hexagon socket cylinder head screw	2	9907024	
7		Hexagon socket cylinder head screw	2	9906020	
8	◆	O-ring	1	9974166	
9		O-ring	1	9971018	
10		O-ring	1	3105540	
11	◆	O-ring	1	9971137	
12	◆	Edge ball valve 6"	1	2310636	
13		Screw plug	1	104376	
14		Loctite® 542	1	9992831	
15		Molykote® DX grease	1	9992616	
16		Mobilux® EP 2 grease	1	9998808	

◆ = Wearing parts
★ = Included in service set

13.3.4 JAGUAR AIR MOTOR

	 DANGER
	<p>Incorrect maintenance/repair! Danger to life and equipment damage.</p> <ul style="list-style-type: none"> → Only a WAGNER service center or a suitably trained person may carry out repairs and replace parts. → Only repair and replace parts that are listed in the "Spare parts" chapter and that are assigned to the unit. → Before all work on the device and in the event of work interruptions: <ul style="list-style-type: none"> - Relieve pressure from spray guns and devices. - Secure spray guns against actuation. - Switch off the energy/compressed air supply. - Disconnect the control unit from the mains. → Observe the operating and service manual for all work.

Jaguar air motor spare parts list

JAGUAR
 ø 220 mm / stroke 150 mm
 ø 8.7 inches / stroke 6 inches

Pos	K	Stk	Designation	Order No.
1			Air motor	2329625
2		1	Flange	369316
3	◆	1	Piston rod	368402
4		1	Cylinder pipe	369403
5		2	Compressed air pipe	368404
6		1	Control air pipe	367405
8		1	Sealing plug	369307
9	◆ ★	2	Outlet seal	369312
10		1	Connecting part	369309
11		1	Silencer	369310
12		1	Hood	369905
13	◆ ★	1	Compressed air filter	369313
14	◆ ★	1	Control air filter	367314
15		1	Fluid warning label	2332082
16		1	Shoulder screw	369318
17	◆	1	Sound deadening pad	369906
18		2	Cotter pin	369320
23		1	Filter holder	367324
25		1	Throttle	367325
28	◆	6	O-ring	9974143
29	◆	2	Rod seal	9974217
30	◆	2	Pilot valve	369290

◆ = Wearing parts

★ = Included in service set

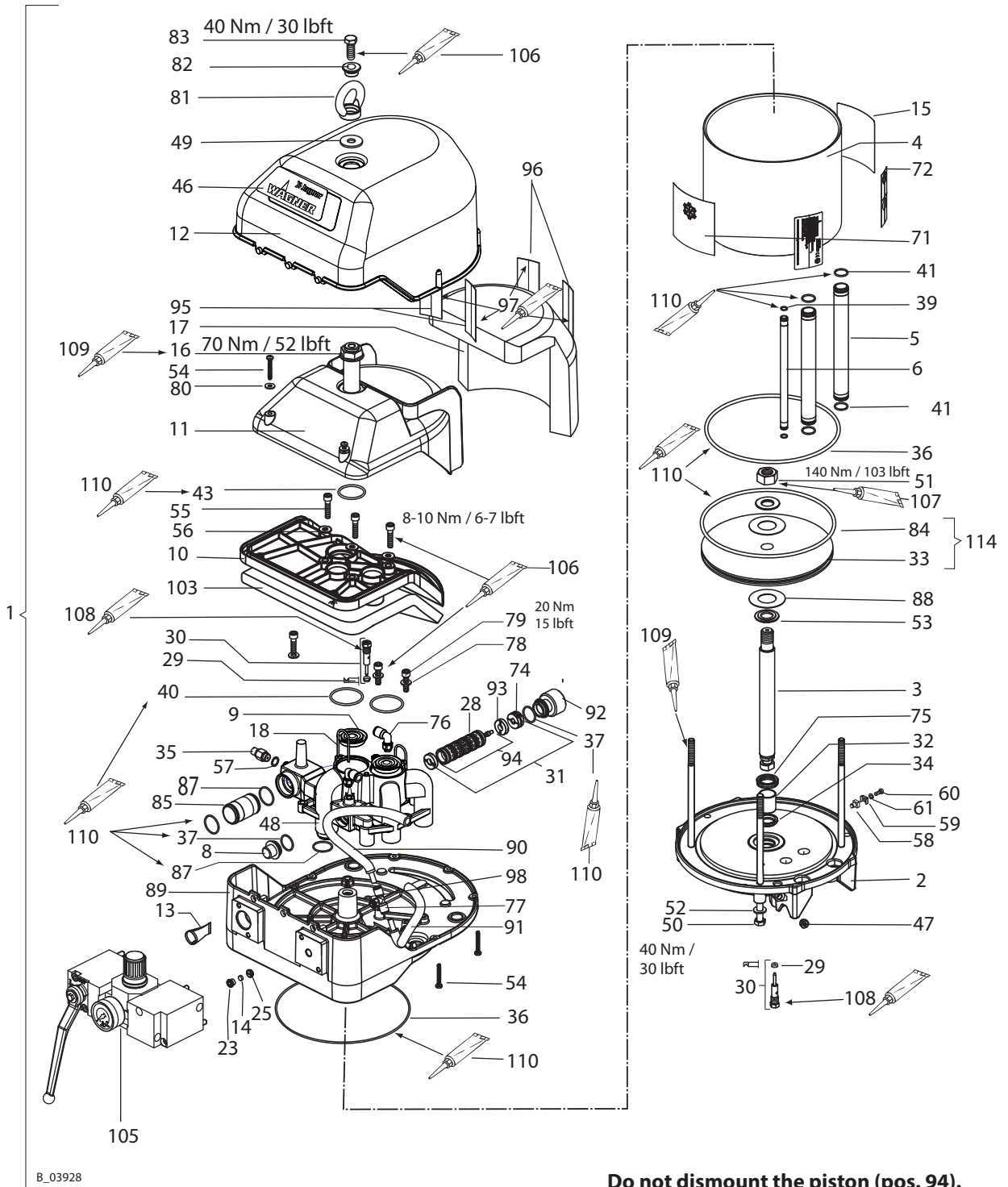

Do not dismantle the piston (pos. 94).

Pressure regulator (pos. 105) details see Chapter 13.3.5.

Jaguar air motor spare parts list

JAGUAR
 ø 220 mm / stroke 150 mm
 ø 8.7 inches / stroke 6 inches

Pos	K	Stk	Designation	Order No.
31	◆	1	Spool and sleeve assembly	369907
32	◆	1	Permaglide bushing	9962019
33		1	Piston 9	369385
34	◆ ★	1	Seal wiper ring	9974125
35		1	Safety valve 7.5 bar	368286
36	◆ ★	2	O-ring	9974133
37	◆ ★	2	O-ring	9971056
39	◆ ★	2	O-ring	9974089
40	◆ ★	2	O-ring	9974132
41	◆ ★	4	O-ring	9971137
43	◆ ★	1	O-ring	9974165
46		1	WAGNER label	2330372
47		2	Threaded plug	9998675
48		1	Control housing	369315
49		1	Washer	9925034
50		4	Hexagon screw	9907137
51		1	Hexagon nut	9910605
52		4	Washer	9920106
53		2	Washer	369303
54		7	SFS screw	9907125
55		3	Socket cap screw	9900314
56		3	Washer	9925029
57	◆ ★	1	Sealing ring	9970149
58		1	Base	9952668
59		1	Clamping bracket	9952667
60		1	Socket cap screw	9900701
61		1	Spring washer	9921505
71		1	IceBreaker label	2330382
72		1	Warning label	2332077
74	◆	1	Detent body	369027
75		1	Rod seal profile E5	9974124
76		2	Elbow screw-in connection	9992757
77		1	Screw connector T	9992758
78		4	Washer	9920102
79		4	Socket cap screw	9900313
80		2	Washer	9925031
81		1	Lifting eye nut	369325

◆ = Wearing parts

★ = Included in service set

Jaguar air motor spare parts list			JAGUAR ø 220 mm / stroke 150 mm ø 8.7 inches / stroke 6 inches	
Pos	K	Stk	Designation	Order No.
82		1	Shoulder ring	369324
83		1	Hexagon screw	9900150
84	◆ ★	1	O-ring	9974262
85		1	Air pipe	369306
87	◆	3	O-ring	9971004
88		2	Damping washer	369304
89		1	Control flange	369317
90		1	Air hose back	369026
91		1	Air hose front	369025
92		1	Lock space 9	369326
93	◆	2	Damper ISO3	369329
94	◆	1	Spool & sleeve assembly ISO3	9943131
95	◆	1	Velcro fastener adhesive part	9999151
96	◆	1	Velcro fastener coating part	9999152
97		1	Adhesive	9992816
98	◆	1	Viton B O-ring	9971372
103	◆	1	Sound absorbing mat 9/12"	369330
105		1	Pressure regulator unit 9, complete	2328609
106		1	Loctite 222 50 ml; 50 cc	9992590
107		1	Loctite 243 50 ml; 50 cc	9992511
108		1	Loctite 542 50 ml; 50 cc	9992831
109		1	Anti-seize paste	9992616
110		1	Mobilux® EP 2 grease	9998808
114		1	Piston 9 with SOFT O-ring	369971
		1	Service set	369987

◆ = Wearing parts

★ = Included in service set

13.3.5 JAGUAR AIR MOTOR REGULATOR

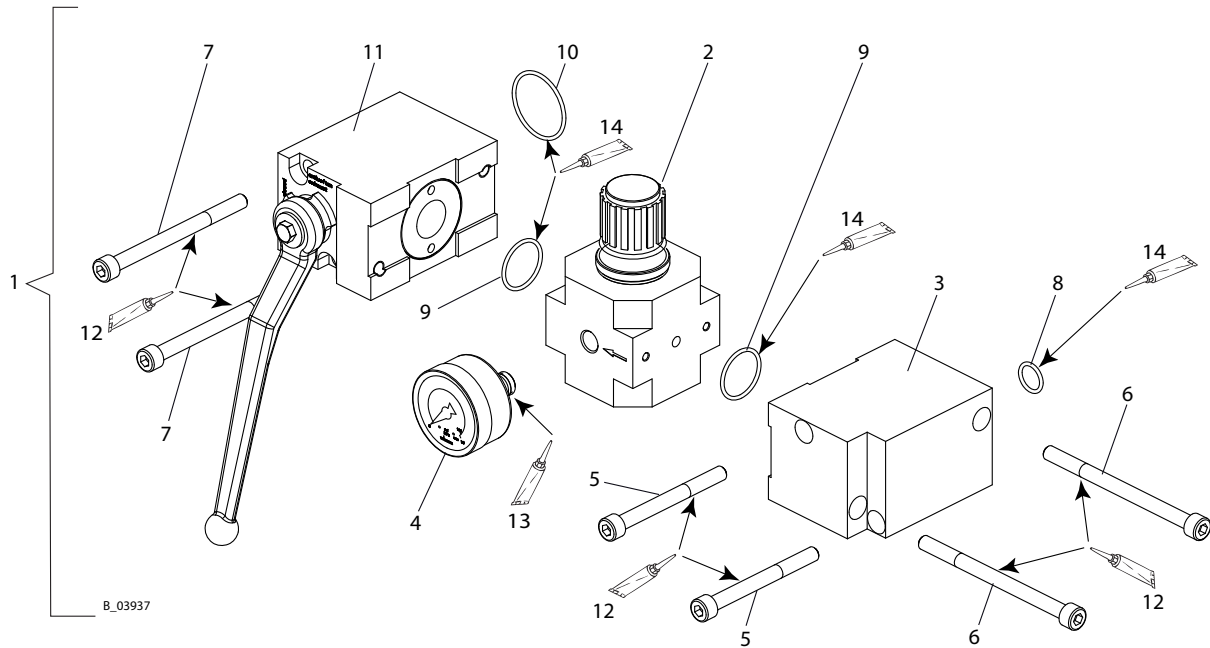

Pos 3: Screw in the pressure gauge until the white sealing ring is completely in the filter control valve. Thereafter continue turning the pressure gauge only to align the display scale.

Air motor regulator spare parts list Jaguar

JAGUAR
 ø 220 mm / stroke 150 mm
 ø 8.7 inches / stroke 6 inches

Pos	K	Stk	Designation	Order No.
1		1	Pressure regulator unit, 9", complete	2328609
2	◆	1	Pressure regulator valve 9"	2309974
3		1	Distribution piece 9"	2309963
4	◆	1	Pressure gauge 0-10 bar (d50)	9998725
5		2	Hexagon socket cylinder head screw	9900360
6		2	Hexagon socket cylinder head screw	9907087
7		2	Hexagon socket cylinder head screw	9900356
8	◆	1	O-ring	9974166
9		2	O-ring	3105540
10	◆	1	O-ring	9971405
11	◆	1	Edge ball valve 9"	2310637
12		1	Molykote® DX grease	9992616
13		1	Loctite® 542, 50ml; 50cc	9992831
14		1	Mobilux® EP 2 grease	9998808

◆ = Wearing part

★ = Included in service set

13.4. CONNECTION SETS

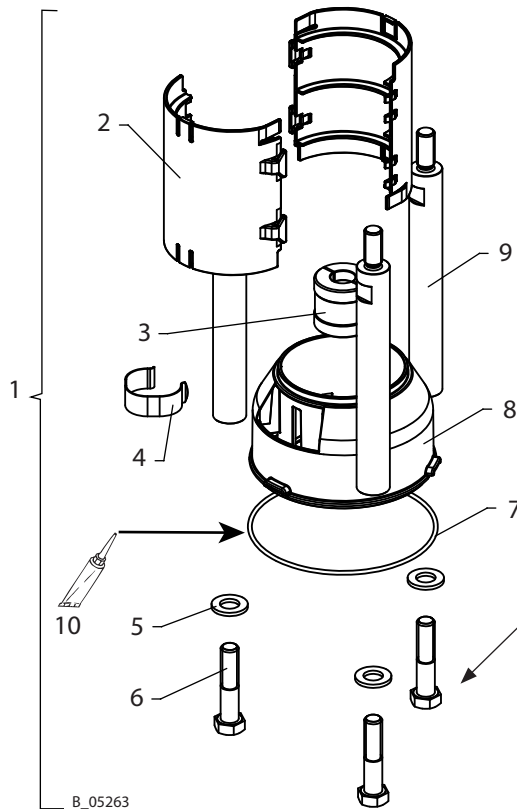

50 Nm; 37 lbft

Assembly with air motor and fluid section: see Chapter 13.2

Spare parts list for connection sets



Puma 8-300	Leopard 18-300	
	Leopard 8-600	
Puma 3-600	Jaguar 38-300	
	Connection set	
	LM-FS 3	LM-FS 5
	Order No.	Order No.
1	2350031	2350033
2	368532	
3	367579	368529
4	367530	368530
5	9920107	
6	9900157	
7	9974116	
8	368531	
9	368533	
10	9998808	

Pos	K	Stk	Designation
1		1	Connection set LM-FS ...
2		2	Coupling cover stroke 150
3		1	Coupling
4		1	Spring
5		3	Washer, A12, DIN 125-1
6		3	Hexagon screws
7	◆ ★	1	O-ring
8		1	Separating oil cup stroke 150
9		3	Threaded bolt M12x169
10		1	Mobilux® EP 2 grease

◆ = Wearing parts

★ = Included in the service set of the fluid section PE/TG or PE/L (see Chapter 13.5).

13.5 FLUID SECTIONS**13.5.1 FLUID SECTION 300 CM³**

	 WARNING
	<p>Incorrect maintenance/repair! Risk of injury and damage to the device.</p> <p>→ Repairs and part replacement may only be carried out by specially trained staff or a WAGNER service center.</p> <p>→ Before all work on the device and in the event of work interruptions:</p> <ul style="list-style-type: none"> - Switch off the energy/compressed air supply. - Relieve the pressure from the spray gun and device. - Secure the spray gun against actuation. <p>→ Observe the operating and service manual for all work.</p>

Fluid sections spare parts list				300 cm ³ PE/TG	300 cm ³ PE/T
Pos	K	Stk	Designation	Order No.	Order No.
1			Fluid section	2329660	2329662
2		1	Pipe		369502
3		1	Cylinder		369503
4		1	Inlet housing		369504
5	◆	1	Piston		369505
6		1	Valve screw		369506
7	◆ ★	1	Ball guide, inlet		369507
8		1	Connecting flange		369501
9	◆	1	Valve seat inlet (carbide)		369509
10	◆	1	Valve seat outlet (carbide)		369510
11		1	Snap ring flange		369511
12		2	Snap ring half		369512
13		1	Securing ring		369513
16		1	Support ring		369516
17		1	Pressure ring		368519
18		1	Support ring		369518
19		1	Pressure ring		369519
20	◆ ★	2	Sealing collar TG	368522	/
20	◆ ★	2	Sealing collar T	/	368900
21	◆ ★	3	Sealing collar PE	368523	368523
22	◆ ★	2	Sealing collar TG	369522	/
22	◆ ★	2	Sealing collar T	/	369900

◆ = Wearing part

★ = Included in service set

● = Not part of the standard equipment but available as a special accessory.

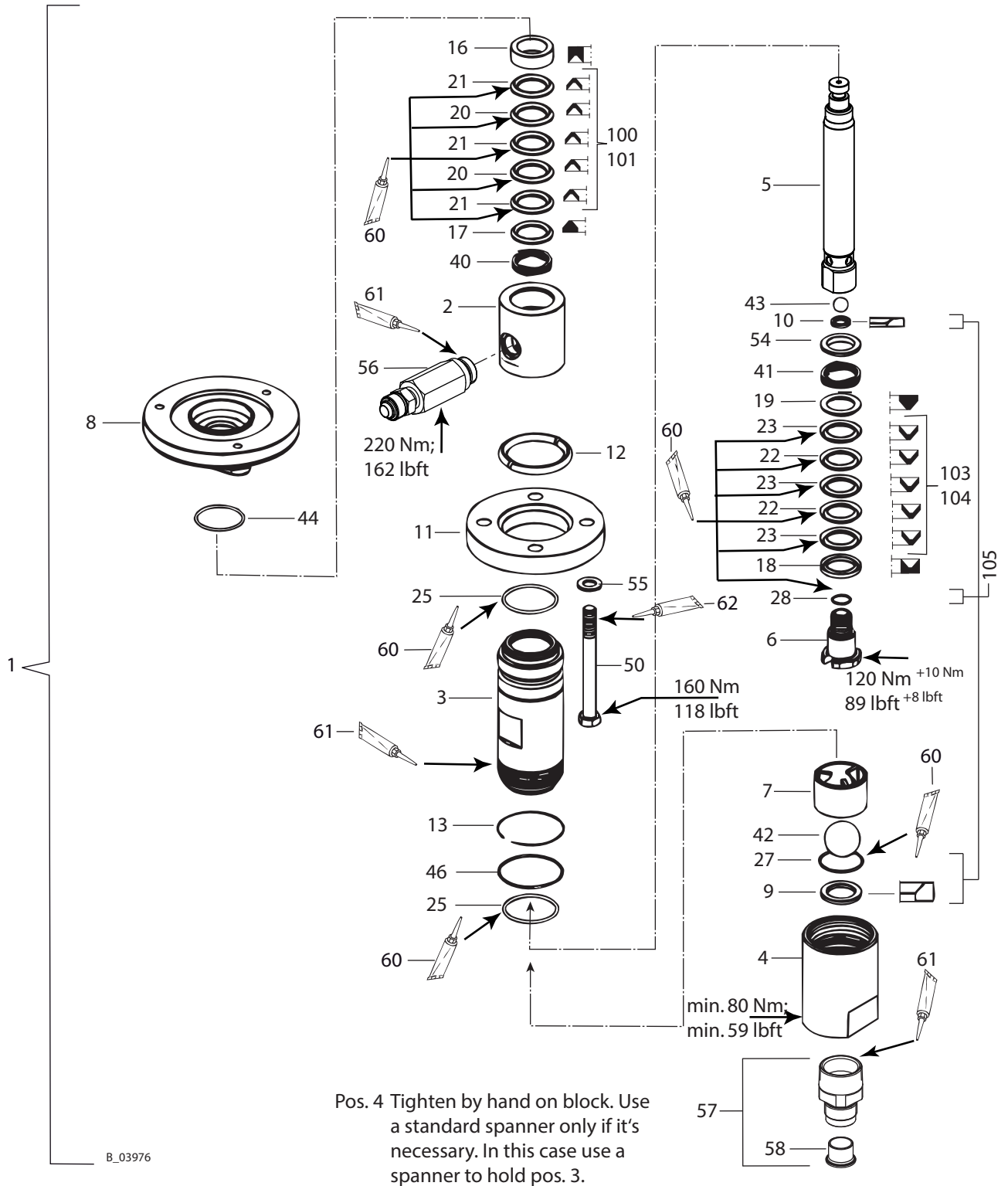

Pos. 4 Tighten by hand on block. Use a standard spanner only if it's necessary. In this case use a spanner to hold pos. 3.

B_03976

Fluid sections spare parts list				300 cm³ PE/TG	300 cm³ PE/T
Pos	K	Stk	Designation	Order No.	Order No.
23	◆ ★	3	Sealing collar PE	369523	369523
25	◆ ★	2	O-ring	369525	
27	◆ ★	1	O-ring	369527	
28	◆ ★	1	O-ring	369528	
40	◆ ★	1	Spirawave, crest-to-crest	9998671	
41	◆ ★	1	Spirawave, crest-to-crest	9998671	
42	◆ ★	1	Ball (large)	9943086	
43	◆ ★	1	Ball (small)	9941505	
44	◆ ★	1	O-ring	9974117	
46	◆ ★	1	O-ring	9974118	
50		4	Hexagon screw	9907149	
54		1	Shoulder ring	369514	
55		4	Washer	9925011	
56		1	Rotary connection G3/4"	2329923	
57		1	Fitting DF-MM-R1½"-M36-PN15-SSt	2329563	
58		1	Sealing sleeve	2329898	
60			Mobilux® EP 2 grease	9998808	
61		1	Anti-sieze paste, 100 g	9992609	
62			Molykote® DX grease	9992616	

Packing, upper:

100	◆	1	Packing PE/TG, complete	368991	
101	◆	1	Packing PE/T, complete		368992

Packing, lower:

103	◆	1	Packing PE/TG, complete	369991	
104	◆	1	Packing PE/T, complete		369992

Valve seat, stainless steel:

105	◆ ●		Valve seat set 300, in stainless steel version, consisting of: pos. Pos 9, 10, 27, 28	2331586	
-----	-----	--	---	---------	--

Service sets:

			Service set PE/TG	369990	
			Service set PE/T		369964

◆ = Wearing part

★ = Included in service set

● = Not part of the standard equipment but available as a special accessory.

13.5.2 FLUID SECTION 600 CM³

	 WARNING
	<p>Incorrect maintenance/repair! Risk of injury and damage to the device.</p> <p>→ Repairs and part replacement may only be carried out by specially trained staff or a WAGNER service center.</p> <p>→ Before all work on the device and in the event of work interruptions:</p> <ul style="list-style-type: none"> - Switch off the energy/compressed air supply. - Relieve the pressure from the spray gun and device. - Secure the spray gun against actuation. <p>→ Observe the operating and service manual for all work.</p>

Fluid sections spare parts list				600 cm ³ PE/TG
Pos	K	Stk	Designation	Order No.
1			Fluid section	2329679
2		1	Pipe	369552
3		1	Cylinder	369553
4		1	Inlet housing	369554
5	◆	1	Piston	369555
6		1	Valve screw	369556
7	◆ ★	1	Ball guide, inlet	369507
8		1	Valve screw inlet	369558
9	◆	1	Valve seat inlet (carbide)	369509
10	◆	1	Valve seat outlet (carbide)	368509
11		1	Connecting flange	369551
16		1	Support ring	369566
17		1	Pressure ring	369567
18		1	Support ring	369568
19		1	Pressure ring	369569
20	◆ ★	2	Sealing collar TG	369570
21	◆ ★	3	Sealing collar PE	369571
22	◆ ★	2	Sealing collar TG	369572
23	◆ ★	3	Sealing collar PE	369573
25	◆ ★	2	O-ring	369575
27	◆ ★	1	O-ring	369527
28	◆ ★	1	O-ring	9971464
40	◆ ★	1	Spirawave, crest-to-crest	9998834
41	◆ ★	1	Spirawave, crest-to-crest	9998834
42	◆ ★	1	Ball (large)	9943086

◆ = Wearing parts

★ = Included in service set

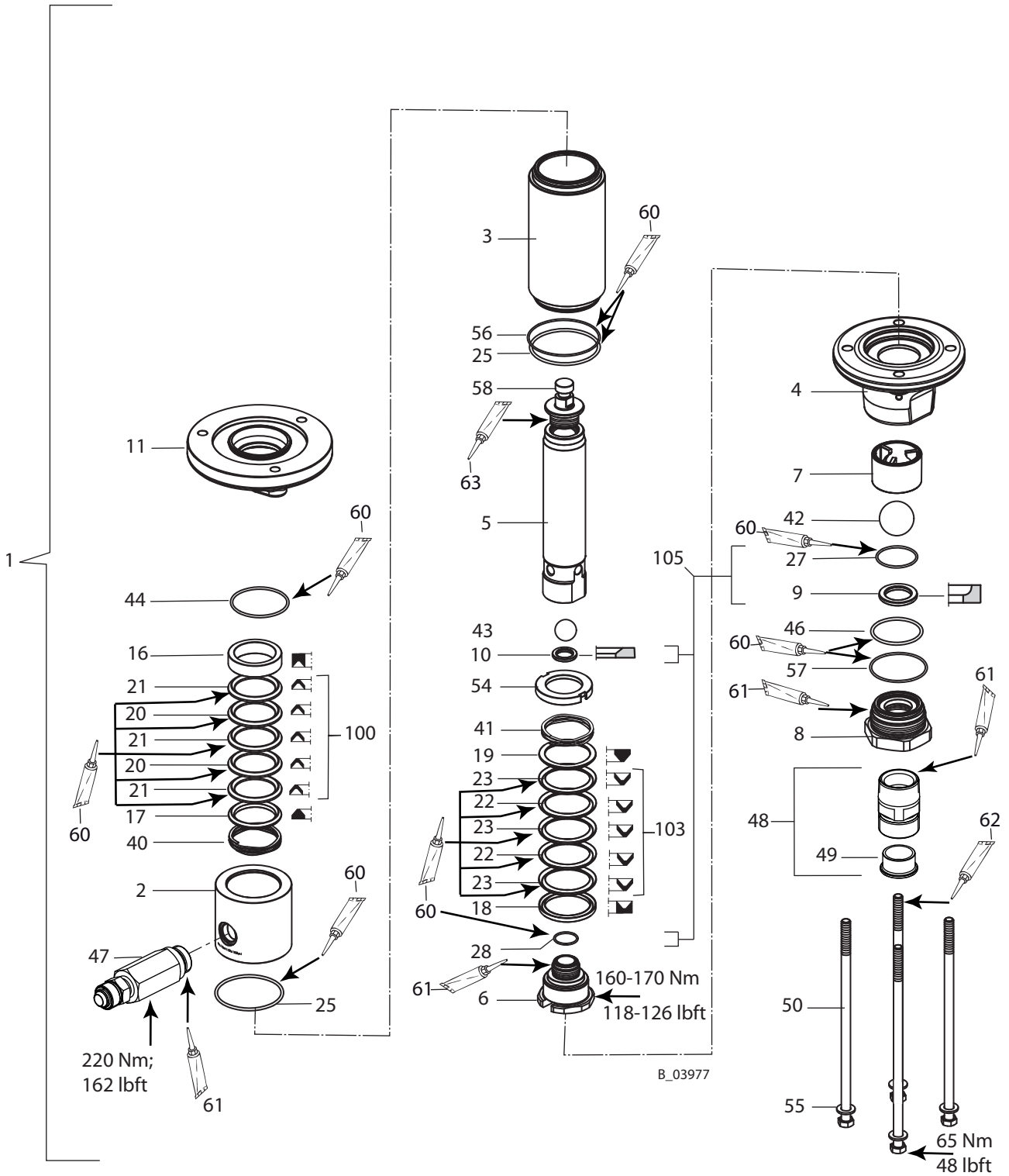

Fluid sections spare parts list				600 cm³ PE/TG
Pos	K	Stk	Designation	Order No.
43	◆ ★	1	Ball (small)	9943082
44	◆ ★	1	O-ring	9974123
46	◆ ★	1	O-ring	369525
47		1	Rotary connection G3/4"	2329923
48		1	Fitting DF-MM-R1½"-G1½"-PN15-SSt	2329073
49		1	Sealing sleeve	2329072
50		4	Hexagon screw	9907147
54		1	Shoulder ring	369564
55		4	Washer	9920107
56	◆ ★	1	O-ring	9974146
57	◆ ★	1	O-ring	9974145
58		1	Coupling peg 600	369562
60		1	Mobilux® EP 2 grease	9998808
61		1	Anti-sieze paste, 100 g	9992609
62		1	Molykote® DX grease	9992616
63		1	Loctite® 270, 50ml; 50cc	9992528
Packing, upper:				
100	◆	1	Packing PE/TG, complete	369994
Packing, lower:				
103	◆	1	Packing PE/TG, complete	369997
Valve seat, stainless steel:				
105	◆ ●		Valve seat set 600, in stainless steel version, consisting of: pos. Pos 9, 10, 27, 28	2331587
Service set:				
			Service set PE/TG	369989

◆ = Wearing parts

★ = Included in service set

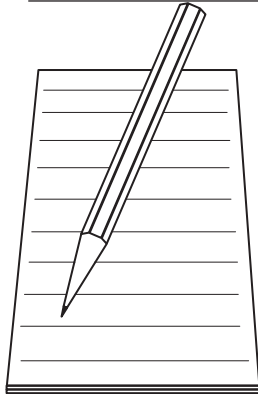

Five horizontal lines for writing, located to the right of the notepad illustration.

Twenty horizontal lines for writing, filling the lower two-thirds of the page.

13.6 HIGH-PRESSURE FILTER 270 BAR; 3916 PSI

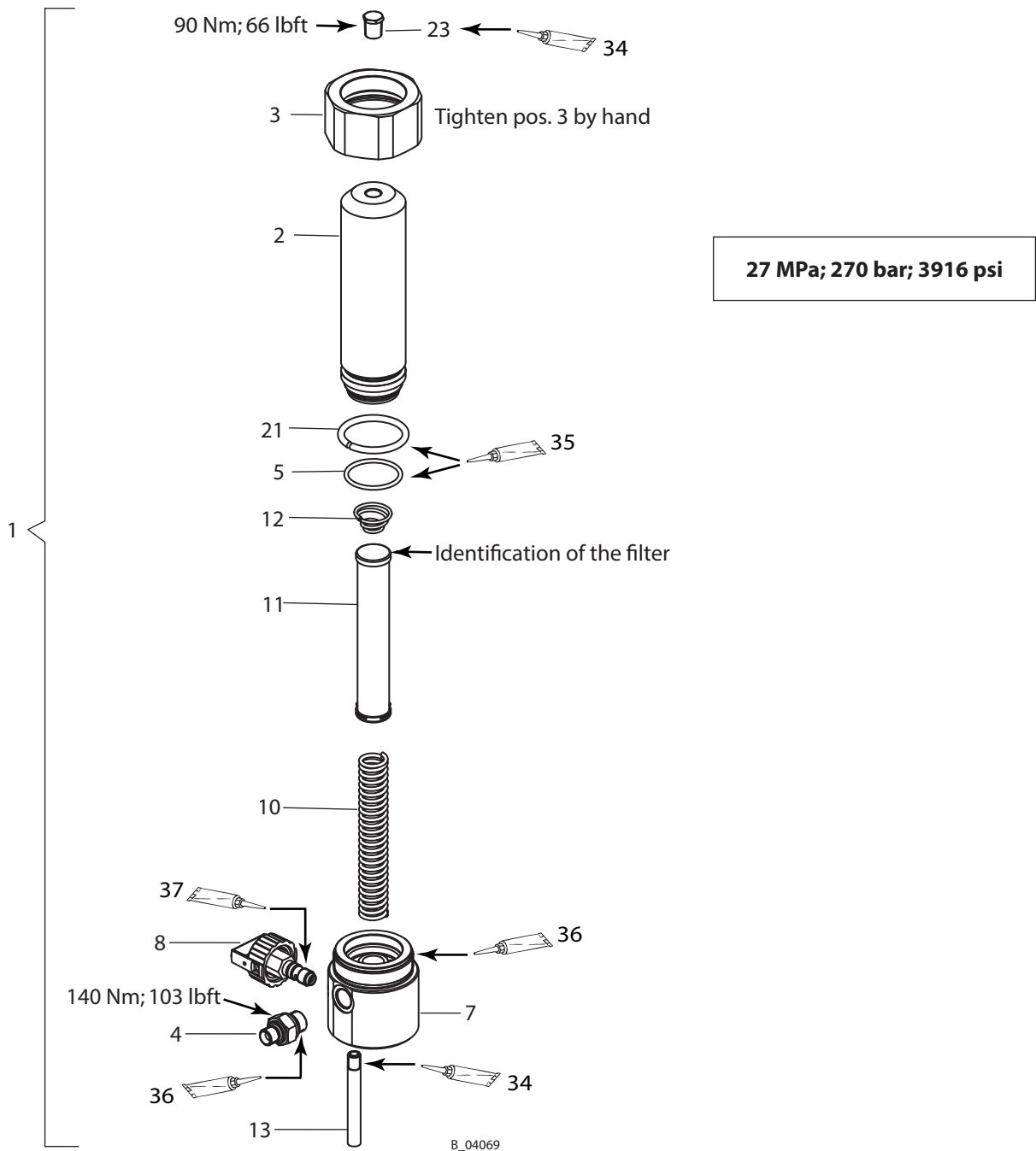

Spare parts list for high-pressure filter 270

				Ball valve version in:	Stainless steel
Pos	K	Stk	Designation	Order No.	
1		1	HP filter DN10-PN270 SSt, complete	2329024	
2		1	Filter housing	2324542	
3		1	Union nut	2324543	
4		1	Reducing double fitting with 2x60°	2325826	
5	◆	1	O-ring	9955863	
7		1	Distribution housing	2324544	
8	◆	1	Relief valve	169248	
10		1	Filter support	9894245	
11		1	Filter cartridge *		
	◆ ●		* Filter sieve, 200 mesh per inch (fine)	295721	
	◆		* Filter sieve, 100 meshes per inch (medium), mesh width 0.16 mm	3514068	
	◆ ●		* Filter sieve, 50 mesh per inch (rough)	3514069	
	◆ ●		* Filter sieve, 20 mesh per inch (rough)	291564	
12	◆	1	Cone spring	3514058	
13		1	Outlet pipe	2324552	
21		1	Pressure ring d45	2325562	
23		1	Hexagon plug	2323718	
34		1	Loctite® 542 50 ml; 50 cc	9992831	
35		1	Mobilux® EP2 grease	9998808	
36		1	Anti-seize paste tube	9992609	
37		1	Molykote® DX grease	9992616	

◆ = Wearing parts

● = Not part of the standard equipment but available as a special accessory.

**DANGER****Incorrect maintenance/repair!**

Danger to life and equipment damage.

- Only a WAGNER service center or a suitably trained person may carry out repairs and replace parts.
- Only repair and replace parts that are listed in the "Spare parts" chapter and that are assigned to the unit.
- Before all work on the device and in the event of work interruptions:
 - Relieve pressure from spray guns and devices.
 - Secure spray guns against actuation.
 - Switch off the energy/compressed air supply.
 - Disconnect the control unit from the mains.
- Observe the operating and service manual for all work.

13.7 HIGH-PRESSURE FILTER (UP TO 530 BAR; 7687 PSI)

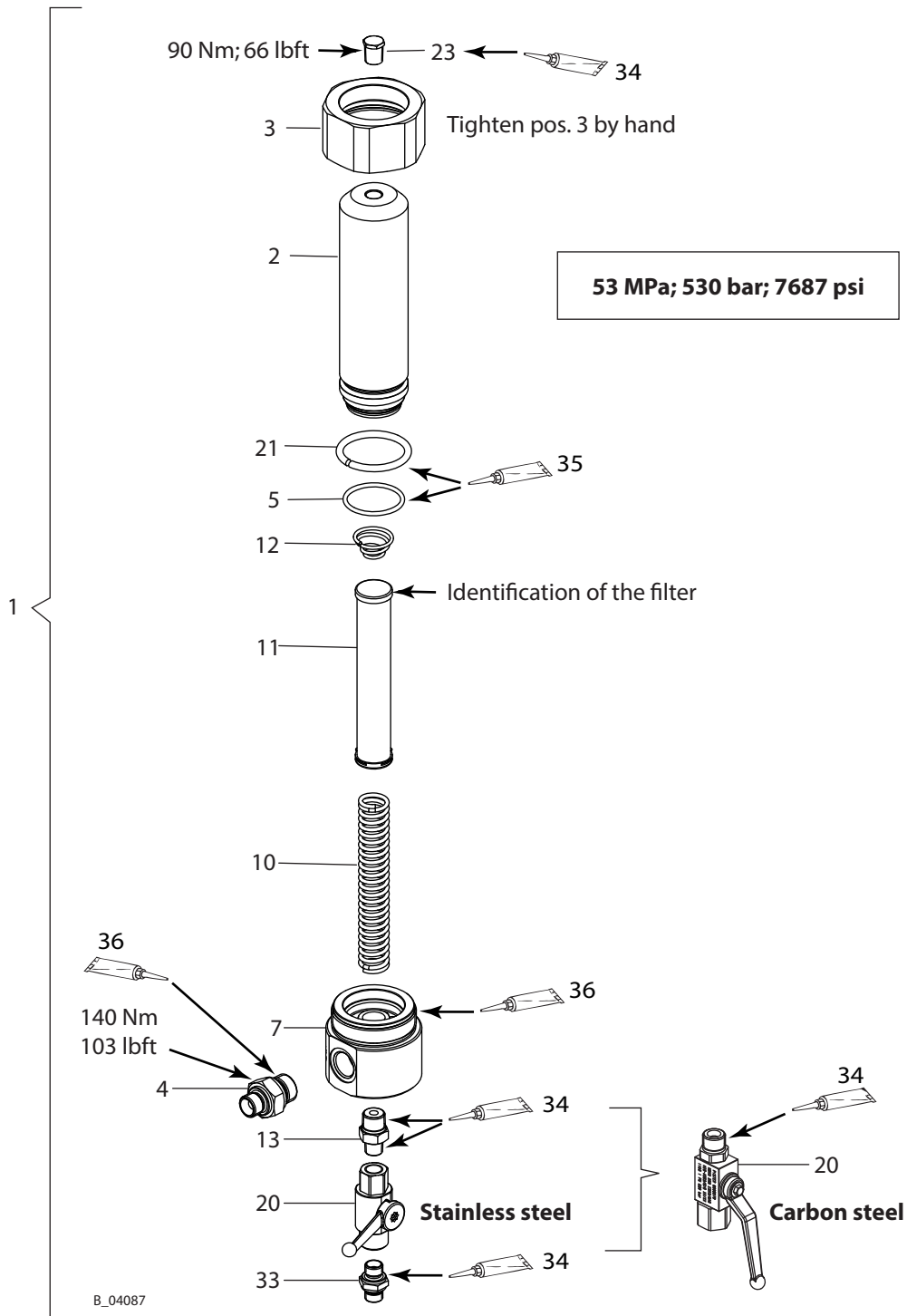

Spare parts list for high-pressure filter 530

			Ball valve version in:	Stainless steel	Carbon steel
Pos	K	Stk	Designation	Order No.	Order No.
1		1	HP filter DN12-PN530, complete	2329025	2335334
2		1	Filter housing	2324542	
3		1	Union nut	2324543	
4		1	Fitting-DF-MM-G1/2-G3/8-PN530-SSt	2330780	
5	◆	1	O-ring	9955863	
7		1	Distribution housing for ball valve	2324670	
10		1	Filter support	9894245	
11		1	Filter cartridge *		
	◆ ●		* Filter sieve, 200 mesh per inch (fine)	295721	
	◆		* Filter sieve, 100 meshes per inch (medium), mesh width 0.16 mm	3514068	
	◆ ●		* Filter sieve, 50 mesh per inch (rough)	3514069	
	◆ ●		* Filter sieve, 20 mesh per inch (rough)	291564	
12	◆	1	Cone spring	3514058	
13		1	Fitting-DF-MM-R3/8-R1/4-PN530-SSt	2328291	
20	◆	1	Ball valve	2330156	9998679
21		1	Pressure ring d45	2325562	
23		1	Hexagon plug	2323718	
33		1	Double connector	3204611	2325826
34		1	Loctite® 542 50 ml; 50 cc	9992831	
35		1	Mobilux® EP2 grease	9998808	
36		1	Anti-seize paste tube	9992609	

◆ = Wearing parts

● = Not part of the standard equipment but available as a special accessory.



DANGER

Incorrect maintenance/repair!

Danger to life and equipment damage.

- Only a WAGNER service center or a suitably trained person may carry out repairs and replace parts.
- Only repair and replace parts that are listed in the "Spare parts" chapter and that are assigned to the unit.
- Before all work on the device and in the event of work interruptions:
 - Relieve pressure from spray guns and devices.
 - Secure spray guns against actuation.
 - Switch off the energy/compressed air supply.
 - Disconnect the control unit from the mains.
- Observe the operating and service manual for all work.

13.8 TROLLEY

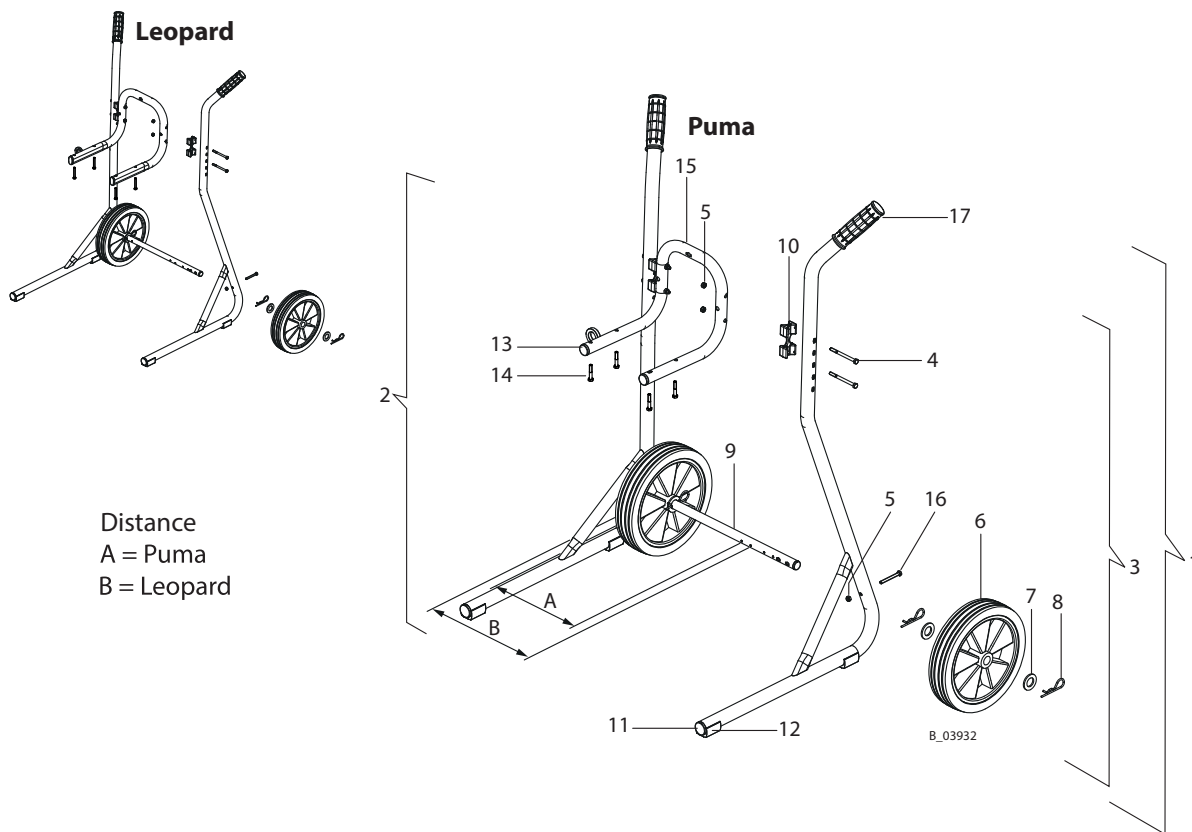

Pos	K	Stk	Designation	Order No. for Puma	Order No. for Leopard
1		1	Trolley, complete	2325901	2325916
2		1	Frame, left, 4"-6" (welded)	--	--
3		1	Frame, right, 4"-6" (welded)	--	--
4		4	Hexagon screw DIN931 M6x75	9907140	
5		6	Self-locking hexagon nut, M6	9910204	
6	◆	2	Wheel, D250	2304440	
7		4	Washer	340372	
8		4	Cotter pin	9995302	
9		1	Wheel axle 4"-6"	--	--
10	◆	2	Connecting part 4"-6"	367943	
11		2	Tube plug, ribbed	--	--
12		2	Saddle feet for round tubes	--	--
13		2	Plug	--	--
14		4	Hexagon screw	9900218	9900126
15		1	Wall mount	2332143	2332145
16		2	Hexagon screw without shaft M6x55	3061695	
17	◆	2	Handle	9998747	

◆ = Wearing parts

13.9 „HEAVY DUTY“ TROLLEY

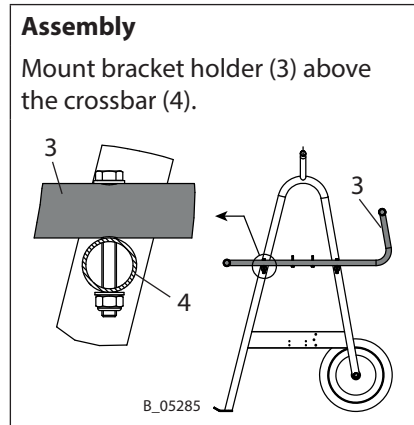
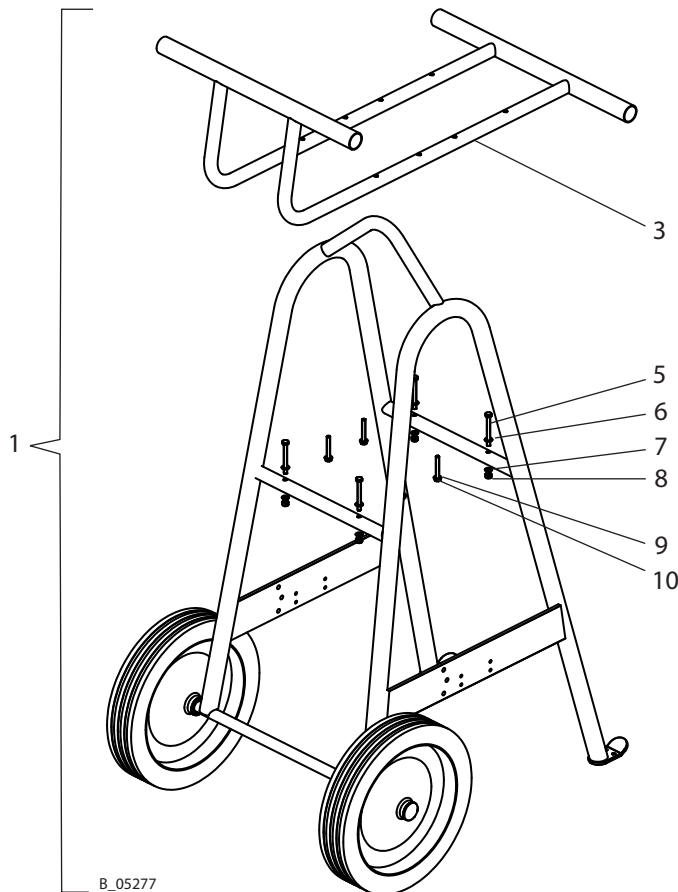

Spare parts list for PC heavy duty trolley

Pos	K	Stk	Designation	6"		9"	
				Order No. for Leopard 48-110		Order No. for Jaguar 75-150	
1		1	PC heavy duty trolley	2339705			
3		1	Bracket holder	--			
5		4	Hexagon screw	9900246			
6		4	Washer, A8.4	9920102			
7		4	Contact washer, M8	3155404			
8		4	Self-locking hexagon nut, M8	9910208			
9		4	Washer, A6.4 or A8.4	9925031	9920102		
10		4	Hexagon screw	9900126	9900130		

◆ = Wearing parts

14 WARRANTY AND CONFORMITY DECLARATIONS

14.1 IMPORTANT NOTES REGARDING PRODUCT LIABILITY

As a result of an EC regulation effective from January 1, 1990, the manufacturer shall only be liable for his product if all parts originate from him or are approved by him, and if the devices are properly mounted, operated and maintained.

The manufacturer will not be held liable or will only be held partially liable if third-party accessories or spare parts have been used.

With genuine WAGNER accessories and spare parts, you have the guarantee that all safety regulations are complied with.

14.2 WARRANTY CLAIM

Full warranty is provided for this device:

We will at our discretion repair or replace free of charge all parts which within 36 months in single-shift, 18 months in double-shift or 9 months in triple-shift operation from date of receipt by the purchaser are found to be wholly or substantially unusable due to causes prior to the sale, in particular faulty design, defective materials or poor workmanship.

The type of warranty provided is such that the device or individual components of the device are either replaced or repaired as we see fit. The resulting costs, in particular shipping charges, road tolls, labour and material costs will be borne by us except where these costs are increased due to the subsequent shipment of the device to a location other than the address of the purchaser.

We do not provide warranty for damage that has been caused or contributed to for the following reasons:

Unsuitable or improper use, faulty assembly or commissioning by the purchaser or a third party, normal wear, negligent handling, defective maintenance, unsuitable coating products, substitute products and the influence of chemical, electrochemical or electrical agents, except when the damage is attributable to us.

Abrasive coating products such as red lead, emulsions, glazes, liquid abrasives, zinc dust paints and so forth reduce the service life of valves, packings, spray guns, nozzles, cylinders, pistons etc. Wear and tear due to such causes are not covered by this warranty.

Components that have not been manufactured by WAGNER are subject to the original warranty of the manufacturer.

Replacement of a component does not extend the period of warranty of the device.

The device should be inspected immediately upon receipt. To avoid losing the warranty, we or the supplier company are to be informed in writing about obvious faults within 14 days upon receipt of the device.

We reserve the right to have the warranty compliance met by a contracting company.

The services provided by this warranty are dependent on evidence being provided in the form of an invoice or delivery note. If the examination discovers that no warranty claim exists, the costs of repairs are charged to the purchaser.

It is clearly stipulated that this warranty claim does not represent any constraint on statutory regulations or regulations agreed to contractually in our general terms and conditions.

14.3 CE DECLARATION OF CONFORMITY

Herewith we declare that the supplied version of pneumatic pumps and their spraypacks:

Puma	Leopard	Jaguar
8-300	18-300	38-300
3-600	8-600	

complies with the following guidelines:

2006/42/EC	94/9/EC
------------	---------

Applied standards, in particular:

DIN EN ISO 12100: 2010	DIN EN ISO 13732-1: 2008	DIN EN 13463-1: 2009
DIN EN 809: 1998+A1: 2009+AC: 2010	DIN EN 14462: 2005+A1: 2009	DIN EN 13463-5: 2011
DIN EN ISO 4413: 2010	DIN EN 12621: 2006+A1: 2010	DIN EN ISO/IEC 80079-34: 2011
DIN EN ISO 4414: 2010	DIN EN 1127-1: 2011	

Applied national technical standards and specifications, in particular:

DGUV regulation 100-500	TRBS 2153
-------------------------	-----------

Identification:

CE **Ex** II 2 G c IIB T3/T4 X

T3: Without dry running protection.

T4: With dry running protection.

EC Certificate of Conformity

The CE certificate of conformity is enclosed with this product. If needed, further copies can be ordered through your WAGNER dealer by specifying the product name and serial number.

Order number: 2302304

14.4 NOTES ON NATIONAL REGULATIONS AND GUIDELINES

- a) Betr.Sich.V. Plant Safety Ordinance
- b) BGI 740 Painting rooms and equipment
- c) BGR 180 Equipment for cleaning work pieces with solvents
- d) DGUV regulation 100-500 Operating working materials
- e) TRBS 2153 Avoidance of ignition dangers due to electrostatic charges
- f) TRBS 1201 Checking working materials and systems which require monitoring
 - Part 1: Checking systems in areas subject to explosion hazards and checking of work stations in areas subject to explosion hazards
 - Part 3: Repairs to devices, protective systems, safety, control and regulation fixtures, in the sense of the 94/9/EC Directive - Determination of checking necessity according to § 14 sec. 6 BetrSichV (Industrial Safety Regulations)

Note: All titles can be ordered from Heymanns Publishing House in Cologne, or they can be found on the Internet.

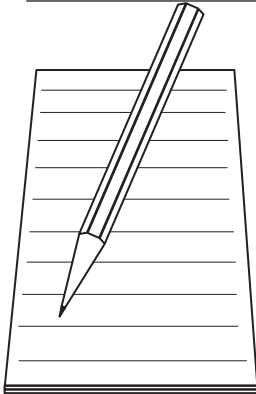

A large area containing multiple horizontal lines for writing, extending across the width of the page.

WAGNER



Order No. 2333548
Edition 07/2015

Germany

J. WAGNER GmbH
Otto-Lilienthal-Str. 18
Postfach 1120

D- 88677 Markdorf

Phone +49/ (0)7544 / 5050
Telefax +49/ (0)7544 / 505200
E-mail service.standard@wagner-group.com

Switzerland

J. WAGNER AG
Industriestrasse 22
Postfach 663

CH- 9450 Altstätten

Phone +41/ (0)71 / 757 2211
Telefax +41/ (0)71 / 757 2222

More contact addresses on the internet at:

www.wagner-group.com

Company/Locations/WAGNER worldwide

Subject to changes without notice