

**WAGNER**

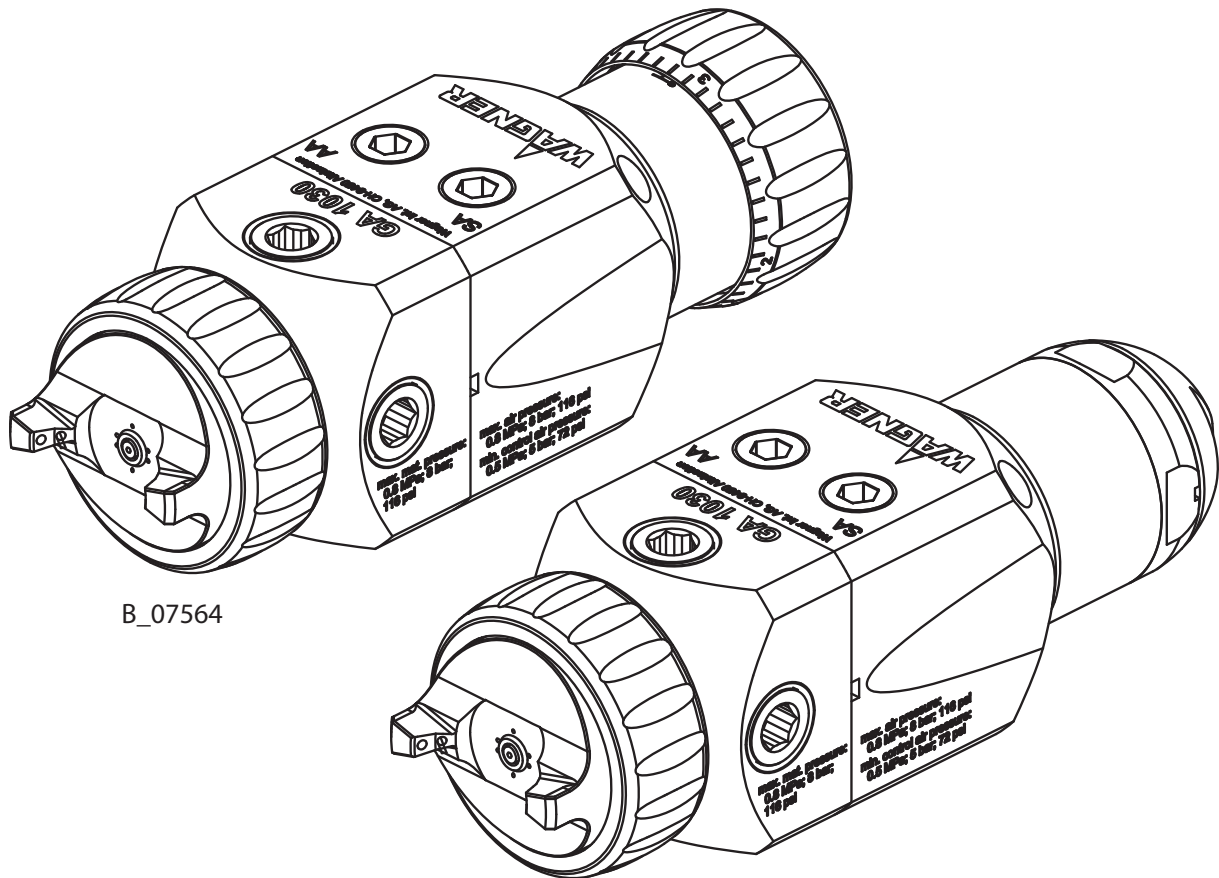

B\_07564

## AirSpray Automatic-Spray Gun

**GA 1020 / 1030**

Translation of the Original Operating Manual

CE  II 2G X

For professional use.

Always observe the information in this manual, particularly the safety instructions and the warning instructions. Store the manual in a safe place.

Edition: 07/2021



## TABLE OF CONTENTS

<b>1</b>	<b>About these instructions</b>	<b>6</b>
1.1	Preface	6
1.2	Warnings, Notices and Symbols in these Instructions	6
1.3	General Characters and Symbols	6
1.4	Languages	7
1.5	Abbreviations	7
1.6	Terminology for the Purpose of this Manual	7
<b>2</b>	<b>Using in accordance with the instructions</b>	<b>9</b>
2.1	Device Type	9
2.2	Type of Use	9
2.3	Field of application	9
2.4	Processible Working Materials	9
2.5	Misuse	9
<b>3</b>	<b>Identification</b>	<b>10</b>
3.1	Explosion Protection Identification	10
3.2	Identification "X"	10
3.3	Type Plate	11
<b>4</b>	<b>Basic Safety Instructions</b>	<b>12</b>
4.1	Safety Instructions for the Operator	12
4.1.1	A Safe Work Environment	12
4.1.2	Personnel Qualifications	12
4.2	Safety Instructions for the Personnel	13
4.2.1	Personal Safety Equipment	13
4.2.2	Safe Handling of WAGNER Spray Devices	13
4.2.3	Grounding the Device	14
4.2.4	Product Hoses	14
4.2.5	Cleaning and Flushing	15
4.2.6	Touching Hot Surfaces	15
4.2.7	Maintenance and Repair	16
4.2.8	Protective and Monitoring Equipment	16
<b>5</b>	<b>Description</b>	<b>17</b>
5.1	Components	17
5.2	Distinguishing Features	18
5.3	Configurations	19
5.4	Extent of Delivery	19
5.5	Technical data	19
5.5.1	Materials of the parts transporting paint	19
5.5.2	Technical Data	19
5.5.3	Air flow	20
5.5.4	Connections	22
5.5.5	Options for Product Supply	23
<b>6</b>	<b>Assembly and Commissioning</b>	<b>24</b>
6.1	Training of Assembly/Commissioning Personnel	24
6.2	Storage Conditions	24
6.3	Installation Conditions	24
6.4	Connecting Automatic Spray Gun	24
6.4.1	Typical Airspray Spraying System	24
6.4.2	Ventilation of the Spray Booth	25

6.4.3	Air Supply Lines	25
6.4.4	Product Supply Lines	26
6.5	Grounding	26
6.6	Safety Checks	26
6.7	Lacquer Preparations	26
6.7.1	Viscosity conversion table	26
6.8	Start up	27
6.8.1	Preparation Before Commissioning	27
6.8.2	Procedure	27
6.8.3	Verifying a Safe Operational Condition	28
<b>7</b>	<b>Operation</b>	<b>29</b>
7.1	Training the Operating Personnel	29
7.2	Tasks	29
7.3	Adjusting the Spray Pattern	29
7.3.1	Adjusting Spray Pattern	30
7.3.2	Setting the Product Flow Rate	30
7.4	Pressure Relief / Work Interruption	31
7.5	Basic Flushing	31
<b>8</b>	<b>Cleaning and Maintenance</b>	<b>32</b>
8.1	Cleaning	32
8.1.1	Cleaning Personnel	32
8.1.2	Flushing and Cleaning the Automatic Spray Gun	32
8.2	Maintenance	32
8.2.1	Maintenance Personnel	32
8.2.2	Safety instructions	33
8.2.3	Safety Checks and Maintenance Intervals	33
8.3	Changing the Nozzle	34
8.4	Changing the Piston	36
8.5	Replacing the Needle Packing (Only GA 1030)	38
8.6	Converting from EC to IC	41
8.7	Converting from a Distribution Line to a Circuit	42
<b>9</b>	<b>Trouble shooting and solution</b>	<b>44</b>
<b>10</b>	<b>Repairs</b>	<b>45</b>
10.1	Repair Personnel	45
10.2	Repair Notes	45
10.3	Tools	45
10.4	Disassembly	46
10.5	Assembly	48
10.6	Supporting Bar Assembly	50
10.6.1	On Spray Gun	50
10.6.2	On Adapter Plate	51
<b>11</b>	<b>Function Test after Repair Work</b>	<b>52</b>
<b>12</b>	<b>Disposal</b>	<b>53</b>
<b>13</b>	<b>Accessories</b>	<b>54</b>
13.1	Nozzles	54
13.2	Nozzle Needle Sets for GA 1020	54
13.3	Nozzle Needle Sets for GA 1030	54
13.4	Air caps	55
13.5	Connection Plate and Adapter	55

<b>14</b>	<b>Spare parts</b>	<b>57</b>
14.1	How to order spare parts	57
14.2	GA 1020 / 1030 automatic spray gun	58
14.2.1	Adapter plate "Product connections at side"	59
14.2.2	Adapter plate "Product connections at rear"	60
14.2.3	Adapter plate "Flushing valve"	60
<b>15</b>	<b>EU Declaration of Conformity</b>	<b>62</b>

# 1 ABOUT THESE INSTRUCTIONS

## 1.1 PREFACE

The operating manual contains information about safely operating, maintaining, cleaning and repairing the device. The operating manual is part of the device and must be available to the operating and service personnel.





The device may only be operated by trained personnel and in compliance with this operating manual. Operating and service personnel should be instructed according to the safety instructions.

This equipment can be dangerous if it is not operated according to the instructions in this operating manual.

## 1.2 WARNINGS, NOTICES AND SYMBOLS IN THESE INSTRUCTIONS

Warning instructions in this manual highlight particular dangers to users and to the device and state measures for avoiding the hazard.

These warning instructions fall into the following categories:

	<b>DANGER</b>	Immediate risk of danger. Non-observance will result in death or serious injury.
	<b>WARNING</b>	Potential danger. Non-observance may result in death or serious injury.
	<b>CAUTION</b>	Potentially dangerous situation. Non-observance may result in minor injury.
	<b>NOTICE</b>	Potentially dangerous situation. Non-observance may result in damage to property.
	<b>Info</b>	Provides information about particular characteristics and how to proceed.

### Explanation of warning notice:

#### **WARNING**

**This notice warns you of a danger!**

Possible consequences of not observing the warning notice.

- ▶ The measures for preventing the hazard and its consequences.



## 1.3 GENERAL CHARACTERS AND SYMBOLS

The characters and symbols in this operating manual indicate the following:

✓ Requirement that must be fulfilled before an action can be performed.

1. Step 1 of an action to be performed with several action steps.

- ▶ Second level action step

2. Step 2

⇒ Intermediate result of an action

⇒ Result of a complete action

- ▶ Action to be performed with an action step

1. Numbered list, first level

- Numbered list, second level

- Non-numbered list, first level
  - Non-numbered list, second level

[▶▶ 8] = cross-reference on page

◆ = wearing parts

\* = included in service set

● = not part of the standard equipment but available as a special accessory

## 1.4 LANGUAGES

The operating manual is available in the following languages:

### Original operating manual

Language	Order no.
German	2407547

### Translation of the original operating manual

Language	Order no.	Language	Order no.
English	2407555	Russian	2407559
French	2407556	Chinese	2407560
Italian	2407557	Japanese	2430244
Spanish	2407558		

Additional languages upon request or at: [www.wagner-group.com](http://www.wagner-group.com)

## 1.5 ABBREVIATIONS

Order no.	Order number
ET	Spare part
K	Marking in the spare parts lists
Pos	Position
Stk	Number of pieces
SW	Wrench size

## 1.6 TERMINOLOGY FOR THE PURPOSE OF THIS MANUAL

### Cleaning

Cleaning	Manual cleaning of devices and device parts with cleaning agent.
Flushing	Internal flushing of paint-wetted parts with flushing agent.
Product pressure generator	Pump or pressure tank.

### Personnel qualifications

Trained person	Is instructed in the tasks assigned to him/her, the potential risks associated with improper behavior as well as the necessary protective devices and measures.
Electrically trained person	Is instructed by an electrician about the tasks assigned to him/her, the potential risks associated with improper behavior as well as the necessary protective devices and measures.
Electrician	Can assess the work assigned to him/her and detect possible hazards based on his/her technical training, knowledge and experience in relevant provisions.
Skilled person in accordance with TRBS 1203 (2010/Revision 2012)	A person, who, based on his/her technical training, experience and recent vocational experience, has sufficient technical knowledge in the areas of explosion protection, protection from pressure hazards and electric hazards (if applicable) and is familiar with the relevant and generally accepted rules of technology so that he/she can inspect and assess the status of devices and coating systems based on workplace safety.



## 2 USING IN ACCORDANCE WITH THE INSTRUCTIONS

### 2.1 DEVICE TYPE

Automatic spray gun for automatic coating of work pieces:

### 2.2 TYPE OF USE

The automatic spray gun is suitable for atomizing liquid products, particularly coating products, using the AirSpray process.

WAGNER explicitly prohibits any other use!

Thanks to its compact construction and its low weight, the automatic spray gun is especially suitable for use on automatic coating machines and robots.

The device may only be operated under the following conditions:

- ▶ Use the device only to work with the materials recommended by WAGNER.
- ▶ Do not deactivate safety fixtures.
- ▶ Use only WAGNER original spare parts and accessories.
- ▶ The operating personnel must be trained on the basis of this operating manual.
- ▶ Follow the instructions in the operating manual.

### 2.3 FIELD OF APPLICATION

As defined in Directive 2014/34/EU (ATEX), the device is suitable for use in potentially explosive areas (see Explosion Protection Identification [▶▶ 10]).



### 2.4 PROCESSIBLE WORKING MATERIALS

Top-coat lacquers, primer paints, corrosion protection, textured lacquers, lyes, staining solvents, clear lacquers, separating agents, etc. with a solvent or water base. If you want to process working materials other than the aforementioned, please contact a WAGNER representative.

When operating the device with a coating product with a temperature greater than 43 °C; 109.4 °F, identify the device with a warning label that says "Warning - hot surface" according to Touching Hot Surfaces [▶▶ 15].

#### Info

Contact your local WAGNER dealer and the lacquer manufacturer if you encounter application problems.



### 2.5 MISUSE

Misuse can lead to physical injury and/or property damage! Special attention must be paid that:

- ▶ No dry coating products, e.g., powder are processed.
- ▶ No food, medicine or cosmetics are processed. It is important to note that the device's materials are not food-safe.

## 3 IDENTIFICATION

### 3.1 EXPLOSION PROTECTION IDENTIFICATION

As defined in Directive 2014/34/EU (ATEX), the device is suitable for use in potentially explosive areas.

Device Type	GA 1020 / 1030 automatic spray gun
Manufacturer	Wagner International AG 9450 Altstätten Switzerland

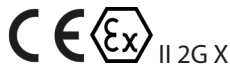

CE	European Communities
Ex	Symbol for explosion protection
II	Device class II
2	Category 2 (zone 1)
G	Ex-atmosphere gas
X	Special notice



### 3.2 IDENTIFICATION "X"

The maximum surface temperature corresponds to the permissible product temperature. This and the permissible ambient temperature can be found in Chapter Technical Data [▶▶ 19].

#### Safe Handling of WAGNER Spray Devices

Mechanical sparks can form if the device comes into contact with metal. In an explosive atmosphere:

- ▶ knocking or pushing metal against metal is to be avoided;
- ▶ Do not drop the device.

#### Ignition temperature of the coating product

- ▶ Ensure that the ignition temperature of the coating product is above the maximum surface temperature.

#### Medium supporting atomizing

- ▶ To atomize the product, use only weakly oxidizing gases, e.g., air.

#### Cleaning

If there are deposits on the surfaces, the device may form electrostatic charges. Flames or sparks can form during discharge.

1. Remove deposits from the surfaces to maintain conductivity.
2. Use only a damp cloth to clean the device.



### 3.3 TYPE PLATE

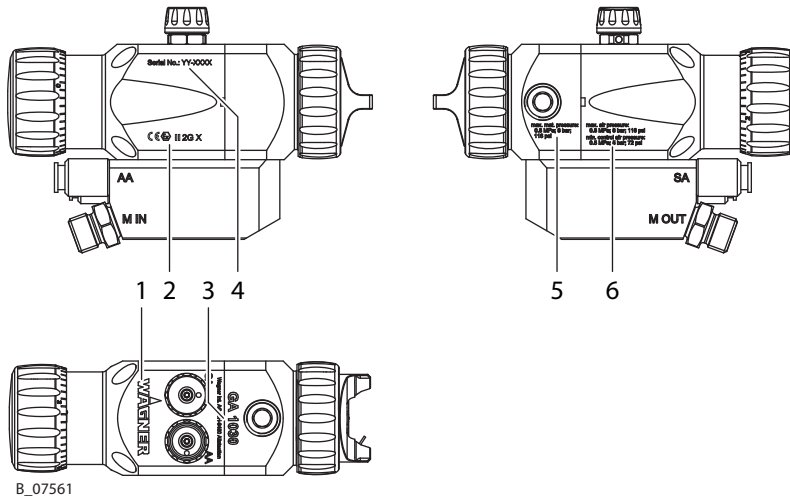

1	Wagner logo	4	Serial number, year
2	CE and explosion protection identification	5	Maximum product pressure
3	Type designation, GA 1020 or GA 1030	6	Maximum air inlet pressure / minimum control air pressure

## 4 BASIC SAFETY INSTRUCTIONS

### 4.1 SAFETY INSTRUCTIONS FOR THE OPERATOR

- ▶ Keep this operating manual at hand near the device at all times.
- ▶ Always follow existing regulations concerning occupational safety and accident prevention regulations.



#### 4.1.1 A Safe Work Environment

##### **Danger due to dangerous fluids or vapors!**

Severe or fatal injuries due to explosion danger or inhalation, swallowing or contact with the skin or eyes.

- ▶ Ensure that the floor in the working area is static dissipative in accordance with EN 61340-4-1 (resistance must not exceed 100 MΩ).
- ▶ Paint mist extraction systems/ventilation systems must be fitted on site according to local regulations.
- ▶ Make sure that the ground connection and potential equalization of all system parts are reliable and continuous and can withstand the expected stress (e.g., mechanical stress, corrosion).
- ▶ Ensure that product hoses/air hoses adapted to the working pressure are used.
- ▶ Ensure that personal protective equipment is available and is used.
- ▶ Make sure that all people within the work area wear static dissipative shoes. Footwear must comply with EN 20344. The measured insulation resistance must not exceed 100 MΩ.
- ▶ Ensure that during spraying, persons wear static dissipative gloves. The grounding takes place via the spray gun's handle or its trigger.
- ▶ Protective clothing, including gloves, must comply with EN 1149-5. The measured insulation resistance must not exceed 100 MΩ.
- ▶ Ensure that there are no ignition sources such as naked flames, sparks, glowing wires, or hot surfaces in the vicinity. Do not smoke.
- ▶ Ensure that the pipe joints, hoses, equipment parts and connections are permanently, technically leak-proof:
  - ▶ Periodic preventative maintenance and service (replacing hoses, checking tightness strength of connections, etc.)
  - ▶ Regular monitoring of leaks and defects via visual inspection and odor testing, e.g., daily before commissioning, at the end of work or weekly.
- ▶ Ensure that maintenance and safety checks are performed regularly.
- ▶ In the event of defects, immediately bring the device or system to a stop and arrange to have repairs carried out immediately.



#### 4.1.2 Personnel Qualifications

##### **Danger due to incorrect use of device!**

Risk of death due to untrained personnel.

- ▶ Ensure that the operating personnel has been instructed by the operator in accordance with the operating manual and the operating instructions. The device must only be operated, maintained and repaired by trained personnel. Refer to the operating instructions for information about the required personnel qualifications.

## 4.2 SAFETY INSTRUCTIONS FOR THE PERSONNEL

- ▶ Always observe the information in this manual, particularly the safety instructions and the warning instructions.
- ▶ Always follow existing regulations concerning occupational safety and accident prevention regulations.



### **Danger due to high-voltage field!**

Danger to life from malfunction of active implants.

- ▶ Persons belonging to a risk group according to EMF guideline 2013/35/EU (e.g., carriers of active implants), must not enter the high-voltage area.



### 4.2.1 Personal Safety Equipment

#### **Danger due to dangerous fluids or vapors!**

Serious or fatal injuries due to inhalation, swallowing or contact with the skin or eyes.

- ▶ When preparing or working with lacquer and when cleaning the device, follow the working instructions of the manufacturer of the lacquers, solvents and cleaning agents being used.
- ▶ Implement the prescribed safety measures, in particular the wearing of safety glasses, safety clothing and protective gloves as well as the use of protective hand cream.
- ▶ Use a mask or breathing apparatus if necessary.
- ▶ For sufficient health and environmental safety: Operate the device in a spray booth or on a spraying wall with the ventilation (extraction) switched on.
- ▶ Wear suitable protective clothing when working with hot products.



### 4.2.2 Safe Handling of WAGNER Spray Devices

#### **Danger due to injection of lacquer or flushing agent into the skin!**

The spray jet is under pressure and can cause dangerous injuries.

Avoid injection of lacquer or flushing agents:

- ▶ Never point the spray gun at people.
- ▶ Never reach into the spray jet.
- ▶ Perform the following measures before any work on the device, in the event of work interruptions and malfunctions:
  - ▶ Switch off the energy/compressed air supply
  - ▶ Relieve the pressure from the spray gun and device
  - ▶ Securing the Spray Gun Against Actuation
  - ▶ Disconnect the control unit from the mains
  - ▶ In the event of functional faults, remedy the fault as described in the Troubleshooting chapter
- ▶ If needed, the liquid ejection devices must be checked by experts (e.g., WAGNER service technician) at least every 12 months for their work-safe condition in accordance with DGUV regulation 100-500 Chapter 2.29 and Chapter 2.36.
  - ▶ For shut down devices, the examination can be suspended until the next start-up.



#### **In the event of skin injuries caused by lacquer or flushing agents:**

- ▶ Note the lacquer or flushing agent that you have been using.
- ▶ Consult a doctor immediately.

### 4.2.3 Grounding the Device

#### Danger due to electrostatic charge!

Risk of injury, explosion hazard and damage to the device.

Friction, flowing liquids and air or electrostatic coating processes create charges. Flames or sparks can form during discharge. Correct grounding of the entire spraying system prevents electrostatic charges.

- ▶ Ensure that all devices and tanks are grounded before each spraying process.
- ▶ Make sure that the ground and potential equalization of all system parts are performed reliably and continuously and can withstand the expected stress (e.g., mechanical stress, corrosion).
- ▶ Earth the workpieces being painted.
- ▶ Ensure that all persons inside the working area are grounded, e.g., that they are wearing static dissipative shoes.
- ▶ Wear static dissipative gloves when spraying. The grounding takes place via the spray gun's handle or its trigger.



### 4.2.4 Product Hoses

#### Danger due to bursting of product hose!

The product hose is under pressure and may cause dangerous injuries.

- ▶ Ensure that the hose material is chemically resistant to the sprayed products and the flushing agents used.
- ▶ Ensure that the product hoses and the fittings are suitable for the pressure generated.
- ▶ Ensure that the following information can be seen on the high-pressure hose:
  - ▶ Manufacturer
  - ▶ permissible operating pressure
  - ▶ Date of manufacture
- ▶ Make sure that the hoses are laid only in suitable places. Hoses should not be laid in the following places under any circumstances:
  - ▶ in high traffic areas
  - ▶ on sharp edges
  - ▶ on moving parts
  - ▶ on hot surfaces
- ▶ Ensure that the hoses are never run over by vehicles (e.g., fork lifts), or that the hoses are never put under pressure from the outside in any other way.
- ▶ Ensure that the hoses are never kinked. Observe maximum bending radii.
- ▶ Ensure that no work is ever performed with a damaged hose.
- ▶ Make sure that the hoses are never used to pull or move the device.
- ▶ The electrical resistance of the product hose, measured at both valves, must be less than 1 MΩ.
- ▶ Suction hoses may not be subjected to pressure.



#### 4.2.5 Cleaning and Flushing

##### **Danger due to cleaning and flushing!**

Explosion hazard and damage to the device.

- ▶ Non-ignitable cleaning agents and flushing agents should preferably be used.
- ▶ When carrying out cleaning work with flammable cleaning agents, make sure that all equipment and resources (e.g., collection tank, funnel, transport cart) are conductive or static dissipative and grounded.
- ▶ Observe the specifications of the lacquer manufacturer.
- ▶ Ensure that the flash point of the cleaning agent is at least 15 K above the ambient temperature or that cleaning is undertaken at a cleaning station with technical ventilation.
- ▶ Never use chloride or halogenated solvents (such as trichloroethane and methylene chloride) with devices containing aluminium or galvanized/zinc-plated parts. They may react chemically thus producing an explosion danger.
- ▶ Take measures for workplace safety.
- ▶ It should be noted that when the device is put into operation or emptied: depending on the coating product used, depending on the rinsing agent (solvent) used, there may briefly be a mixture inside the pipes and equipment which can ignite.
- ▶ Only use electrically conductive tanks for cleaning and flushing agents.
- ▶ The tanks must be grounded.

An explosive gas/air mixture forms in closed tanks.

- ▶ Never spray into a closed tank when using solvents for flushing.

##### **External Cleaning**

When cleaning the exterior of the device or its parts, also observe the following:

- ▶ Relieve the pressure from the device.
- ▶ De-energize the device electrically.
- ▶ Disconnect the pneumatic supply line.
- ▶ Use only moistened cloths and brushes. Never use abrasive agents or hard objects and never spray cleaning agents with a gun. Cleaning the device must not damage it in any way.
- ▶ Ensure that no electric component is cleaned with or immersed into solvent.

#### 4.2.6 Touching Hot Surfaces

##### **Danger due to hot surfaces because of hot coating products!**

Risk of burn injuries

- ▶ Only touch hot surfaces if you are wearing protective gloves.
- ▶ When operating the device with a coating product with a temperature of > 43 °C; 109 °F, apply a warning label to the device that says "Warning - Hot Surface."

Instruction label: Order no. 9998910

Protection label: Order no. 9998911

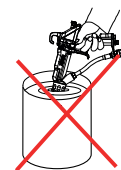

## Info

Order the two labels together.



### 4.2.7 Maintenance and Repair

#### **Danger due to improper maintenance and repair!**

Danger to life and equipment damage.

- ▶ Only a WAGNER service center or a suitably trained person may carry out repairs and replace parts.
- ▶ Repair or replacement of devices or parts of devices are only allowed to be performed outside the hazard area by qualified personnel.
- ▶ Use only WAGNER original spare parts and accessories.
- ▶ Do not change or modify the device; if change is necessary, contact WAGNER.
- ▶ Only repair and replace parts that are listed in Chapters Accessories [▶ 54] and Spare Parts and that are assigned to the device.
- ▶ Do not use any defective components.
- ▶ Before all work on the device and in the event of work interruptions:
  - ▶ Relieve the pressure from the spray gun, product hoses and all devices.
  - ▶ Secure the spray gun against actuation.
  - ▶ Switch off the energy and compressed air supply.
  - ▶ Disconnect the control unit from the mains.
- ▶ Observe the operating and service manual for all work.

### 4.2.8 Protective and Monitoring Equipment

#### **Danger due to removal of protective and monitoring equipment!**

Danger to life and equipment damage.

- ▶ Protective and monitoring equipment must not be removed, modified or rendered unusable.
- ▶ Regularly check for perfect functioning.
- ▶ If defects are detected on protective and monitoring equipment, the system must not be operated until these defects are remedied.



## 5 DESCRIPTION

### 5.1 COMPONENTS

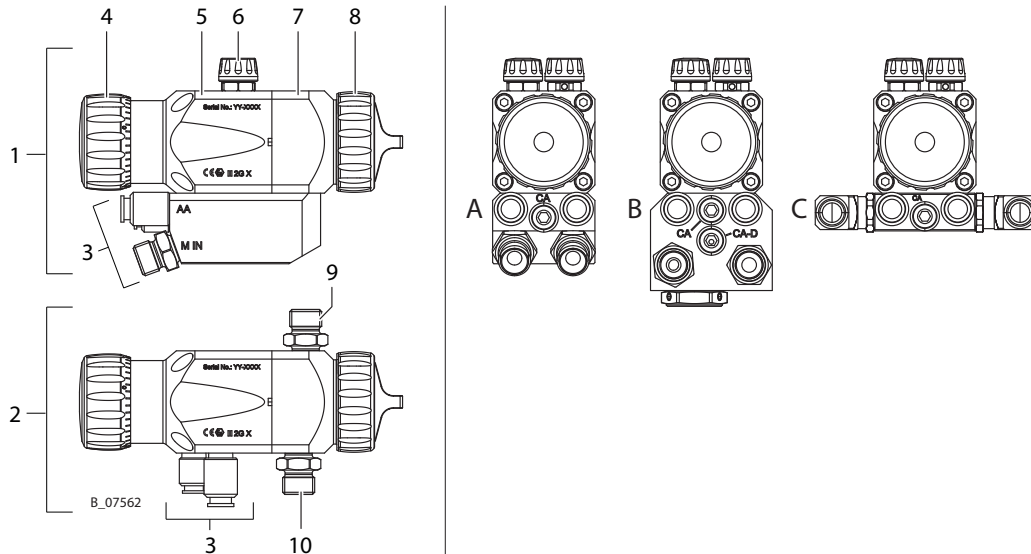

Pos	Designation	Internal control	
		With	Without
A	Spray gun with adapter plate "Product connections at rear"	-	-
B	Spray gun with adapter plate "Flushing valve"	-	-
C	Spray gun with adapter plate "Product connections at side"	-	-
1	Spray gun, version with adapter plate (see Chapter Options for Product Supply [ >> 23])	x	x
2	Spray gun, version without adapter plate (see Chapter Options for Product Supply [ >> 23])	x	x
3	Control air, atomizing air and product connections (see Chapter Connections [ >> 22])	-	-
4	Control dial to regulate product flow rate	-	-
5	Rear side of spray gun body (fixed or adjustable needle stroke)	-	-
6	Regulating screws for adjusting the spray pattern	x	-
7	Front side of spray gun body (GA 1020 or GA 1030)	-	-
8	Air cap / nozzle	-	-
9	Product connection (without adapter plate, see Chapter Options for Product Supply [ >> 23])	x	-
10	Product connection (without adapter plate, see Chapter Options for Product Supply [ >> 23])	x	x

### MODE OF OPERATION

The automatic spray guns **GA 1020** and **GA 1030** operate fully automatically via a compressed air controller.

**GA 1020:** Version with diaphragm seal for abrasive products such as UV lacquers and max. of 2.5 bar.

**GA 1030:** Version with needle packing up to 8 bar.

As soon as the required compressed air for the controller is available, the atomizing air and shaping air channels are opened. Then the product feed is opened.

If the control air is interrupted, the product needle is pressed back into the initial position and closes the product and atomizing air supply.

## 5.2 DISTINGUISHING FEATURES

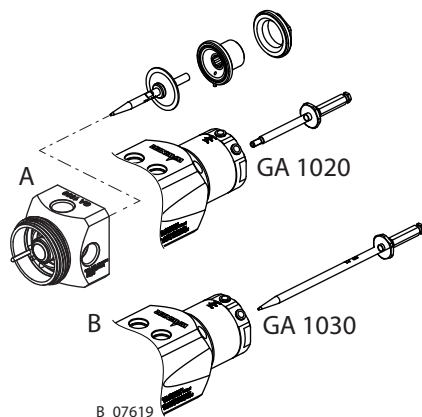

### GA 1020 spray gun (A):

The GA 1020 version has a 2-part needle with diaphragm in the front gun area. The rear part of the needle is screwed in and cannot be easily pulled out, as with the GA 1030. This version is especially suitable for abrasive products such as UV lacquers. Here, the top of the pressure range is 2.5 bar

### GA 1030 spray gun (B):

The GA 1030 version has a continuous needle with needle packing and is permissible up to 8 bar.

**Note:** The spray gun version (GA 1020 or GA 1030) is printed, respectively, on the gun body.

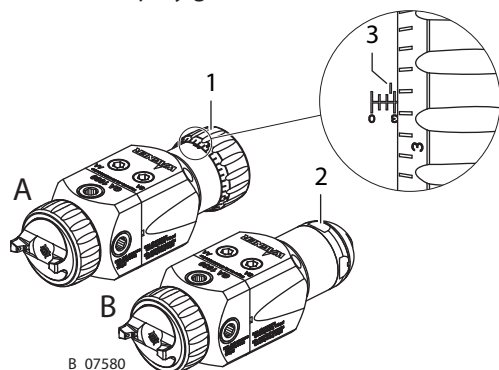

### Adjustable needle stroke (A):

The version with adjustable needle stroke has an adjusting cap (1) with grid and scale, in order to adjust the needle stroke.

The markings on the scale (3) show the maximum needle stroke that can be set with the GA 1020 spray gun (version with diaphragm). The adjusting screw can be turned back further, but this has no further effect on the needle stroke.

### Fixed needle stroke (B):

The version with fixed needle stroke has an end cap (2) and cannot be adjusted.

**Note:** Both versions are available for the GA 1020 and the GA 1030.

### 5.3 CONFIGURATIONS

The following configurations are possible:

GA 1020 or GA 1030 spray gun variants (see chapter Distinguishing Features [ >> 18])

Adjustable or fixed needle stroke (see Chapter Distinguishing Features [ >> 18])

Combination with supporting bar (see Chapter Supporting Bar Assembly [ >> 50])

Combination with diverse adapter plates (see Chapter Connection Plate and Adapter [ >> 55])

Combination of diverse needles and nozzles (see Chapter Nozzle Needle Sets for GA 1020 [ >> 54] and ), as well as different air caps depending on the area of application (see Chapter Air caps [ >> 55])

### 5.4 EXTENT OF DELIVERY

Stk	Order no.	Designation
1	2406824	GA 1020/1030 VC automatic spray gun (configurator)
1	2407800	CE Declaration of Conformity
1	2407547	Operating manual, in German
1	see Chapter Languages [ >> 7]	Operating manual in local language
--	see Chapter Accessories [ >> 54]	Accessories

The exact scope of delivery corresponds to the configured spray gun and is shown in the delivery note.

### 5.5 TECHNICAL DATA

#### 5.5.1 Materials of the parts transporting paint

Paint-wetted parts	Product
Nozzle	Stainless steel
Valve needle	Stainless steel, hardened

#### 5.5.2 Technical Data

Description	Units	Value
Maximum pressure for atomizing air	MPa; psi; bar	0.8; 116; 8
Maximum pressure for horn air / shaping air	MPa; psi; bar	0.8; 116; 8
Maximum pressure for control air	MPa; psi; bar	0.8; 116; 8
Minimum pressure for control air	MPa; psi; bar	0.5; 72.5; 5
Maximum product pressure - GA 1020	MPa; psi; bar	0.25; 36; 2.5
Maximum product pressure - GA 1030	MPa; psi; bar	0.8; 116; 8
Compressed air quality: free from oil and water	Quality standard 7.5.4 in accordance with ISO 8573.1, 2010 7: Particle concentration 5–10 mg/m <sup>3</sup> 5: Humidity: Pressure condensation point ≤ +7 °C 4: Oil content ≤ 5 mg/m <sup>3</sup>	
Maximum product temperature	°C; °F	80; 176

Description	Units	Value
Maximum air temperature	°C; °F	50; 122
Weight	g; oz	approx. 650; 22.9
Maximum ambient temperature	°C; °F	5–40; 41–104

**⚠ WARNING**

**Exhaust air containing oil!**

Risk of poisoning if inhaled.

- ▶ Provide compressed air free from oil and water.



### 5.5.3 Air flow

Explanation of the abbreviations used in the table:

AA = atomizing air

SA = shaping air

Air cap	Character-istic	Inlet pressure (MPa; bar; psi)					
		0.1; 1; 14.5	0.2; 2; 29.0	0.3; 3; 43.5	0.4; 4; 58.0	0.5; 5; 72.5	0.6; 6; 87.0
HVLP AAH	1	133	207	279	354	431	503
HVLP SA	1	127	193	255	323	391	460
HVLP+ AA	2	85	134	175	219	269	325
HVLP+ SA	2	94	144	190	234	282	330
CONV8 AA	3	73	115	155	193	236	290
CONV8 SA	3	113	171	226	285	343	404
CONV10 AA	4	74	117	155	195	241	296
CONV10 SA	4	111	170	223	281	340	398
CONV12 AA	5	89	139	183	228	282	347
CONV12 SA	5	111	168	222	279	338	398
CONV14 AA	6	82	130	170	213	262	320
CONV14 SA	6	111	170	225	283	342	401

Information on air flow in nl/min with an inlet pressure between 0.1; 1; 14.5 and 0.6; 6; 87.0 (MPa; bar; psi).

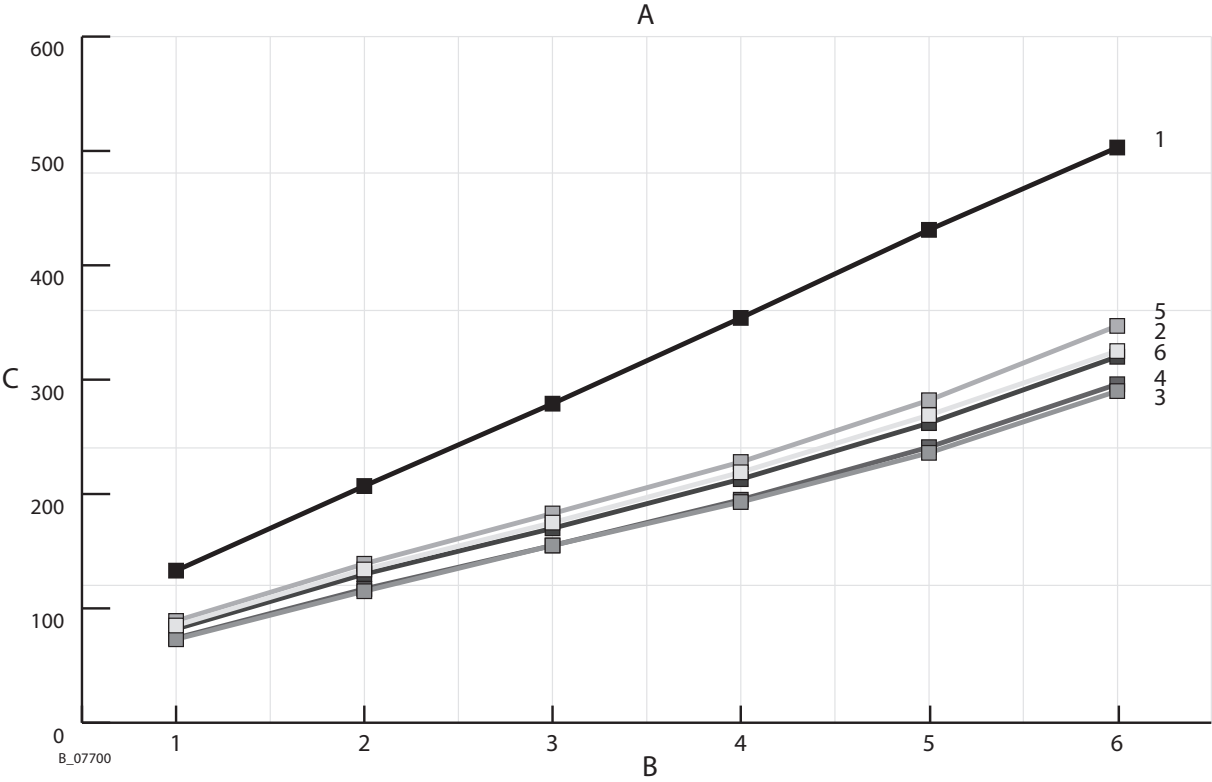

A	Atomizing air flow [AA]
B	Inlet pressure [bar]
C	Flow [nl/min]

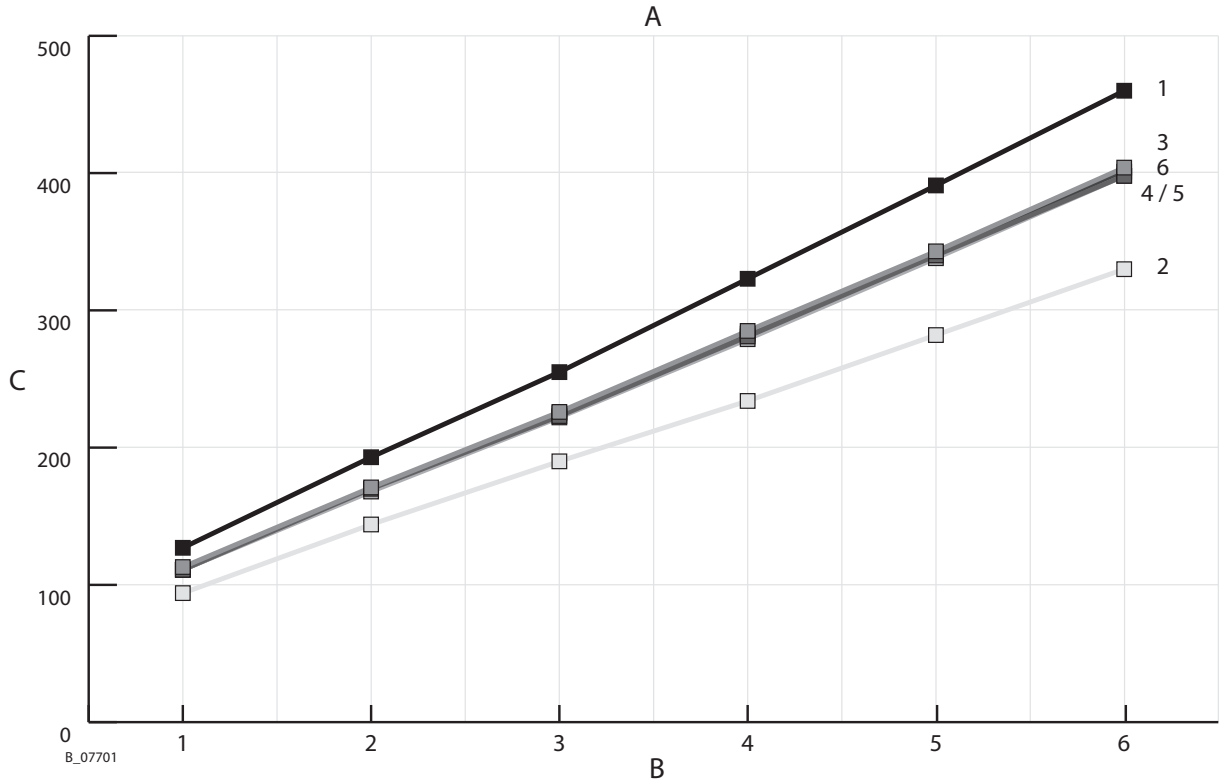

A	Shaping air flow [SA]
B	Inlet pressure [bar]
C	Flow [nl/min]

### 5.5.4 Connections

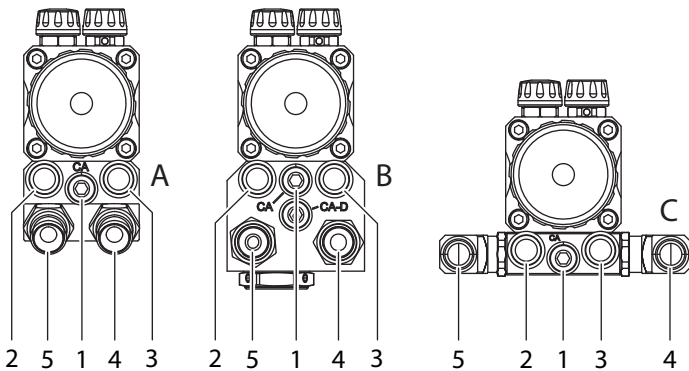
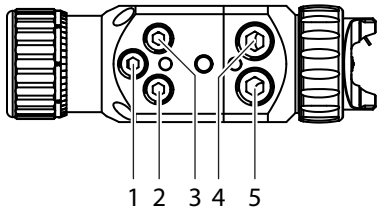

B\_07560

A	Adapter plate "Product connections at rear"
B	Adapter plate "Flushing valve"
C	Adapter plate "Product connections at side"
1	Control air connection "CA"
2	Shaping air connection "SA"
3	Atomizer air connection "AA"
4	Product connection (G 1/4") "M IN"
5	Alternative product connection circulation (G 1/4") "M OUT"

### 5.5.5 Options for Product Supply

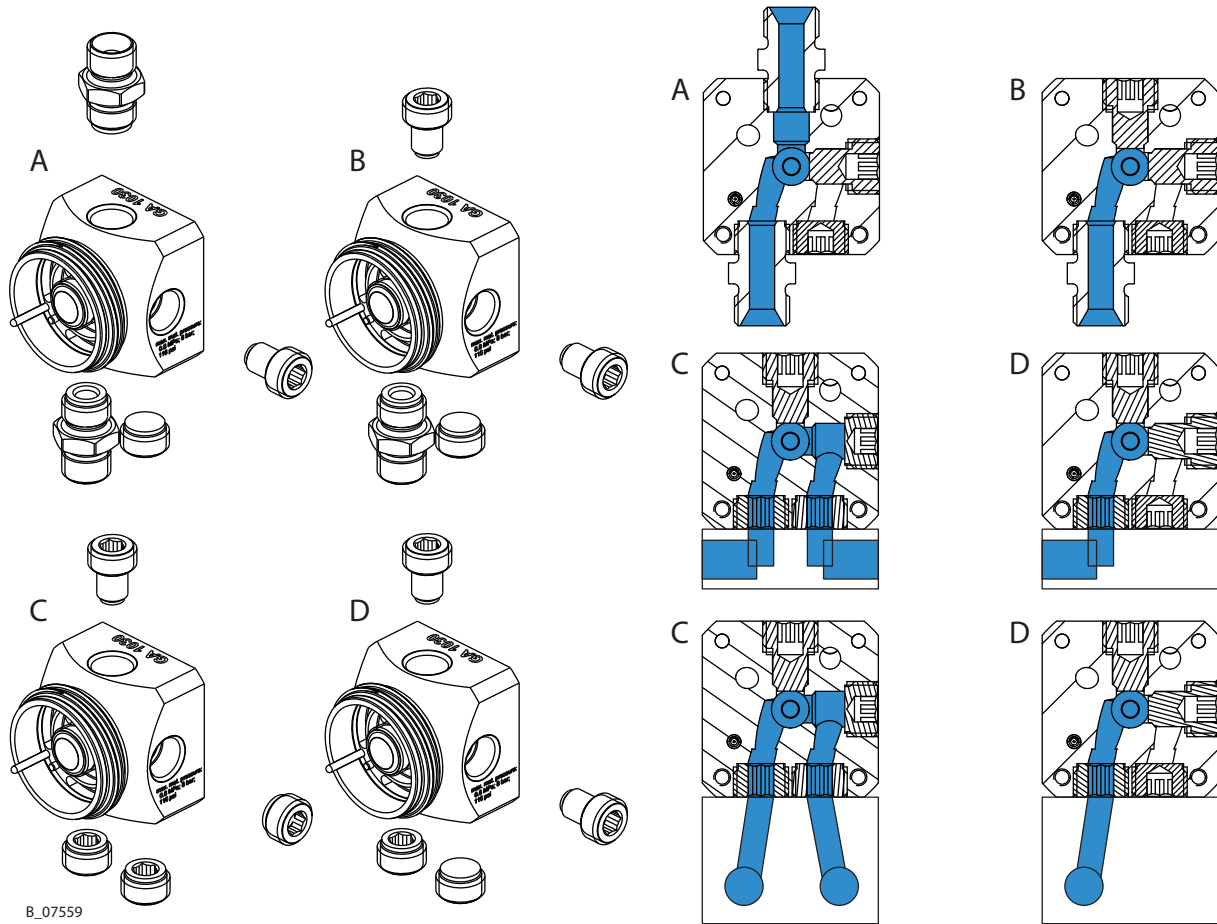

B\_07559

A	Product supply without adapter plate, with circulation.
B	Product supply without adapter plate, without circulation.
C	Product supply with adapter plate, with circulation
D	Product supply with adapter plate, without circulation

## 6 ASSEMBLY AND COMMISSIONING

### 6.1 TRAINING OF ASSEMBLY/COMMISSIONING PERSONNEL

- The assembly and commissioning personnel must have the technical skills to safely commission the device.
- When assembling, commissioning and carrying out all work, read and follow the operating manuals and safety regulations for the additionally required system components.

A skilled person must check to ensure that the device is in a reliable state after it is assembled and commissioned.

### 6.2 STORAGE CONDITIONS

Until the point of assembly, the device must be stored in a dry location, free from vibrations and with a minimum of dust. The device must be stored in closed rooms.

The air temperature at the storage location must be between -20 °C and +60 °C (-4 °F and +140 °F).

The relative air humidity at the storage location must be between 10 and 95% (without condensation).

### 6.3 INSTALLATION CONDITIONS

The air temperature at the installation site must be in a range between 0 °C and 40 °C; 32 °F and 104 °F.

The relative air humidity at the installation site must be between 10 and 95% (without condensation).

### 6.4 CONNECTING AUTOMATIC SPRAY GUN

The GA 1020/GA 1030 automatic spray gun must be combined with various components to make up a spraying system. The automatic spray gun is usually mounted using an adapter plate on the movement arm of the spraying system.

The operating manuals and safety regulations of all additional system components must be read and understood before starting with the commissioning.

#### 6.4.1 Typical Airspray Spraying System

The automatic spray gun is combined with various components to make up a spraying system. The system shown in the figure is only one example of an AirSpray spraying system.



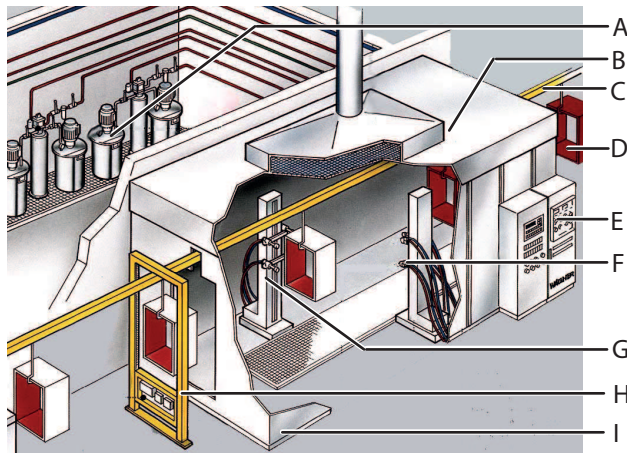

B\_00559

A	Paint supply	F	Spray guns
B	Supply air system and exhaust air system	G	Reciprocator
C	Conveyor	H	Part recognition
D	Work piece	I	Spray booth
E	Control cabinet		

#### 6.4.2 Ventilation of the Spray Booth

- ▶ Operate the device in a spray booth approved for the respective working materials.  
- or -
- ▶ Operate the unit on an appropriate spraying wall with the ventilation (extraction) switched on.
- ▶ Observe national and local regulations for the outgoing air speed.

#### 6.4.3 Air Supply Lines

##### **WARNING**

##### **Hose connections!**

Risk of injury and damage to the device.

- ▶ Do not mix up hose connections of product hose and air hose.
- ▶ Ensure that only dry, clean atomizing air is used in the spray gun! Dirt and moisture in the atomizing air worsens the spraying quality and spray pattern.



#### 6.4.4 Product Supply Lines

##### ⚠ NOTICE

###### Impurities in the spraying system

Spray gun blockage, products harden in the spraying system.

- ▶ Flush the spray gun and paint supply with a suitable flushing agent before commissioning.

##### ⚠ DANGER

###### Bursting hose, bursting threaded joints!

Danger to life from injection of product.

- ▶ Ensure that the hose material is chemically resistant to the sprayed products.
- ▶ Ensure that the spray gun, fittings and product hose between the device and the spray gun are suitable for the pressure generated in the device.
- ▶ Ensure that the following information can be seen on the high-pressure hose:
  - ▶ Manufacturer
  - ▶ Permissible operating pressure
  - ▶ Date of manufacture.



#### 6.5 GROUNDING

A conductive connection (potential equalization cable) must be established between original tank and the equipment.

1. Earth all unit components.
2. Earth the workpieces being painted.

#### 6.6 SAFETY CHECKS

- ▶ Carry out safety checks in accordance with Safety checks and maintenance intervals chapter.

#### 6.7 LACQUER PREPARATIONS

The viscosity of the lacquer is of great importance. The best spraying results are obtained with values between 25 and 150 millipascals (mPas) × sec. It is important for the optimum coating quality that the paint temperature is kept constant during coating. Further information can be found in the product's technical datasheets. Please contact your local WAGNER dealer and the lacquer manufacturer if you encounter application problems.

##### 6.7.1 Viscosity conversion table

Millipascal × sec	Centipoise	Poise	DIN cup 4 mm	ISO cup			Ford cup Number 4	Zahn cup Number 2
				4 mm	5 mm	6 mm		
mPa s	cP	P	sec	sec	sec	sec	sec	
10	10	0.1		14			5	16
15	15	0.15		17			8	17
20	20	0.2		20			10	18
25	25	0.25	14	23			12	19

Millipascal × sec	Centipoise	Poise	DIN cup	ISO cup			Ford cup	Zahn cup
			4 mm	4 mm	5 mm	6 mm	Number 4	Number 2
mPa s	cP	P	sec	sec	sec	sec	sec	sec
30	30	0.3	15	26			14	20
40	40	0.4	17	33			18	22
50	50	0.5	19	40			22	24
60	60	0.6	21	47			26	27
70	70	0.7	23	54			28	30
80	80	0.8	25	62	28		31	34
90	90	0.9	28	70	31		32	37
100	100	1	30	78	34		34	41
120	120	1.2	33	90	40		41	49
140	140	1.4	37	105	46		45	58
160	160	1.6	43		52		50	66
180	180	1.8	46		58	28	54	74
200	200	2	49		63	31	58	82
220	220	2.2	52		69	34	62	
240	240	2.4	56		75	37	65	
260	260	2.6	62		82	40	68	
280	280	2.8	65		89	43	70	
300	300	3	70		95	46	74	
320	320	3.2				48		
340	340	3.4				51		
360	360	3.6	80			54		
380	380	3.8				57		
400	400	4	90			60		

## 6.8 START UP

### 6.8.1 Preparation Before Commissioning

#### ⚠ NOTICE

##### Impurities in the spraying system

Spray gun blockage, products harden in the spraying system.

- ▶ Flush the spray gun and paint supply with a suitable flushing agent before commissioning.

### 6.8.2 Procedure

1. Correctly mount the desired paint nozzle and air cap on the automatic spray gun (see Changing the Nozzle [▶▶ 34]).
2. Mount the automatic spray gun on the matching adapter plate and the movement arm.
3. Make sure that all system components and all other conductive parts within the work area are grounded.

4. Visually check the permissible pressures (see Technical Data [▶▶ 19]) for all the system components.
5. Before commissioning, the automatic spray gun must be flushed with a solvent. Keep the flushing process as short as possible. Observe the superordinate operating manual.

### **6.8.3 Verifying a Safe Operational Condition**

A skilled person must check to ensure that the device is in a reliable state after it is assembled and commissioned.

This includes:

- Safety checks in accordance with Safety checks and maintenance intervals chapter.
- Function test, in accordance with Function test chapter, after repair work.

## 7 OPERATION

### 7.1 TRAINING THE OPERATING PERSONNEL

- The operating personnel must be qualified to operate the entire system.
- The operating staff must be familiar with the potential risks associated with improper behavior as well as the necessary protective devices and measures.
- Before work commences, the operating personnel must receive appropriate system training.

### 7.2 TASKS

Ensure that:

1. the regular safety checks are carried out in accordance with Chapter Safety Checks and Maintenance Intervals [▶▶ 33],
2. commissioning is carried out in accordance with Chapter Start up [▶▶ 27].
3. the superordinate operating manual is observed.





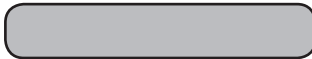

### 7.3 ADJUSTING THE SPRAY PATTERN

#### Desired spraying result

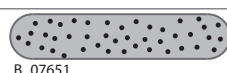

B\_06976

#### Rectifying defects in a spray pattern

spray pattern	Deviation	Required setting
 B_07653	Spray pattern is too wide in the middle	Set a wider spray shape
 B_07652	Spray pattern is too wide on the ends	Set a rounder spray shape
 B_07651	Spray pattern has very coarse droplet distribution	Increase the atomizing air pressure
 B_07654	Material application is very thin in the middle of the spray pattern	Reduce the atomizing air pressure
 B_07655	The spray pattern is divided in the middle	Increase the nozzle diameter Reduce the atomizing air pressure Increase product pressure
 B_07656	Spray pattern is too round	Reduce product pressure Increase the atomizing air pressure

#### Note:

The flow rate can be changed by:

- changing the product pressure or limiting the needle stroke,
- Use of another nozzle (see Chapters Changing the Nozzle [▶▶ 34], Nozzles [▶▶ 54], Nozzle Needle Sets for GA 1020 [▶▶ 54] and ).

### 7.3.1 Adjusting Spray Pattern

The spray pattern can be optimally adjusted to suit the object being sprayed using the shaping air regulator (1). The illustration shows the influence of the shaping air regulator (1) on the spray pattern. The spray jet can be adjusted using the atomizing air regulator (2).

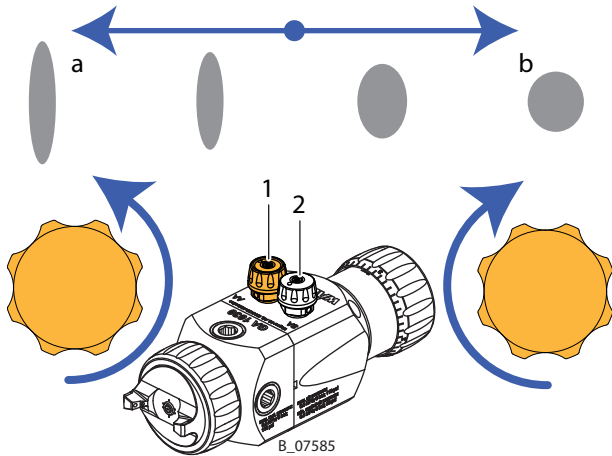

a	If the shaping air regulator (1) is rotated counterclockwise, the spray pattern is widened and increasingly oval shaped.
b	If the shaping air regulator (1) is rotated clockwise, the spray pattern is narrowed and increasingly round.

### 7.3.2 Setting the Product Flow Rate

**Note:** the desired flow rate is primarily to be specified by selecting the corresponding nozzle. The needle stroke regulator (1) only serves to make fine adjustments.

Needle stroke variant:	Procedure:
Fixed	Here, the needle is completely opened by the spring force and is controlled externally using compressed air.
Adjustable	The flow rate can be set by screwing the needle stroke regulator (1) in or out. The flow rate is increased by rotating it in a counterclockwise direction and is decreased by rotating it in a clockwise direction. The marking on the scale (2) shows the maximum needle stroke that can be set with the GA 1020 spray gun (see Chapter Distinguishing Features [▶ 18]).

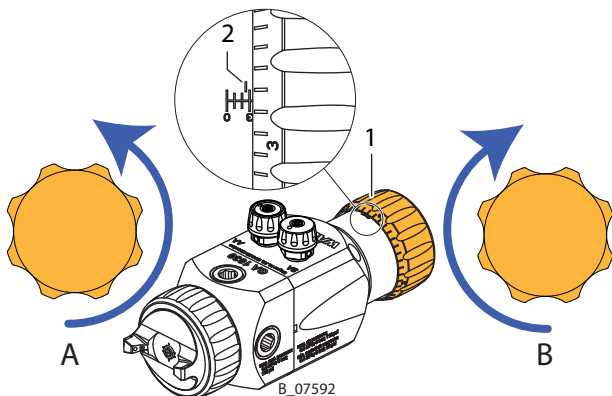

A	More product
B	Less product

#### 7.4 PRESSURE RELIEF / WORK INTERRUPTION

The pressure must always be relieved:

- after the spraying tasks are finished,
- before servicing or repairing the spraying system,
- before carrying out cleaning tasks on the spraying system,
- before something must be checked on the spraying system,
- before the nozzle is removed from the automatic spray gun.

##### **Pressure Relief Procedure:**

- ▶ Observe superordinate operating manual.

#### 7.5 BASIC FLUSHING

##### **Regular flushing**

- ▶ Regular flushing, cleaning and maintenance ensure the high spraying quality of the automatic spray gun and spraying system.
- ▶ Observe superordinate operating manual.
- ▶ The cleaning and flushing agents used must be compatible with the working material.

##### **WARNING**

##### **Incompatibility of cleaning/flushing agent and working medium!**

Risk of explosion and danger of poisoning by toxic gases.

- ▶ Examine the compatibility of the flushing and cleaning agents and working media on the basis of the safety data sheets.



## **8 CLEANING AND MAINTENANCE**

### **8.1 CLEANING**

#### **8.1.1 Cleaning Personnel**

Cleaning work should be undertaken regularly and carefully by qualified and trained personnel. They should be informed of specific hazards during their training.

The following hazards may arise during cleaning work:

- risk to health from inhaling solvent vapors,
- use of unsuitable cleaning tools and aids.

#### **8.1.2 Flushing and Cleaning the Automatic Spray Gun**

The automatic spray gun or spray system must be regularly cleaned and flushed. The cleaning/flushing agents used for cleaning or flushing must be compatible with the working material.

1. Carry out basic flushing in accordance with Chapter Basic Flushing [▶▶ 31].
2. Clean the outside of the automatic spray gun with a damp cloth.

### **8.2 MAINTENANCE**

#### **8.2.1 Maintenance Personnel**

Maintenance work should be undertaken regularly and carefully by qualified and trained personnel. They should be informed of specific hazards during their training.

The following hazards may arise during maintenance work:

- risk to health from inhaling solvent vapors,
- use of unsuitable tools and aids.

A skilled person must ensure that the device is checked for being in a reliable state after maintenance work is completed.



## 8.2.2 Safety instructions

### **DANGER**

#### **Incorrect maintenance/repair!**

Danger to life and equipment damage.

- ▶ Only a WAGNER service center or a suitably trained person may carry out repairs and replace parts.
- ▶ Use only WAGNER original spare parts and accessories.
- ▶ Only repair and replace parts that are listed in the spare parts chapter and that are assigned to the device.
- ▶ Before all work on the device and in the event of work interruptions:
  - ▶ Relieve the pressure from the spray gun, product hoses and all devices.
  - ▶ Secure the spray gun against actuation.
  - ▶ Switch off the energy and compressed air supply.
  - ▶ Disconnect the control unit from the mains.
- ▶ Observe the operating and service manual for all work.



#### **Prior to maintenance**

It should be ensured that the unit is in the following state before carrying out any work on it:

- Carry out basic flushing in accordance with Chapter Basic Flushing [▶▶ 31].
- Relieve the pressure from the spraying system, product hose and spray gun.
- Interrupt the air supply.

#### **After maintenance**

- Carry out safety checks in accordance with Chapter Safety Checks and Maintenance Intervals [▶▶ 33].
- Put the system into operation and check for leaks as described in chapter Commissioning [▶▶ 27].
- Have the system checked for safe condition by a skilled person.
- If necessary, carry out a function test in accordance with Chapter Function Test after Repair Work.

## 8.2.3 Safety Checks and Maintenance Intervals

### **Every day**

1. Check grounding: see Chapter Grounding [▶▶ 26].
2. Check hoses, tubes and couplings: see Chapter Product Hoses, Pipes and Couplings
3. Carry out basic flushing in accordance with Chapter Basic Flushing [▶▶ 31].

### **Weekly**

- ▶ Check spray guns for damage.

### **Yearly or as required**

1. In accordance with DGUV regulation 100-500, Chapters 2.29 and 2.36:
  - ▶ The liquid ejection devices should be checked by an expert (e.g., WAGNER service technician) for their safe working conditions as required and at least every 12 months.
  - ▶ For shut down devices, the examination can be suspended until the next start-up.

### 8.2.3.1 Product Hoses, Pipes and Couplings

The service life of the complete hoses between product pressure generator and application device is reduced due to environmental influences even when handled correctly.

1. Check hoses, pipes, and couplings every day and replace if necessary.
2. Before every commissioning, check all connections for leaks.
3. Additionally, the operator must regularly check the complete hoses for wear and tear as well as for damage at intervals that he/she has set. Records of these checks must be kept.
4. Replace the complete hose if one of the following two periods is exceeded:
  - ▶ 6 years from the date of the hose crimping (see fitting embossing).
  - ▶ 10 years from the date of the hose imprinting.

Fitting embossing (if present)	Meaning
xxx bar	Pressure
yymm	Crimping date (year/month)
XX	Internal code
Hose imprinting	Meaning
WAGNER	Name / manufacturer
yymm	Date of manufacture (year/month)
xxx bar (xx MPa) e.g. 270 bar (27MPa)	Pressure
XX	Internal code
DNxx (e.g., DN10)	Nominal diameter

## 8.3 CHANGING THE NOZZLE

### ⚠ NOTICE

#### Defective nozzle!

Insufficient paint application quality.

- ▶ Do not use sharp-edged objects on the carbide on the nozzle.
- ▶ Carry out basic flushing in accordance with Chapter Basic Flushing [▶▶ 31].
- ▶ Depressurization in accordance with Chapter Pressure Relief / Work Interruption [▶▶ 31].
- ▶ Clean the outside of the automatic spray gun with a damp cloth.

#### Disassembly:

**Note:** For the GA 1020 spray gun, the needle (6) is screwed on and must be loosened, but not removed, in order to change the nozzle!

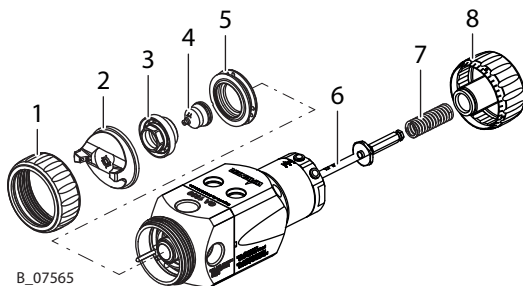

1. Unscrew the adjusting cap (8) by hand and carefully pull out the needle (6) together with the pressure spring (7).
2. Unscrew air cap nut (1) and remove air cap (2).  
**Note:** Note the position of the air manifold ring (5).
3. Unscrew nozzle nut (3) with a size 13, open-end wrench and remove nozzle (4) and air manifold ring (5).  
Treat parts with cleaning agent until all remaining paint has been dissolved.

**Assembly:**

1. **Visual control:** Check that the positioning pin (B), alignment pin, air manifold ring (5) and drilled hole in air manifold ring (5) are free of defects.
  - ▶ Insert the air manifold ring (5) in the front side. Align the groove (A) of the air manifold ring (5) with the positioning pin (B) on the front side of the body (see Disassembly, Note, step 2).

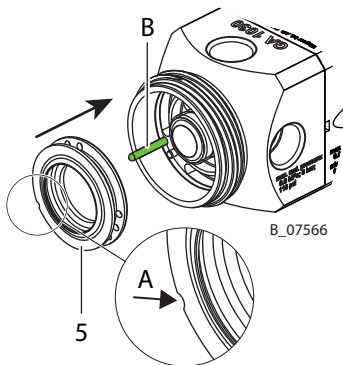

2. **Visual control:** Check that the nozzle (4) is free of defects.  
Insert nozzle (4) and tighten nozzle nut (3) with a socket wrench (size 13) with 12 Nm torque.

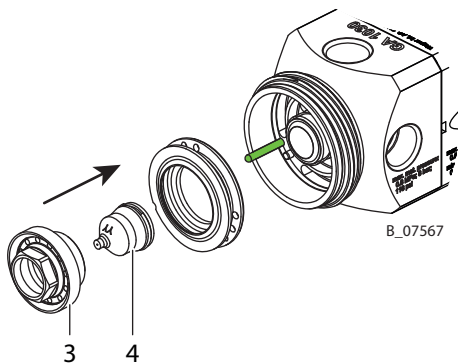

3. **Visual control:** Check that the air cap (2) is free of defects.  
Insert air cap (2).

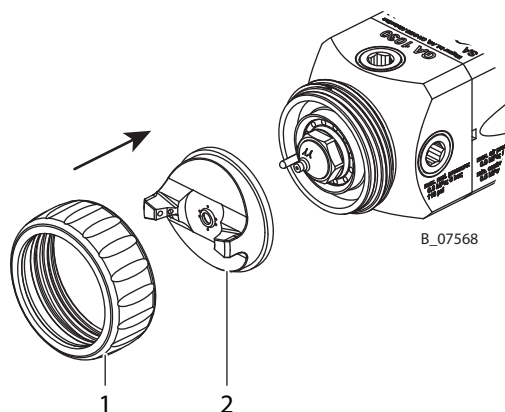

4. Put on the air cap nut (1) and tighten by hand.
5. Turn the air cap (2) to the desired position.
  - ▶ Carry out basic flushing in accordance with Chapter Basic Flushing [▶▶ 31].
  - ▶ Carry out safety checks in accordance with Chapter Safety Checks and Maintenance Intervals [▶▶ 33].
  - ▶ Put the system into operation and check for leaks as described in Chapter Start up [▶▶ 27].

#### 8.4 CHANGING THE PISTON

- ▶ Carry out basic flushing in accordance with Chapter Basic Flushing [▶▶ 31].
- ▶ Depressurization in accordance with Chapter Pressure Relief / Work Interruption [▶▶ 31].
- ▶ Clean the outside of the automatic spray gun with a damp cloth.

#### Disassembly:

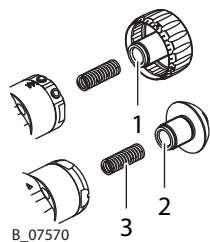

1. **Adjustable needle stroke:**  
Unscrew adjusting cap (1) from the rear side of the body and remove the pressure spring (3).
- Fixed needle stroke:**  
Unscrew lock cap (2) from the rear side of the body and remove the pressure spring (3).

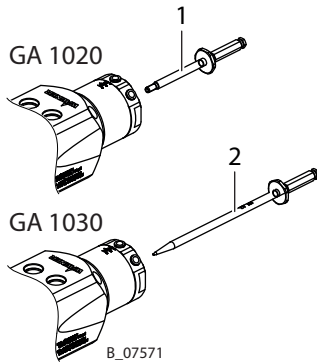

- GA 1020:**  
Unscrew rear part of needle (1) with a size 5 mm, open-end wrench.  
**GA 1030:**  
Carefully pull out needle (2) from the rear.

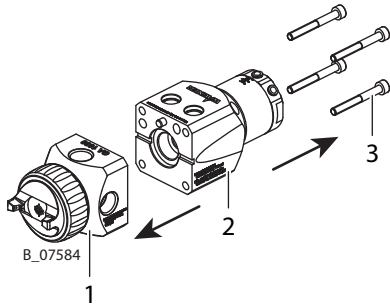

- Remove front side (1) and rear side (2) of the body using the four socket cap screws (3).

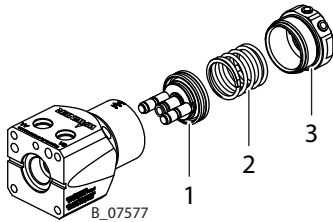

- Note:** Rear side of the body is under spring tension!  
Unscrew threaded bushing (3) with a size 32 mm, open-end wrench and remove the piston spring (2).  
Push piston (1) out through the drilled hole in the rear side of the body.

#### Assembly:

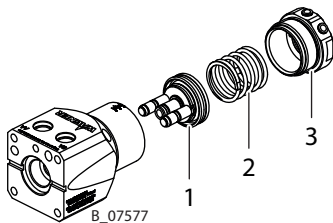

- Lightly grease the piston (1) with Vaseline and insert it into the rear side of the body.  
Grease the piston spring (2) with Molykote and insert it into the rear side of the body.  
Put on threaded bushing (3) and tighten it with a size 32, open-end wrench.

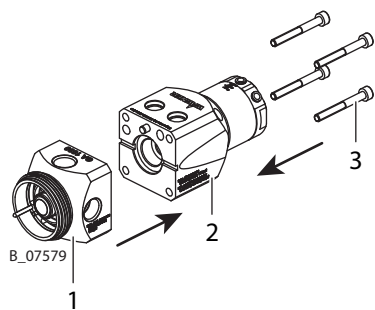

2. Screw together the front side (1) and rear side (2) of the body using the four socket cap screws (3) with a torque of 1.8 Nm.

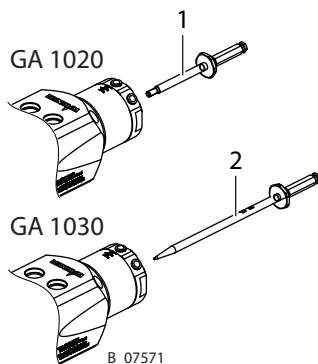

3. **GA 1020:**  
Tighten the rear part of the needle (1) by hand with a size 5 mm, open-end wrench.  
**GA 1030:**  
Lightly grease the needle (2) in the front side and carefully insert it.

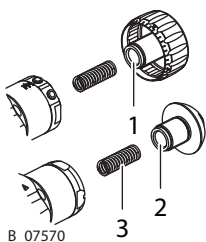

4. **Adjustable needle stroke:**  
Lightly grease the pressure spring (3) with Molykote and insert it in the adjusting cap (1). Put on the adjusting cap (1) straight and screw it in by hand until the engagement points can be felt.  
**Fixed needle stroke:**  
Lightly grease the pressure spring (3) with Molykote and insert it in the end cap (2). Then tighten the end cap with a size 15 mm, open-end wrench.
- ▶ Carry out basic flushing in accordance with Chapter Basic Flushing [▶▶ 31].
  - ▶ Carry out safety checks in accordance with Chapter Safety Checks and Maintenance Intervals [▶▶ 33].
  - ▶ Put the system into operation and check for leaks as described in Chapter Start up [▶▶ 27].

### 8.5 REPLACING THE NEEDLE PACKING (ONLY GA 1030)

- ▶ Carry out basic flushing in accordance with Chapter Basic Flushing [▶▶ 31].

- ▶ Depressurization in accordance with Chapter Pressure Relief / Work Interruption [▶▶ 31].
- ▶ Clean the outside of the automatic spray gun with a damp cloth.

**Disassembly:**

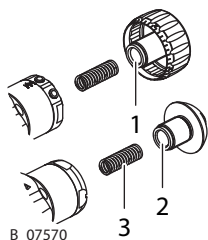

1. **Adjustable needle stroke:**

Unscrew adjusting cap (1) from rear side of the body and remove the pressure spring (3).

**Fixed needle stroke:**

Unscrew lock cap (2) from rear side of the body and remove the pressure spring (3).

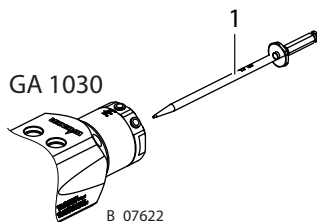

2. Carefully pull out needle (1) from the rear.

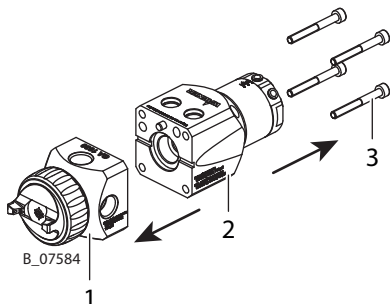

3. Remove front side (1) and rear side (2) of the body using the four socket cap screws (3).

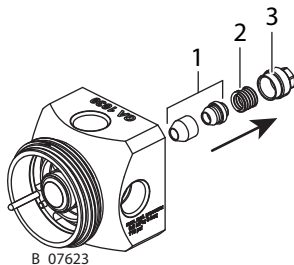

4. **Note:** Needle packing is under spring tension!

Unscrew clamping sleeve (3) with a size 7 mm, open-end wrench and remove the pressure spring (2).

Remove the front and rear parts of the needle packing (1) or carefully blow them out from the front using compressed air.

**Assembly:**

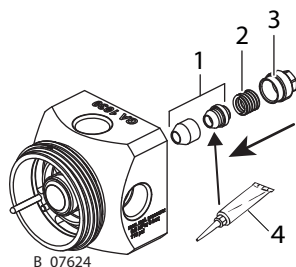

1. Lightly grease the rear needle packing (1) with Vaseline and insert it into the front side. Grease the pressure spring (2) with Molykote and place it on the rear part. Put on clamping sleeve (3) and tighten it with a size 7 mm, open-end wrench.

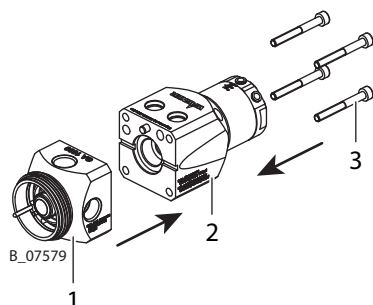

2. Screw together the front side (1) and rear side (2) of the body using the four socket cap screws (3) with a torque of 1.8 Nm.

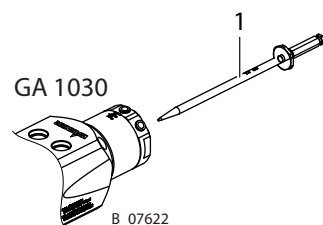

3. Lightly grease the needle (1) in the front side and carefully insert it.

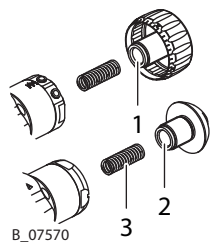

4. **Adjustable needle stroke:**  
 Lightly grease the pressure spring (3) with Molykote and insert it in the adjusting cap (1). Put on the adjusting cap (1) straight and screw it in by hand until the engagement points can be felt.

**Fixed needle stroke:**

Lightly grease the pressure spring (3) with Molykote and insert it in the end cap (2). Then tighten the end cap with a size 15 mm, open-end wrench.

- ▶ Carry out basic flushing in accordance with Chapter Basic Flushing [▶▶ 31].
- ▶ Carry out safety checks in accordance with Chapter Safety Checks and Maintenance Intervals [▶▶ 33].



- ▶ Put the system into operation and check for leaks as described in Chapter Start up [▶▶ 27].

## 8.6 CONVERTING FROM EC TO IC

The following described conversion instructions are only valid for the conversion of IC to EC. When doing so, the procedure is to remove the shaping air regulator and the atomizing air regulator and replace them with screw plugs.

Abbrevia- tion	Description
IC	Internal controller
EC	External controller

- ▶ Carry out basic flushing in accordance with Chapter Basic Flushing [▶▶ 31].
- ▶ Depressurization in accordance with Chapter Pressure Relief / Work Interruption [▶▶ 31].
- ▶ Clean the outside of the automatic spray gun with a damp cloth.

### Procedure:

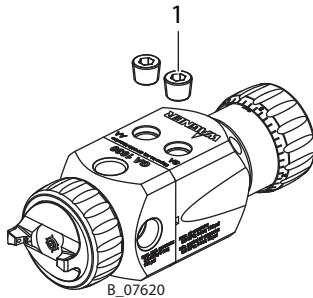

1. Unscrew sealing plugs (1) using a size 5 mm Allen wrench. If the sealing plugs are hard to unscrew, warm the sealing plugs up to approx. 150 °C to loosen the Loctite® 542 thread sealant.

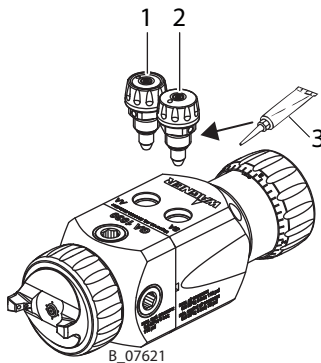

2. Coat the threads of the shaping air regulator (1) and atomizing air regulator (2) with Loctite® 542 (3). Tighten shaping air regulator (1) and atomizing air regulator (2) with a size 12 mm, open-end wrench.
  - ▶ Carry out basic flushing in accordance with Chapter Basic Flushing [▶▶ 31].
  - ▶ Carry out safety checks in accordance with Chapter Safety Checks and Maintenance Intervals [▶▶ 33].
  - ▶ Put the system into operation and check for leaks as described in Chapter Start up [▶▶ 27].

### 8.7 CONVERTING FROM A DISTRIBUTION LINE TO A CIRCUIT

- ▶ Carry out basic flushing in accordance with Chapter Basic Flushing [▶▶ 31].
- ▶ Depressurization in accordance with Chapter Pressure Relief / Work Interruption [▶▶ 31].
- ▶ Clean the outside of the automatic spray gun with a damp cloth.

**Procedure:**

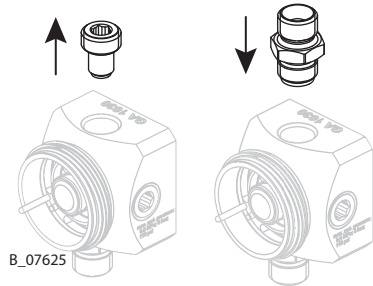

**1. Version without adapter plate**

Unscrew screw plugs using a size 5 mm Allen wrench.  
 If the sealing plugs are hard to unscrew, warm the sealing plugs up to approx. 150 °C to loosen the Loctite® 542 thread sealant.  
 Use a connection fitting instead. Coat thread with Loctite® 542 and tighten using a size 16 mm, open-end wrench.

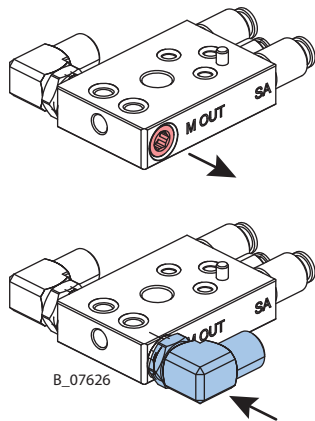

**2. Version with adapter plate:**

Unscrew sealing plugs using a size 5 mm Allen wrench.  
 Use a connection fitting instead. Coat thread with Loctite® 542 and tighten using a size 16 mm, open-end wrench.

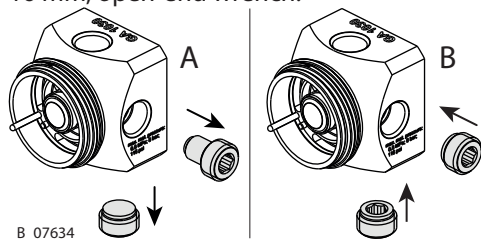

Unscrew screw plug and sealing plugs as shown (A) using a size 5 mm Allen wrench.  
 Instead, use two open G1/4" fittings, as shown (B). Coat thread with Loctite® 542 and tighten using a size 5 mm Allen wrench.

**Note:** To switch from a distribution line to circulation, the sealing plug at the connection marked with [M OUT] must be replaced with a hose connection. For the version with an adapter plate, the front part of the spray gun must also be converted accordingly (see point 2 above).

For further information on circulation and distribution lines, see Chapter 5.5.6.

- ▶ Carry out basic flushing in accordance with Chapter Basic Flushing [▶▶ 31].
- ▶ Carry out safety checks in accordance with Chapter Safety Checks and Maintenance Intervals [▶▶ 33].
- ▶ Put the system into operation and check for leaks as described in Chapter Start up [▶▶ 27].

## 9 TROUBLE SHOOTING AND SOLUTION

Functional fault	Cause	Solution
Spray gun drips	Product needle or nozzle soiled.	Clean or replace product needle or nozzle. See chapter Changing the Nozzle [▶▶ 34].
	Product needle or nozzle damaged.	Replace product needle or nozzle. See chapter Changing the Nozzle [▶▶ 34].
	Packing worn	Replace the packing, see chapter GA 1020 / 1030 automatic spray gun [▶▶ 58].
Insufficient product output	Nozzle too small	Select larger nozzle, see chapter Nozzles [▶▶ 54].
	Product pressure too low.	Increase product pressure, see chapter Technical Data [▶▶ 19].
	Nozzle clogged.	Clean or replace nozzle, see chapter Changing the Nozzle [▶▶ 34].
	Filter on product pressure generator clogged.	Clean or replace filter
	Needle stroke set too small.	Increase needle stroke by turning the adjusting screw, see chapter Setting the Product Flow Rate [▶▶ 30].
	Insufficient spray pattern	Nozzle worn.
Viscosity of material too high.		Thin the product in accordance with the manufacturer's instructions, see chapter Lacquer Preparations [▶▶ 26].
		The product temperature is too low, see chapter Technical Data [▶▶ 19].
Nozzle partially clogged.		Clean or replace nozzle, see chapter Changing the Nozzle [▶▶ 34].
The drilled holes in the air cap are damaged or clogged.		Clean or replace air cap, see chapter Changing the Nozzle [▶▶ 34].
Air cap selected incorrectly.		Use matching air cap, see chapter Air caps [▶▶ 55].
Gun does not open.	Control air too low.	Increase control air to a minimum of 5 bar.
Product leaks out of the leakage hole.	Needle packing leaky.	Only <b>GA 1030!</b> Replace the packing, see chapter Repairs [▶▶ 45].
	Diaphragm damaged.	Only <b>GA 1020!</b> Replace needle with diaphragm, see chapter Repairs [▶▶ 45].
Intermittent or fluttering spray jet	Insufficient product in product tank.	Top up product (see manufacturer operating manual).
Leaky air valve	Air valve seals not airtight.	Replace pistons with valves, see chapter Changing the Piston [▶▶ 36].

## 10 REPAIRS

### 10.1 REPAIR PERSONNEL

Repair work should be undertaken carefully by qualified and trained personnel. They should be informed of specific hazards during their training.

The following hazards may arise during repair work:

- risk to health from inhaling solvent vapors,
- use of unsuitable tools and aids.

A skilled person must check to ensure that the device is in a reliable state after it is repaired. A function test should be performed.

### 10.2 REPAIR NOTES

#### DANGER

##### **Incorrect maintenance/repair!**

Danger to life and equipment damage.

- ▶ Only a WAGNER service center or a suitably trained person may carry out repairs and replace parts.
- ▶ Use only WAGNER original spare parts and accessories.
- ▶ Only repair and replace parts that are listed in the spare parts chapter and that are assigned to the device.
- ▶ Before all work on the device and in the event of work interruptions:
  - ▶ Relieve the pressure from the spray gun, product hoses and all devices.
  - ▶ Secure the spray gun against actuation.
  - ▶ Switch off the energy and compressed air supply.
  - ▶ Disconnect the control unit from the mains.
- ▶ Observe the operating and service manual for all work.



#### **Before Repair Work**

- ▶ Carry out basic flushing in accordance with Chapter Basic Flushing [▶▶ 31].
- ▶ Depressurization in accordance with Chapter Pressure Relief / Work Interruption [▶▶ 31].
- ▶ Clean the outside of the automatic spray gun with a damp cloth.

#### **After Repair Work**

- ▶ Carry out safety checks in accordance with Chapter Safety Checks and Maintenance Intervals [▶▶ 33].
- ▶ Put the system into operation and check for leaks as described in Chapter Start up [▶▶ 27].
- ▶ Have the system checked for safe condition by a skilled person.
- ▶ Function test in accordance with Chapter Function Test after Repair Work.

### 10.3 TOOLS

The following tools are required for carrying out the repair work on the gun described below:

- Open-end wrench sizes 5 mm; 7 mm; 12 mm\*; 13 mm; 15 mm\*\*\*; 16 mm\*; 19 mm\*\*
- Allen wrench sizes 3mm; 5mm; 6mm\*

\* Only for converting to another configuration (not for service)

\*\* Only GA 1020 automatic spray guns

\*\*\* Without needle stroke adjustment - **Assembly aids:**

Order no.	Quantity	Designation	Smaller tanks
9992831	1 pc = 50 ml	Loctite <sup>®</sup> 542	
9992590	1 pc = 50 ml	Loctite <sup>®</sup> 222	
9992616	1 pc = 1 kg can	Molykote <sup>®</sup> DX grease	50 g tube = Order no. 2355419
9992698	1 pc = 200 g	Vaseline white, PHHV II	

**Brand notice:**

The brands specified in this document are property of the respective owners. Loctite<sup>®</sup>, for example, is a registered brand of Henkel.

**10.4 DISASSEMBLY**

- ▶ Carry out basic flushing in accordance with Chapter Basic Flushing [▶▶ 31].
- ▶ Depressurization in accordance with Chapter Pressure Relief / Work Interruption [▶▶ 31].
- ▶ Clean the outside of the automatic spray gun with a damp cloth.

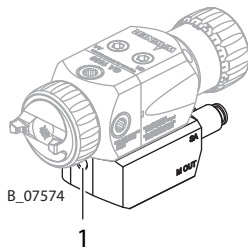

1. Loosen grub screw (1) with a size 3 mm Allen wrench.  
Remove the automatic spray gun from the connection plate.

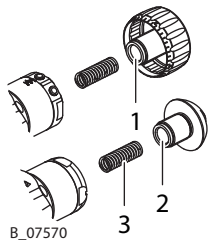

2. **Adjustable needle stroke:**  
Unscrew the adjusting cap (1) from the rear side of the body and remove the pressure spring (3).

**Fixed needle stroke:**

Unscrew locking cap (2) from the rear side of the body and remove the pressure spring (3).

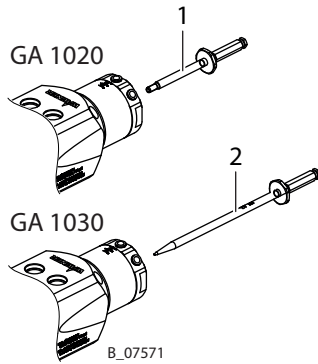

3. **GA 1020:**  
Unscrew rear part of needle (1) with a size 5 mm, open-end wrench.
- GA 1030:**  
Carefully pull out needle (2) from the rear.

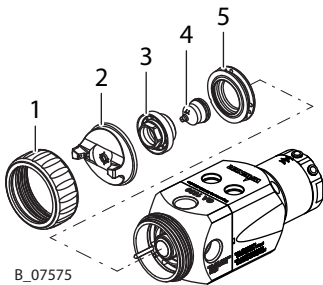

4. Unscrew air cap nut (1) and remove air cap (2).  
**Notice:**Note the position of the air manifold ring (5).
5. Unscrew nozzle nut (3) with a size 13, open-end wrench and remove nozzle (4) and air manifold ring (5).  
Treat parts with cleaning agent until all remaining paint has been dissolved.

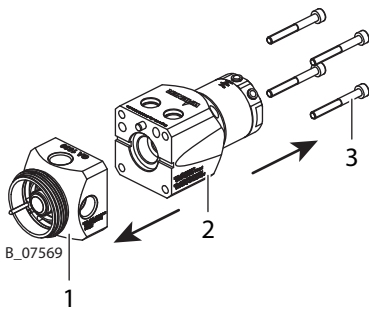

6. Remove front side (1) and rear side (2) of the body using the four socket cap screws (3).

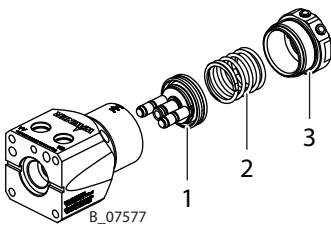

7. **Note:**The rear side of the body is under spring tension!  
Unscrew threaded bushing (3) with a size 32 mm, open-end wrench and remove the piston spring (2).  
Push out piston (1) through the drilled hole in the rear side of the body.

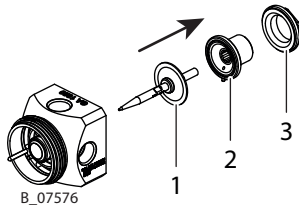

8. **Only GA 1020:**

Unscrew clamping nut (3) with a size 19 mm, open-end wrench from the front side of the body and pull out the needle guide (2) together with the needle diaphragm (1).

### 10.5 ASSEMBLY

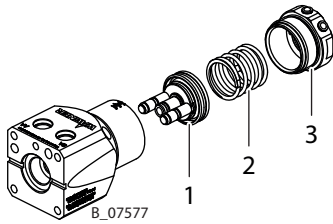

1. Lightly grease the piston (1) with Vaseline and insert it into the rear side of the body. Grease the piston spring (2) with Molykote and insert it into the rear side of the body. Put on threaded bushing (3) and tighten it with a size 32, open-end wrench.

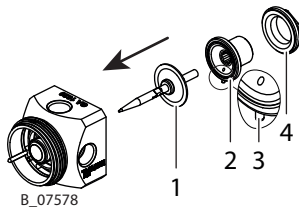

2. **Only GA 1020:**

Lightly grease the needle (1) with Molykote DX. Insert needle (1) in needle guide (2). Insert together in the front side of the body. Ensure the correct alignment of the positioning pin (3) with the front side of the body! Place clamping nut (4) on front side of body and tighten with 5 Nm torque. Check if the needle can be moved!

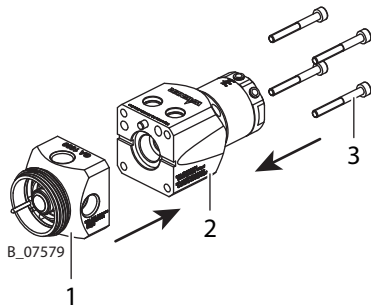

3. Screw together the front side (1) and rear side (2) of the body using the four socket cap screws (3) with a torque of 1.8 Nm.



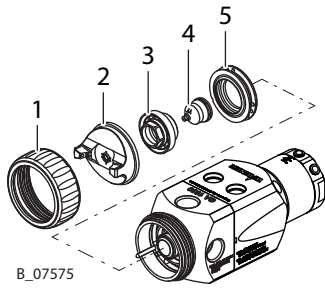

B\_07575

4. Insert the air manifold ring (5) in the spray gun and, when doing so, ensure the correct alignment. Insert nozzle (4). Lightly grease the nozzle nut (3) with Molykote DX and tighten it with a size 13, open-end wrench and a torque of 12 Nm.
5. Mount air cap (2) and air cap nut (1). Tighten the air cap (1) by hand.

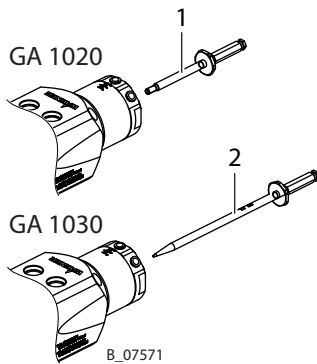

B\_07571

6. **GA 1020:**  
Tighten the rear part of the needle (1) by hand with a size 5 mm, open-end wrench.  
**GA 1030:**  
Carefully insert the needle (2).

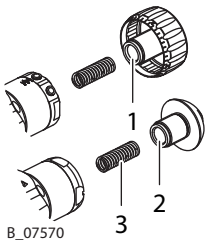

B\_07570

7. **Adjustable needle stroke:**  
Insert the pressure spring (3) in the adjusting cap (1) and put on the adjusting cap (1) straight and screw it in by hand until the engagement points can be felt.  
**Fixed needle stroke:**  
Insert the pressure spring (3) in the end cap (2) and tighten the end cap with a size 15 mm, open-end wrench.  
**Visual check:**  
Check that the connection plate and the automatic spray gun are free of defects. Ensure that there are no foreign bodies in the supply line. Contamination of the conveyed product leads to a diminishing of the automatic spray gun's service life.

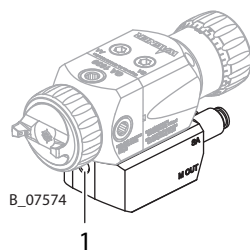

8. Position the automatic spray gun on the connection plate and mount it using M6 x 12 mm (1) hexagon socket screw.
  - ▶ Carry out basic flushing in accordance with Chapter Basic Flushing [▶▶ 31].
  - ▶ Carry out safety checks in accordance with Chapter Safety Checks and Maintenance Intervals [▶▶ 33].
  - ▶ Put the system into operation and check for leaks as described in Chapter Start up [▶▶ 27].

## 10.6 SUPPORTING BAR ASSEMBLY

### 10.6.1 On Spray Gun

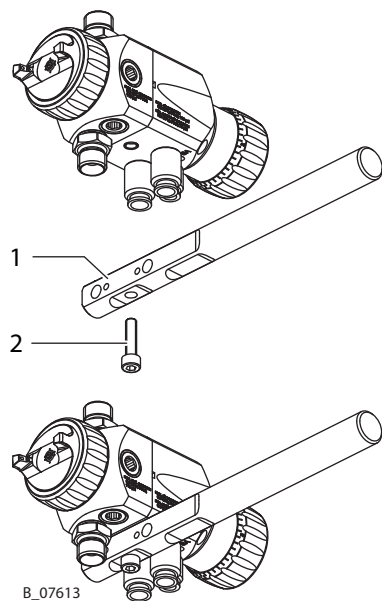

1. Turn/align supporting bar (1) as shown.
2. Fasten supporting bar (1) to the spray gun with the supplied hexagon socket screw (2).

### 10.6.2 On Adapter Plate

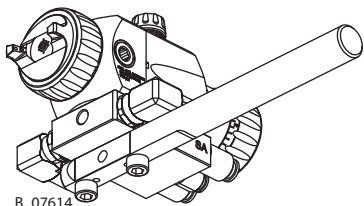
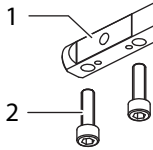
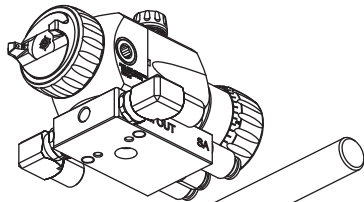

B\_07614

1. Turn/align supporting bar (1) as shown.
2. Fasten supporting bar (1) to the adapter plate with the supplied hexagon socket screw (2).

## 11 FUNCTION TEST AFTER REPAIR WORK

After all repair work, the spray gun must be checked for safe condition before recommissioning. The necessary scope of inspection and testing depends on the repair carried out and must be documented by the repair personnel.

Activity	Aid tools
<b>1. Assembly inspection</b>	
▶ Automatic spray gun correctly mounted on robot arm?	Visual inspection
<b>2. Tightness check</b>	
1. Product and air hose may not be damaged. 2. Product hose and air hose must be properly connected.	Visual inspection Air max. 8 bar GA 1020: product max. 2.5 bar GA 1030: product max. 8 bar
<b>3. Function test</b>	
1. Valve needle (opens and closes correctly). 2. Atomizer and air cap are clean. 3. There is horn and atomizing air.	Visual inspection

## **12 DISPOSAL**

When the devices must be scrapped, please differentiate the disposal of the waste materials.

The following materials have been used:

- Stainless steel
- Aluminium
- Brass
- Plastics

The consumable products (lacquers, adhesives, solvents) must be disposed of in accordance with the applicable specific standards.

## 13 ACCESSORIES

### 13.1 NOZZLES

Order no.	Description	Illustration
2404486	Nozzle 0.3 mm	 B_07137
2404487	Nozzle 0.5 mm	
2404488	Nozzle 0.8 mm	
2404489	Nozzle 1.0 mm	
2404491	Nozzle 1.2 mm	
2404492	Nozzle 1.5 mm	
2404493	Nozzle 1.8 mm	
2404494	Nozzle 2.0 mm	
2404495	Nozzle 2.2 mm	
2404496	Nozzle 2.5 mm	
2404497	Nozzle 3.0 mm	
2404498	Nozzle 3.5 mm	

### 13.2 NOZZLE NEEDLE SETS FOR GA 1020

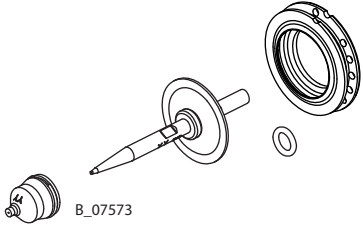
Order no.	Description	Illustration
2407284	GA 1020 nozzle needle set 0.3 mm	 B_07573
2407285	GA 1020 nozzle needle set 0.5 mm	
2407286	GA 1020 nozzle needle set 0.8 mm	
2407287	GA 1020 nozzle needle set 1.0 mm	
2407288	GA 1020 nozzle needle set 1.2 mm	
2407289	GA 1020 nozzle needle set 1.5 mm	
2407290	GA 1020 nozzle needle set 1.8 mm	
2407291	GA 1020 nozzle needle set 2.0 mm	

### 13.3 NOZZLE NEEDLE SETS FOR GA 1030

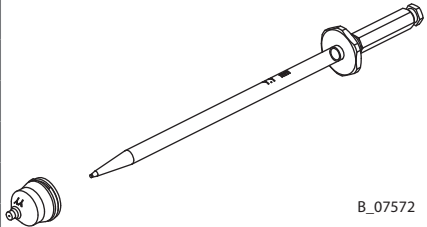
Order no.	Description	Illustration
2407264	GA 1020 nozzle needle set 0.3 mm	 B_07572
2407265	GA 1020 nozzle needle set 0.5 mm	
2407266	GA 1020 nozzle needle set 0.8 mm	
2407267	GA 1020 nozzle needle set 1.0 mm	
2407268	GA 1020 nozzle needle set 1.2 mm	
2407269	GA 1020 nozzle needle set 1.5 mm	
2407270	GA 1020 nozzle needle set 1.8 mm	
2407271	GA 1020 nozzle needle set 2.0 mm	
2407272	GA 1020 nozzle needle set 2.2 mm	
2407281	GA 1020 nozzle needle set 2.5 mm	
2407282	GA 1020 nozzle needle set 3.0 mm	
2407283	GA 1020 nozzle needle set 3.5 mm	





### 13.4 AIR CAPS

Order no.	Description		
2401161	Air cap 0.3-1.8 mm CONV 8	Top coat, clear lacquer, separating agent, anti-dust	 B_07078
2401165	Air cap 2.0-2.5 mm CONV 8		
2401166	Air cap 3.0 mm CONV 8		
2401167	Air cap 3.5 mm CONV 8		
2401168	Air cap 0.3-1.8 mm CONV 10	Stain, primer, filler, top coat, clear lacquer, spraying plaster, separating agent	 B_07078
2401169	Air cap 2.0-2.5 mm CONV 10		
2401170	Air cap 3.0 mm CONV 10		
2401171	Air cap 3.5 mm CONV 10		
2401172	Air cap 0.3-1.8 mm CONV 12	Top coat, clear lacquer, separating agent	 B_07078
2401173	Air cap 2.0-2.5 mm CONV 12		
2401174	Air cap 0.3-1.8 mm CONV 14	Top coat, clear lacquer, separating agent, anti-dust	 B_07078
2401175	Air cap 2.0-2.5 mm CONV 14		
2401176	Air cap 0.3-1.8 mm HVLP Plus	Stain, primer, filler, base lacquer, top coat, clear lacquer, glaze	 B_07079
2401177	Air cap 2.0-2.5 mm HVLP Plus		
2401178	Air cap 3.0 mm HVLP Plus		
2401179	Air cap 3.5 mm HVLP Plus		
2401180	Air cap 0.3-1.8 mm HVLP	Stain, primer, filler, base lacquer, top coat, glazes, spraying plaster	 B_07080
2401181	Air cap 2.0-2.5 mm HVLP		
2401182	Air cap 3.0 mm HVLP		
2401183	Air cap 3.5 mm HVLP		

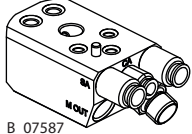
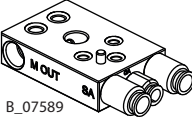
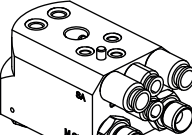
**General application areas:** wood, general industry, metal, glass, plastic

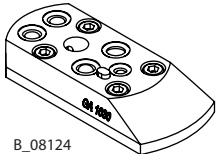
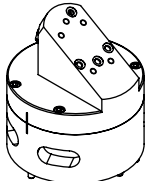
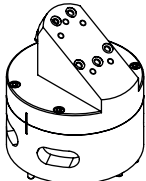
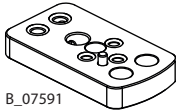
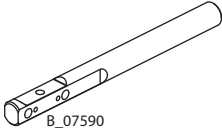
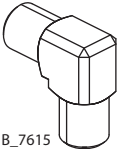
### 13.5 CONNECTION PLATE AND ADAPTER

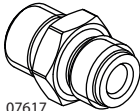
Order no.	Designation	
2407164	<b>GA 1020/1030 adapter plate (aluminium, nickel-plated)</b> With connections, for with or without internal control with or without circulation	 B_07587
2407163	<b>GA 1020/1030 adapter plate (stainless steel)</b> With air connections, without elbow, for with or without internal control With or without circulation	 B_07589
2410060	<b>GA 1020/1030 adapter plate with flushing valve</b> 0° base plate with fittings, can be used with or without circulation	 B_07588

Order no.	Designation	
2426691	<b>Complete adapter plate for GA 1030</b> To complete the GA 1030 robot adapter for distribution base or circulation base	 B_08124
2411634	<b>GA 1020/1030 gun adapter for TF Robot Bell 1</b> with optical fibre cable adaption	
2425806	<b>60° adapter for distribution base robot applications</b> With integrated flushing valve, for Fanuc P 250i in general for 2K products Product can be dumped and flushed in the adapter, upstream of the gun. Complete GA 1030 adapter plate is necessary	 B_08122
2425806	<b>60° adapter for circulation base robot applications</b> With integrated flushing valve, for Fanuc P 250i in general for 2K products Product can be dumped and flushed in the adapter, upstream of the gun. Complete GA 1030 adapter plate is necessary	 B_08123
2409620	<b>GA 1020/1030 adapter plate for AGMD 517/PaintPro</b> Intermediate plate for exchange with same TCP	 B_07591
2409636	<b>Holder for gun or base plate</b> including fastening screws	 B_07590
V2190020003	<b>90° product connection</b>	 B_7615
V2190016000	<b>Nut</b>	 B_07616
2406685	<b>Straight product connection for stainless steel adapter plate</b>	 B_07617
2394499	<b>G1/4" sealing plugs</b>	 B_07618



## 14 SPARE PARTS

### DANGER

#### **Incorrect maintenance/repair!**

Danger to life and equipment damage.

- ▶ Only a WAGNER service center or a suitably trained person may carry out repairs and replace parts.
- ▶ Use only WAGNER original spare parts and accessories.
- ▶ Only repair and replace parts that are listed in the spare parts chapter and that are assigned to the device.
- ▶ Before all work on the device and in the event of work interruptions:
  - ▶ Relieve the pressure from the spray gun, product hoses and all devices.
  - ▶ Secure the spray gun against actuation.
  - ▶ Switch off the energy and compressed air supply.
  - ▶ Disconnect the control unit from the mains.
- ▶ Observe the operating and service manual for all work.



### 14.1 HOW TO ORDER SPARE PARTS

Always supply the following information to ensure delivery of the right spare part:

#### **Order number, designation and quantity**

The quantity need not be the same as the number given in the quantity column „Stk“ on the list. This number merely indicates how many of the respective parts are used in each component.

The following information is also required to ensure smooth processing of your order:

- billing address
- delivery address
- name of the person to be contacted in the event of any queries
- type of delivery (normal mail, express delivery, air freight, courier etc.)

#### **Identification in spare parts lists**

Explanation of column „K“ (marking) in the following spare parts lists:

◆ Wearing parts. Wearing parts are not included in the warranty.

★ = included in service set

● not part of the standard equipment but available as a special accessory

Explanation of order no. column:

- Item not available as spare part.
- / Position does not exist.

### 14.2 GA 1020 / 1030 AUTOMATIC SPRAY GUN

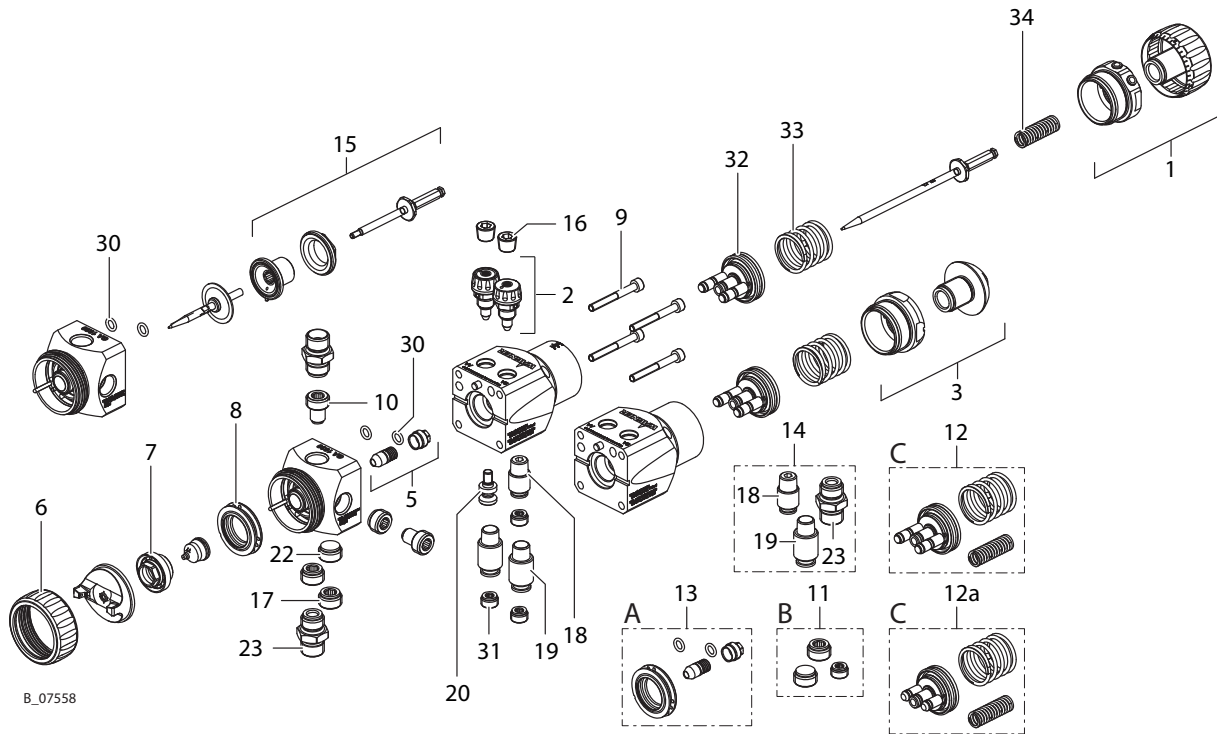

Pos	K	Stk	Order no.	Designation	A	B	C
1		1	2407259	Needle stroke adjustment set			
2		1	2407244	Air regulator set			
3		1	2407261	Constant needle stroke set			
5	◆ *	1	2400771	Needle packing set	x		
6	◆	1	2400769	Air cap nut, cpl.			
7		1	2400782	Nozzle nut			
8	◆ *	1	2400779	Air control ring	x		
9		4	K158.03	Hexagon socket head cap screw			
10		1	2398075	G1/4 product connections plugs			
14	◆	1	2411643	Fitting set, assembly without adapter			
15	◆	1	2407258	Needle guide, diaphragm			
16		2	2324032	Fitting PF-M-R1/8-530 bar-SSt			
17	*	3	2394644	G1/4 fitting, open		x	
18		1	V6610153013	Push-in fitting, QS-1/8-6-l			
19		2	V6610153015	Push-in fitting_QS-1/8-8-l			
20		1	2404903	Fixing bolt			
21			2363204	Threaded pin with hex. socket/point			
22	*		2394499	G1/4" sealing plugs		x	
23			2406685	Fitting, DF-MM-G1/4-G1/4-SSt			
30	*		--	O-ring	x		
31	*		--	Sealing plug		x	

Pos	K	Stk	Order no.	Designation	A	B	C
32	*		--	Piston			x
33	*		--	Piston spring			x
34	*		--	Needle spring			x

◆ = Wearing part.

\* = included in service set

● = not part of the standard equipment but available as a special accessory

#### Tool and service set

Pos	K	Stk	Order no.	Designation	A	B	C
13	◆	1	2407254	GA 1030 service set (O-ring, needle packing set)	A		
11		1	2407240	Adapter fittings set		B	
12	◆	1	2407247	Service set - pistons			C
12a	◆	1	2411646	Service set - pistons without valves			C
		1	2407165	Adapter plate seal set (O-rings)			
		1	2411643	Fitting set, assembly without adapter			

◆ = Wearing part.

\* = included in service set

● = not part of the standard equipment but available as a special accessory

#### 14.2.1 Adapter plate "Product connections at side"

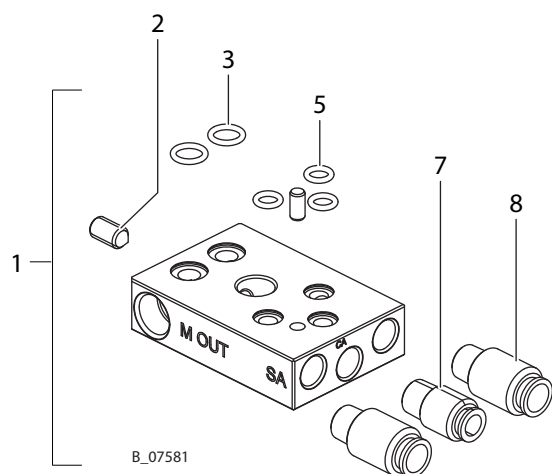

Pos	K	Stk	Order no.	Designation
1		1	2407163	Adapter plate "Product connections at side"
2		1	2363204	Threaded pin with hex. socket/point
3	◆ *	2	--	O-ring
5	◆ *	3	--	O-ring
7		1	V6610153013	Push-in fitting, QS-1/8-6-I
8		2	V6610153015	Push-in fitting, QS-1/8-8-I

**Note:** The O-rings are only available in a set (order no. 2407165).

### 14.2.2 Adapter plate "Product connections at rear"

#### ! NOTICE

The O-rings are only available in a set (order no. 2407165).

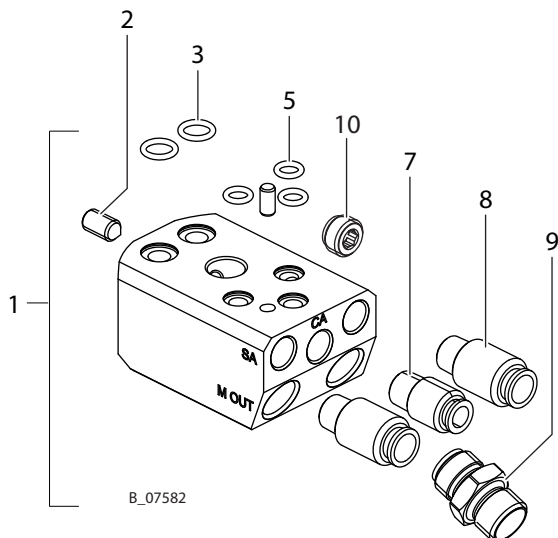

Pos	K	Stk	Order no.	Designation
1		1	2407164	Adapter plate "Product connections at rear"
2		1	2363204	Threaded pin with hex. socket/point
3	◆ *	2	--	O-ring
5	◆ *	3	--	O-ring
7		1	V6610153013	Push-in fitting, QS-1/8-6-I
8		2	V6610153015	Push-in fitting, QS-1/8-8-I
9		2	2406685	Fitting, DF-MM-G1/4-G1/4-SSt
10			2394499	Sealing plug

### 14.2.3 Adapter plate "Flushing valve"

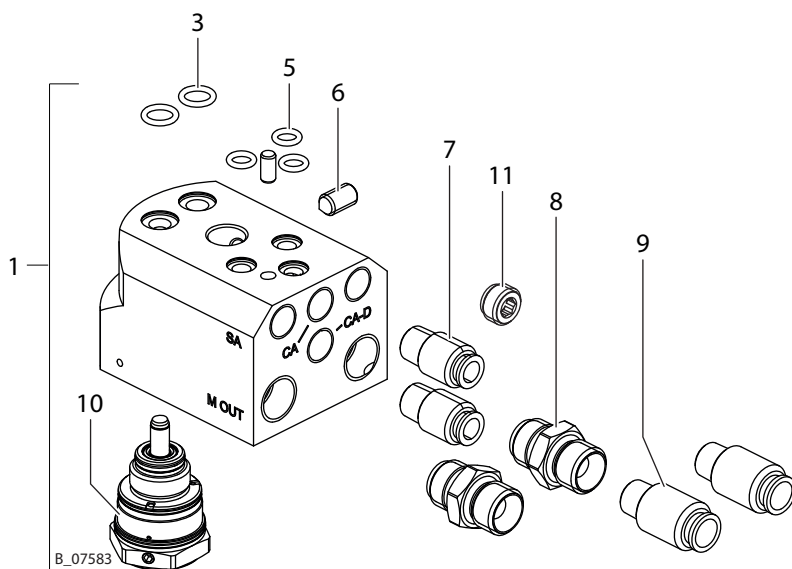

Pos	K	Stk	Order no.	Designation
1		1	2410060	Adapter plate "Flushing valve"
3	◆ *	2	--	O-ring
5	◆ *	3	--	O-ring
6		1	2363204	Threaded pin with hex. socket/point
7		2	V6610153013	Push-in fitting, QS-1/8-6-l
8		2	2406685	Fitting, DF-MM-G1/4-G1/4-SSt
9		2	V6610153015	Push-in fitting, QS-1/8-8-l
10		1	2342424	Needle valve
11			2394499	Sealing plug

**Note:** The O-rings are only available in a set (order no. 2407165).

## 15 EU DECLARATION OF CONFORMITY

Herewith we declare that the supplied version of the:

**GA 1020/GA 1030** automatic spray gun  
complies with the following guidelines:

2006/42/EC
2014/34/EU

Applied standards, in particular:

EN ISO 12100:2010	EN 14462:2015
EN 1953:2013	EN 1127-1:2011
EN ISO 13732-1:2008	EN ISO 80079-36:2016

Applied national technical standards and specifications, in particular:

DGUV regulation 100-500 Chapter 2.29
DGUV regulation 100-500 Chapter 2.36
TRGS 727

**Identification:**   II 2G X

### EU Declaration of Conformity

The EU Declaration of Conformity is enclosed with this product. If needed, further copies can be ordered through your WAGNER dealer by specifying the product name and serial number.

**Order number:** 2407800



The logo features a black triangle above the word "WAGNER" in a bold, black, sans-serif font, all set against a yellow rectangular background.

Order number 2407555  
Edition 07/2021

**Germany**

J. Wagner GmbH  
Otto-Lilienthal-Strasse 18  
Postfach 1120  
D-88677 Markdorf  
Telephone: +49 (0)7544 5050  
Fax: +49 (0)7544 505200  
E-mail: [ts-liquid@wagner-group.com](mailto:ts-liquid@wagner-group.com)

**Switzerland**

Wagner International AG  
Industriestrasse 22  
CH-9450 Altstätten  
Telephone: +41 (0)71 757 2211  
Fax: +41 (0)71 757 2222

Document number 11381503  
Version C



More contact addresses on the internet at:  
[www.wagner-group.com](http://www.wagner-group.com)

Subject to changes without notice