

# WAGNER

## FinishControl 3500

操作手册

1

Operating manual

13

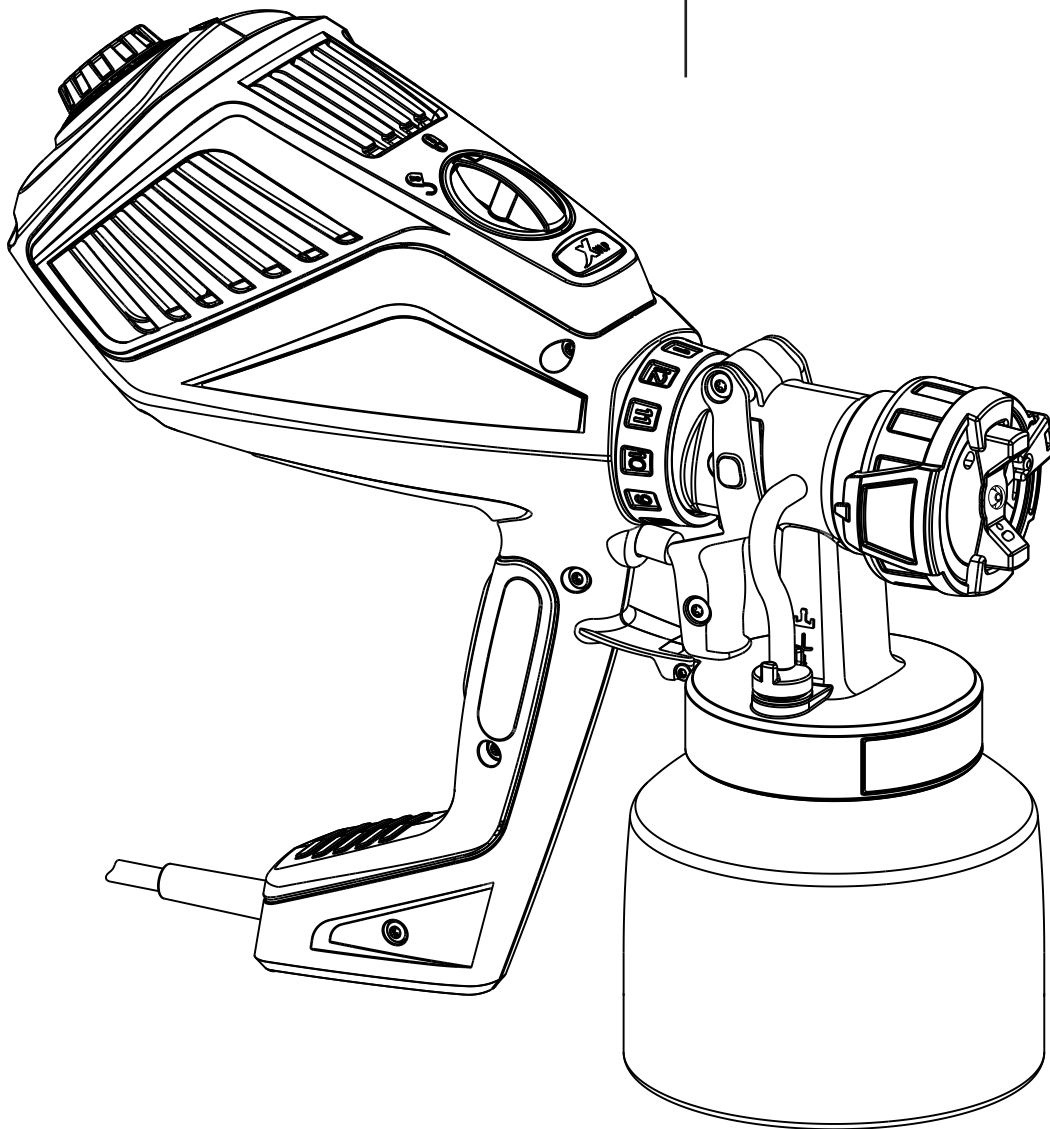

2360263

07 / 2015



© Copyright by J.Wagner GmbH

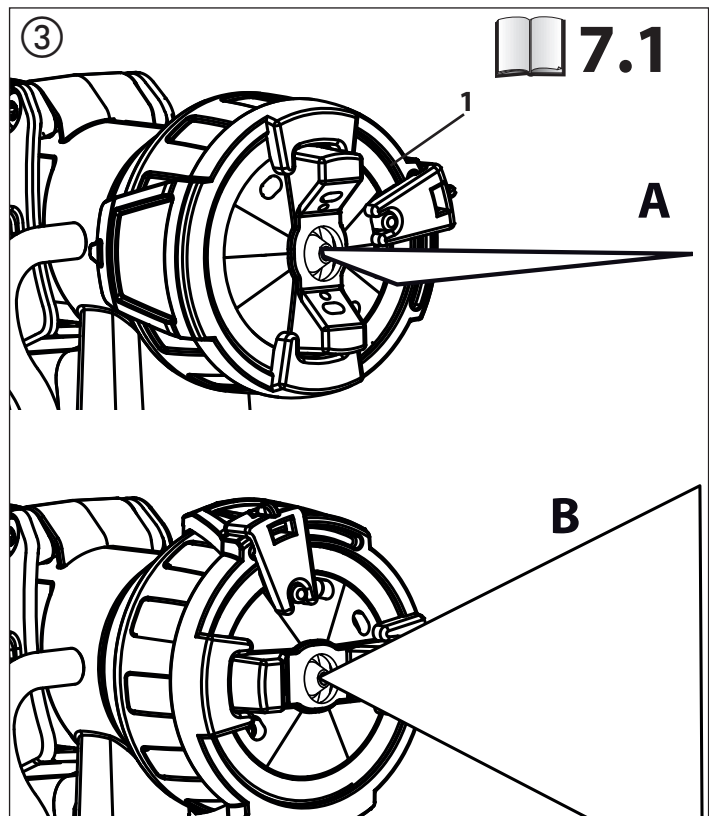
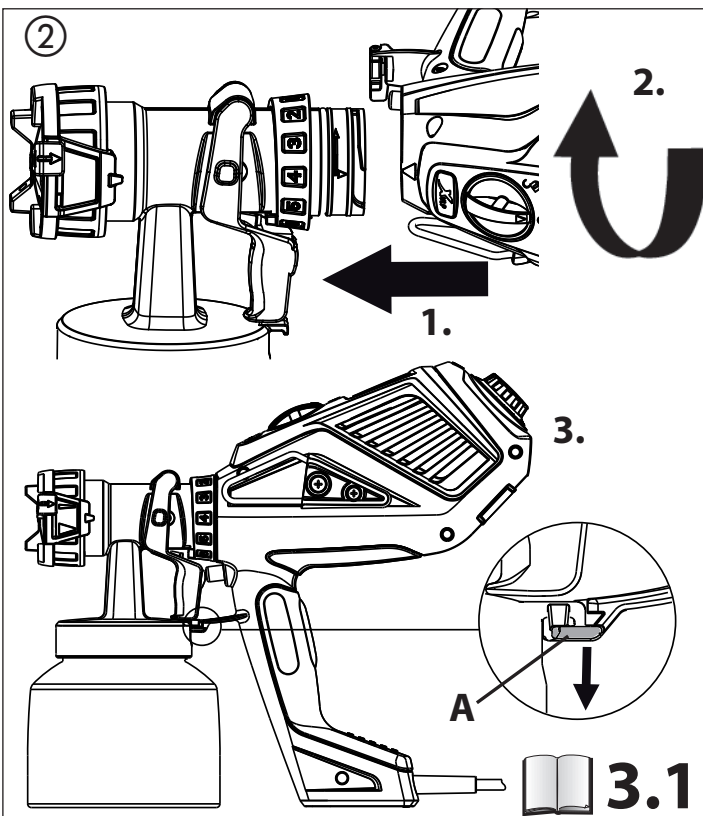
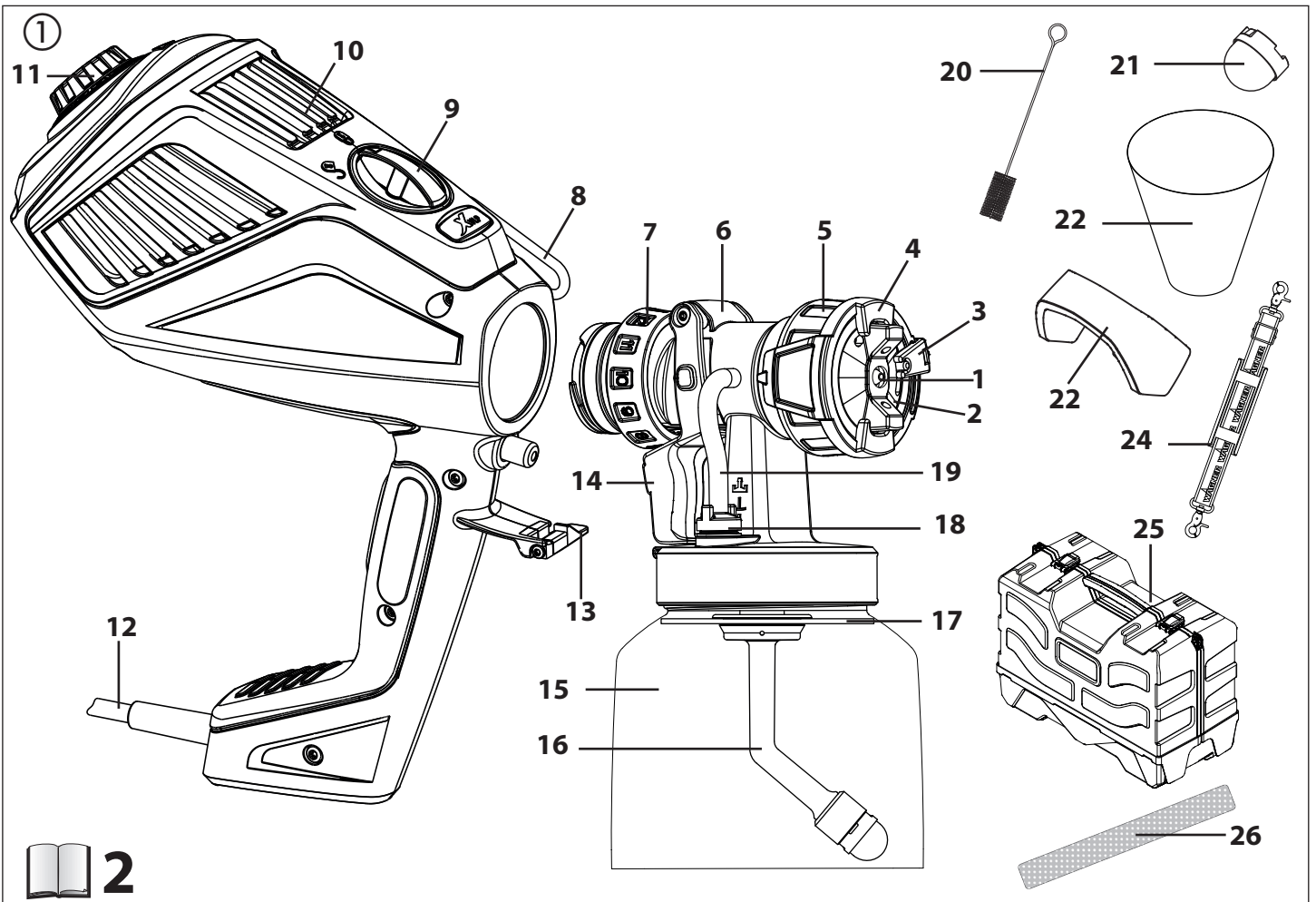

# FinishControl 3500

**WAGNER**

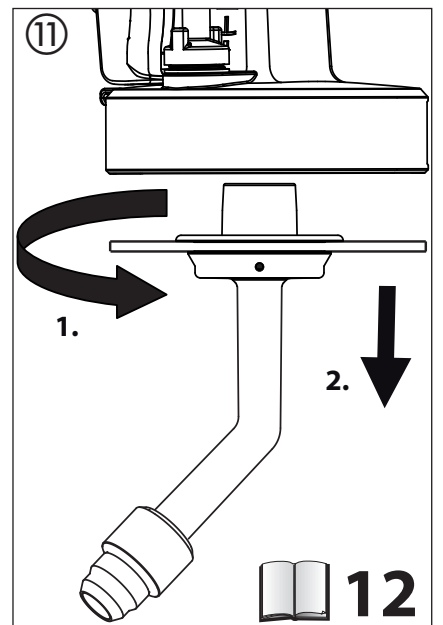
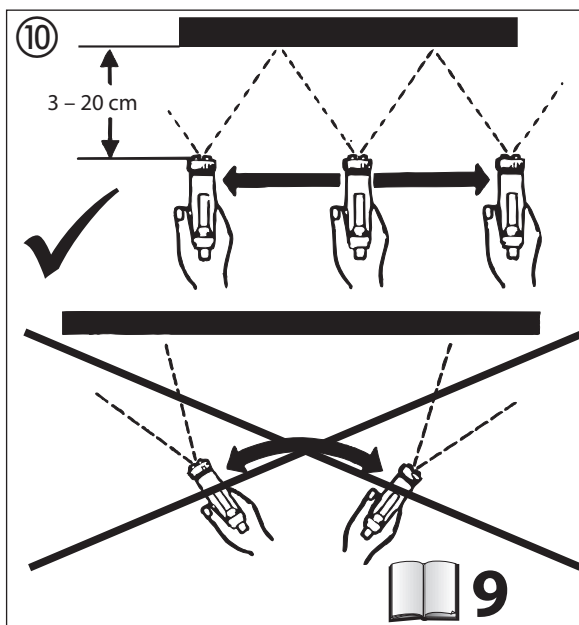
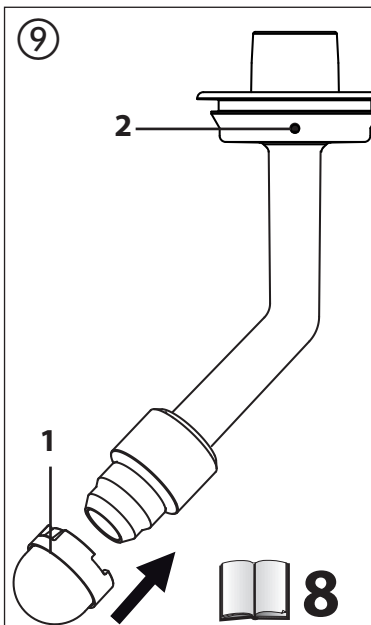
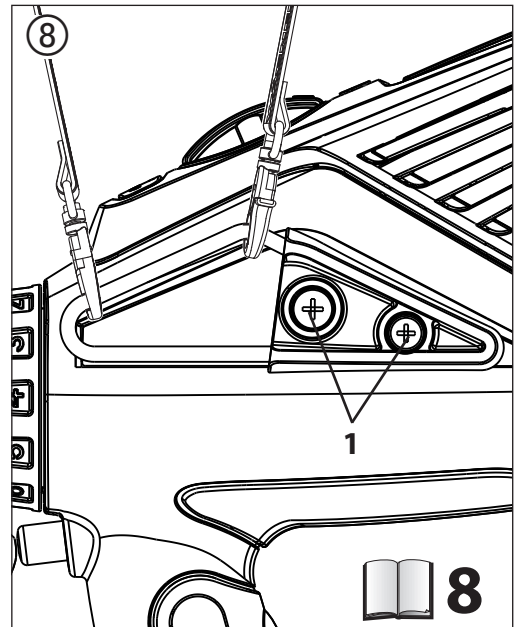
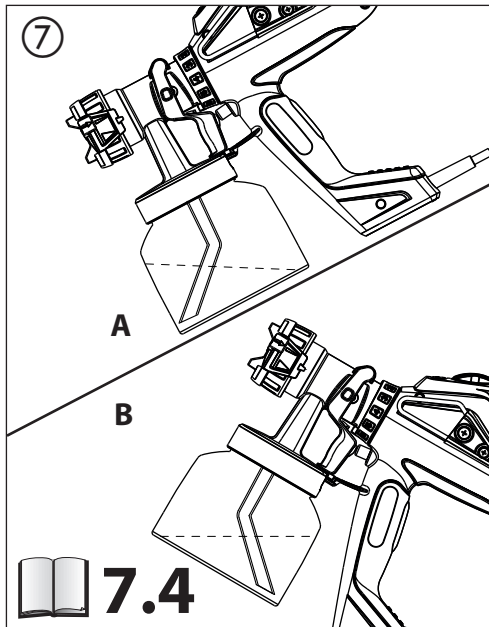
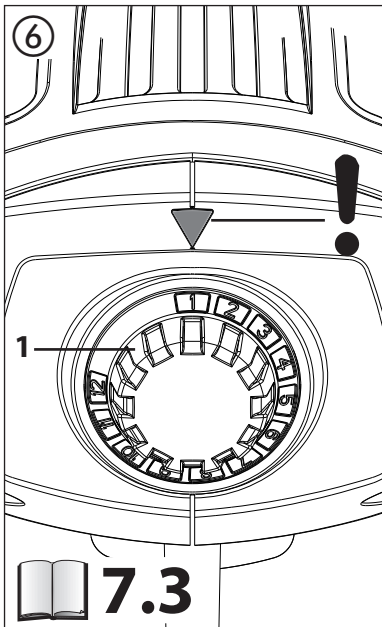
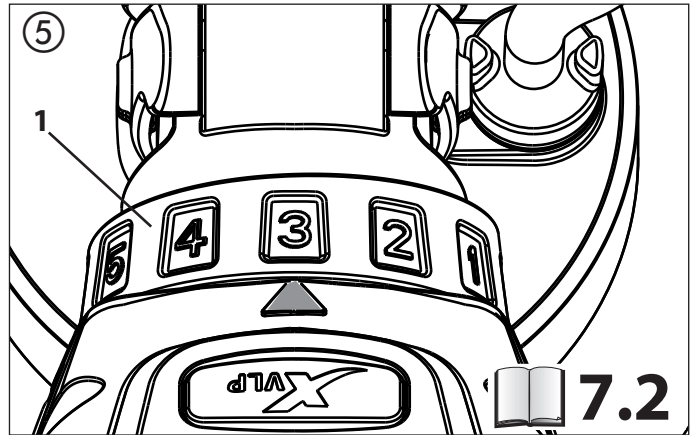
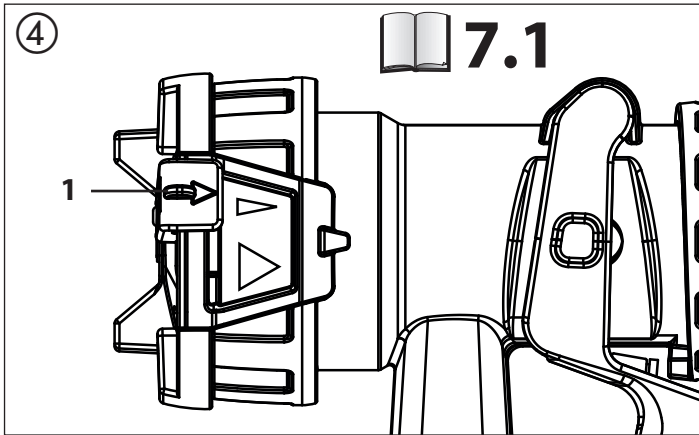

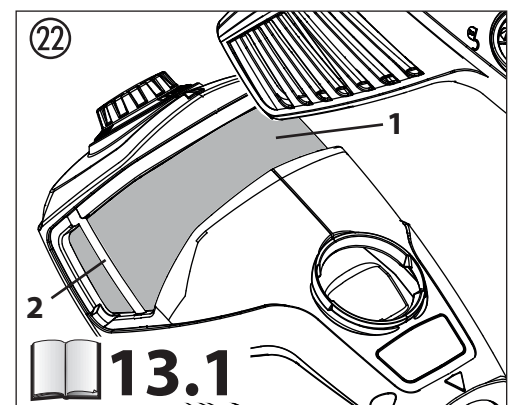
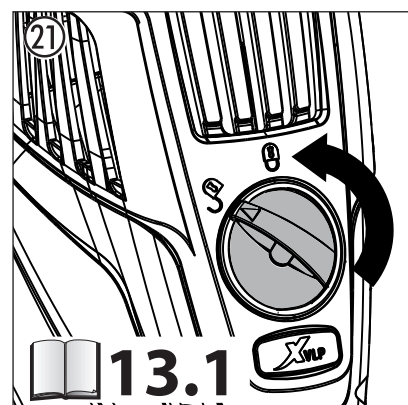
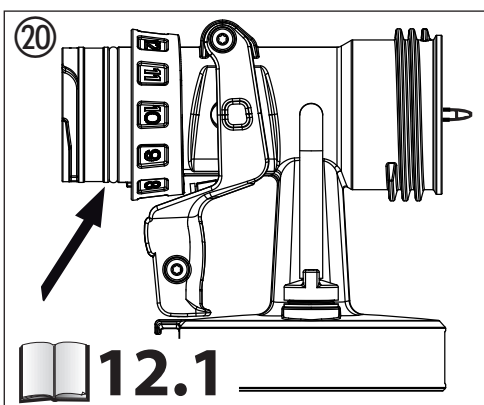
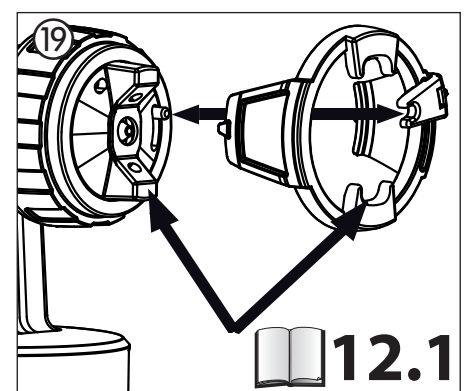
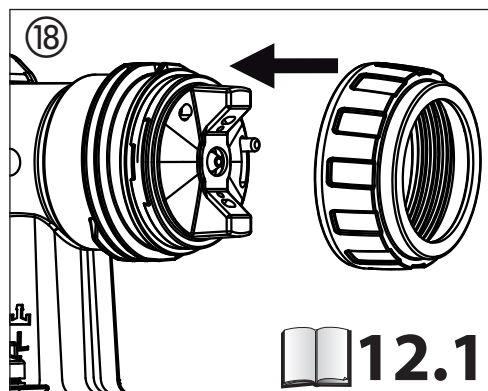
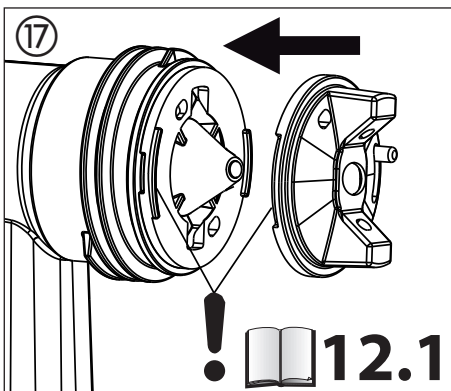
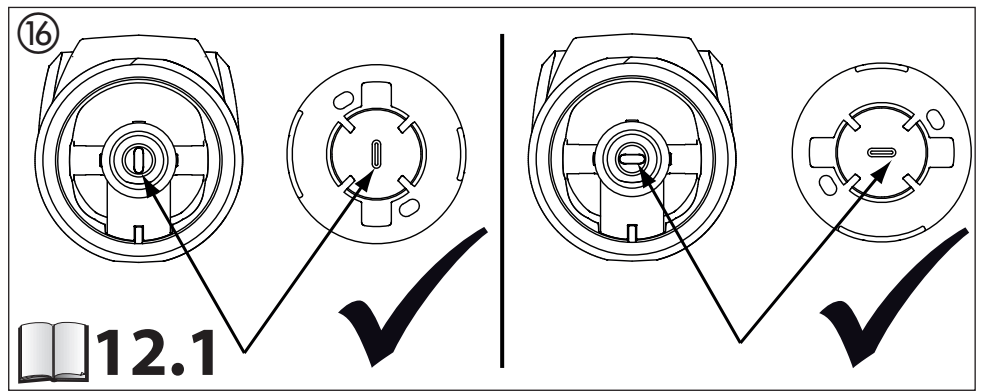
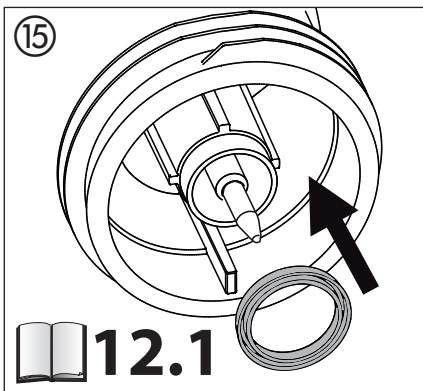
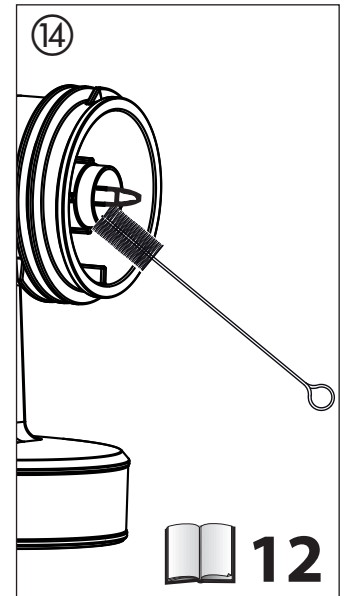
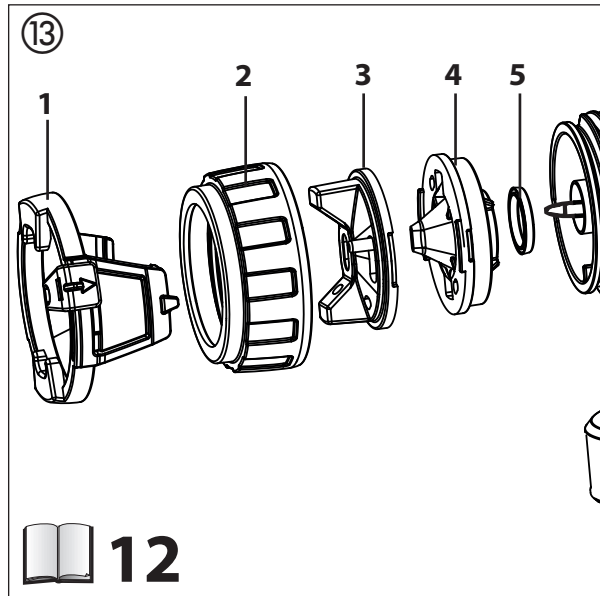
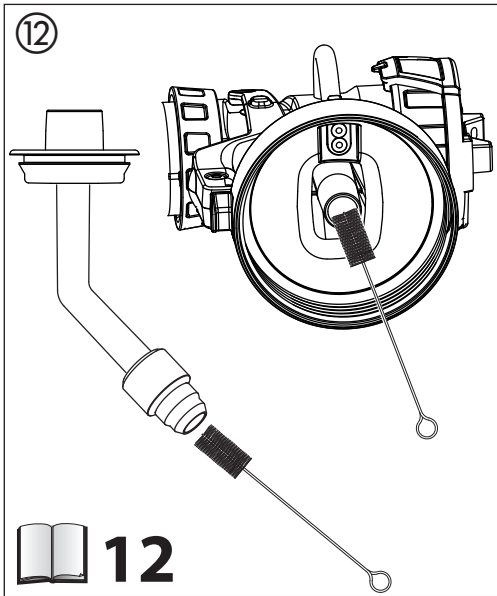

# FinishControl 3500

**WAGNER**

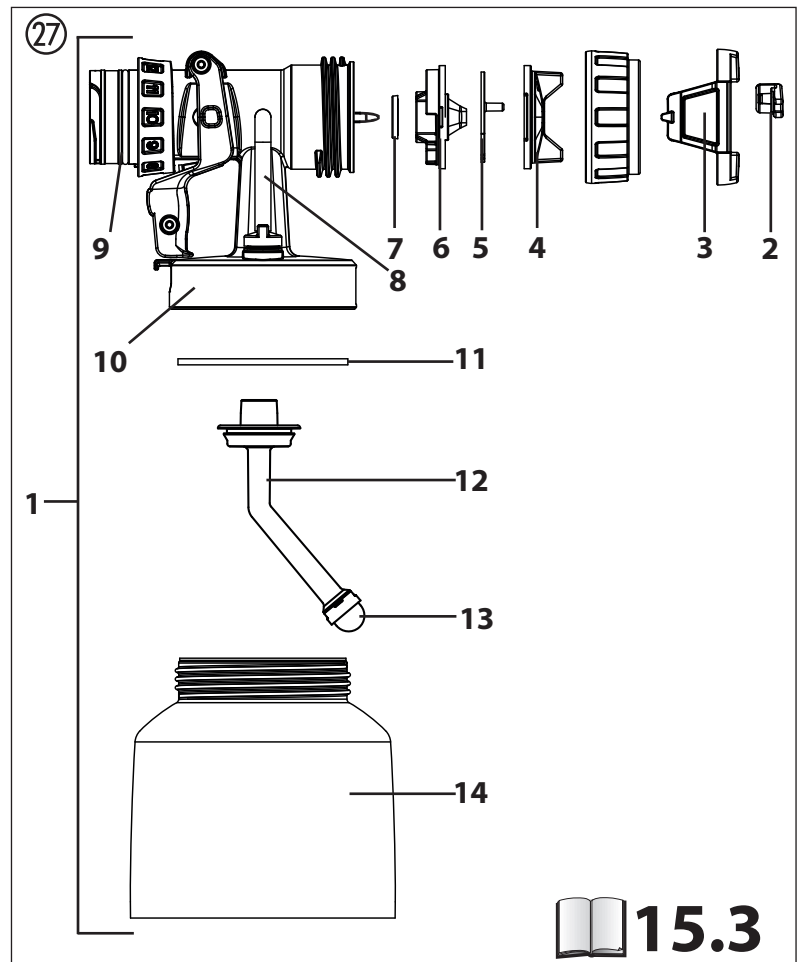
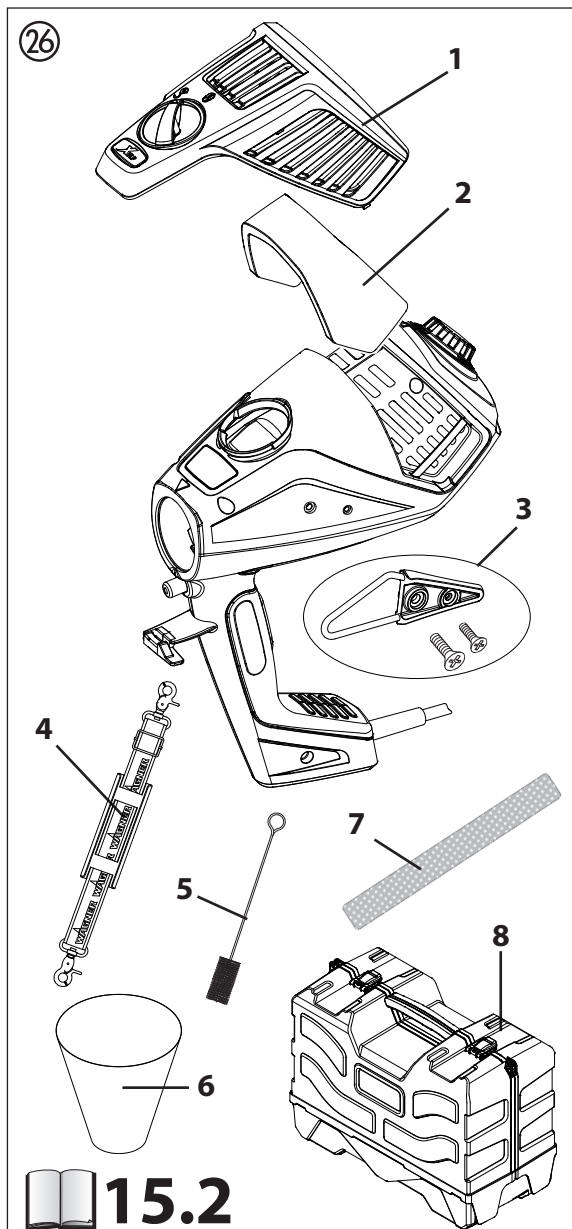
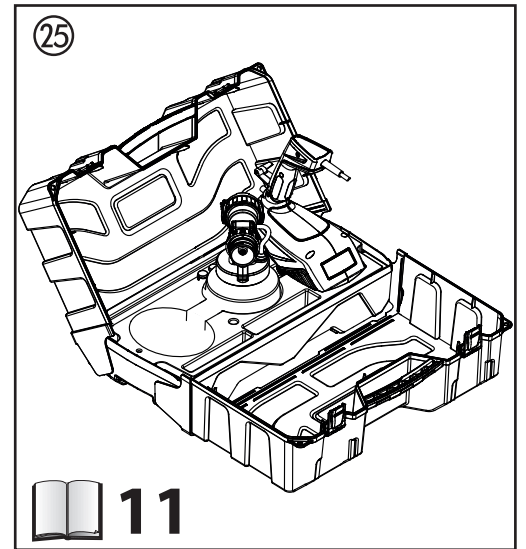
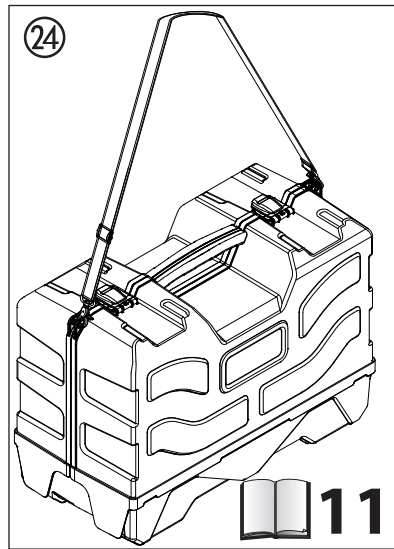
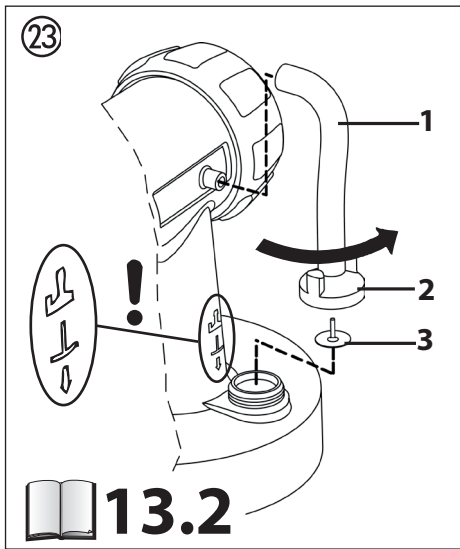

# 目录

1	安全规定	1
2	说明图	3
3	瓦格纳尔CLICK&PAINT系统	3
3.1	喷枪拆卸	3
4	技术数据	4
5	使用XVLP程序喷涂简介	4
6	涂料	4
6.1	适合使用的涂料	4
6.2	不适合使用的涂料	4
6.3	仅由相关喷壶组件 ( 附件 ) 处理的涂料	4
6.4	涂料的准备	4
7	喷枪设置	5
7.1	规定喷雾形状设置	5
7.2	材料用量设置	5
7.3	空气量设置	5
7.4	进料管对准	5
8	启动操作	5
9	喷涂技巧	6
10	工间停顿	6
11	运输	6
12	取出清洗	6
12.1	组装	7
13	维护	7
13.1	空气过滤器	7
13.2	放气阀	7
14	故障校正	8
15	附件和备件	9
15.1	附件	9
15.2	FINISHCONTROL 3500的备件	9
15.3	精细喷壶组件的备件	10
	设备测试	11
	处置说明	11
	产品责任方面的重要信息	11
	质保声明	11
	服务网络	26

## 使用的符号解释

	本符号表示可能对您和设备构成危险。在本符号处有如何避免对设备造成损伤和损坏的重要信息。
	表示提示信息和其他非常有用的信息。
	参阅本使用说明书中的相关章节以及那里所包含的针对插图的信息。
	宽喷幅喷涂射流设置
	窄喷幅喷涂射流设置

# 1 安全规定

必须遵循现行的所有当地安全法规的要求。

仔细阅读操作说明，遵循其中的规定，避免风险。

## 1. 工作场所安全

- a) 保持工作场所清洁，有良好的照明。  
工作场所混乱或无照明可能会引起事故。
- b) 禁止在有易燃液体、气体或粉尘的危险区域内使用工具。  
电动工具会产生火花，可能点燃粉尘或蒸气。
- c) 使用电动工具时，要求儿童和其他人员远离现场。  
注意力不集中时，可能无法控制好工具。
- e) 避免姿势不自然。  
这确保您能在意外情况下更好地控制工具。
- f) 穿着适当衣服。禁止穿宽松衣服或佩戴首饰。保持头发、衣服和手套远离活动零部件。  
宽松衣服、首饰或长头发可能被活动零部件卡住。
- g) 本设备不适合身体、感官或心理能力欠佳或缺乏相关经验和知识的人（包括儿童）使用，除非其在能对其安全负责的人监督下遵循产品说明书进行操作。  
应监督儿童不把玩本设备。

## 2. 电气安全

- a) 工具插头必须装到插座中。插头不能进行任何形式的改装。禁止将转换接头随保护接地工具一起使用。  
未经改装的插头和适当的插座将减少触电危险。
- b) 避免与管道、发热元件、炉和冰箱等接地表面进行身体接触。  
身体接地会增加触电危险。
- c) 保持设备防雨防潮。  
水渗入电气设备会增加触电危险。
- d) 禁止误用电源线引出线，比如用引出线携带工具、用引出线悬挂工具或拉引出线来拔掉插头。保持引出线远离热源、油、锐边或移动的工具零部件。  
引出线受损或缠绕会增加触电危险。
- e) 户外使用电动工具时，只能使用适合户外使用的延长电缆。  
使用适合户外使用的延长线会减少触电危险
- f) 如不得不在潮湿环境使用工具，请使用残余电流断路器。  
使用残余电流断路器可避免触电危险。
- 4. 电动工具的小心轻放和使用
- a) 禁止超载使用本工具。使用其设计适合正在开展的作业的电动工具。  
使用适当电动工具时，在规定性能范围内，作业效果更佳、更安全。
- b) 禁止使用其开关有缺陷的电动工具。  
无法打开或关闭的电动工具具有危险性，必须进行维修。
- c) 进行工具设置、更换附件或收好工具前，必须将插头拔离插座。  
本预防措施可防止工具意外启动。
- d) 请存放好不使用的工具，确保不被儿童接触到。禁止让不熟悉本工具或未阅读本使用说明的人员使用本工具。  
无经验人员使用本工具将会带来危险。
- e) 适当保护好工具。检查活动部件是否能无故障运行，而且不卡住，零部件是否破损或损坏而影响本工具功能。  
使用前，请维修好本工具的受损部件。很多电动工具事故均由于维护欠佳。

## 3. 人员安全

- a) 集中注意力。注意正在进行的作业，并合理使用电动工具。如感觉疲惫或在药品、酒精或药物治疗作用下，请勿使用本工具。  
使用工具时，稍不留神将可能引起严重伤害。
- b) 穿戴好个人安全设备，并一直戴好护目镜。  
根据电动工具类型，穿戴好防尘面具、防滑安全鞋、安全头盔或护耳等个人防护装备将减少受伤危险。
- c) 避免意外启动。将插头插入插座前，确保开关处于“关”位。  
当手指放在开关上或将电动工具接到打开的电源时，携带电动工具可能发生意外事故。
- d) 接通电动工具电源前，搬开设置工具或扳手。  
位于旋转工具零部件上的工具或扳手可能引起受伤。
- 5. 服务
- a) 必须由合格的专门人员，采用原厂备件对工具进行维修。  
这确保能维持工具的安全性。
- b) 为了避免安全隐患，必须由制造商或其服务代理或类似的合格人员更换受损电源线。

## 涂料施工设备的安全使用说明

### 1. 火灾和爆炸危险

在喷涂可燃涂料时以及自动形成涂料蒸汽和稀释剂蒸汽时，在作业区域中将会形成可燃气体（危险区）。在此危险区中的火源具有造成火灾和爆炸的危险。电动喷涂机自身具有潜在火源（电动机开关时、电网插头插入和拔出时以及喷枪处的潜在静电都会导致产生火花）

-> 设备不允许用于适用防爆条例的车间。

-> 禁止使用可燃涂料和清洁剂->请对产品数据表加以注意！

-> 设备附近的涂料桶和溶剂桶必须始终密封。

-> 在采用可燃溶剂清洗设备时，必须先使设备与电网断开，然后采用刷子和抹布进行彻底清洁。在重新投入使用前请确保不再具有残留溶剂。使经清洗的零件完全晾干。

### 2. 警告：受伤危险！

禁止将喷枪对准自己、他人或动物。

### 3. 喷涂时，请穿戴好呼吸设备。

使用者应配备呼吸面罩。为了避免职业病，准备、操作和清洁设备时，必须遵循所使用的材料、溶剂和清洁剂制造商所提供的操作说明。穿戴好防护服、手套，必要时使用护肤霜来保护皮肤。

### 4. 注意：在室内或者露天采用喷漆系统进行作业时必须注意：在喷漆系统区域内不可形成任何含溶剂的蒸汽。在室内进行作业时，必须保证具有足够的通风条件，以将溶剂蒸汽排出。

### 5. 警告：本设备并非防水设备。禁止在室外雨天或在喷洒水或浸在液体中的条件下使用本设备。禁止在潮湿环境中使用本设备。

### 6. 注意！禁止在喷嘴密封件缺失、受损或者安装错误的情况下使用设备。在喷嘴密封件缺乏、受损或者安装错误情况下，液体可能会进入设备，从而会使触电风险增大。在每次使用前请对喷嘴密封件进行检查。

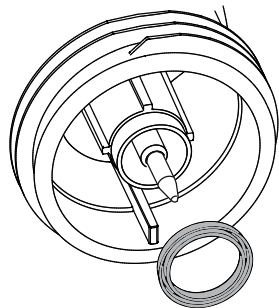

7. 设备的单向阀必须工作正常。如通风软管（图1项目19）中的油漆上升，禁止进一步操作设备。拆卸、清洁通风软管、阀门和隔膜，必要时，更换隔膜。
8. 禁止将填充了油漆的喷枪倒下放置。
9. 按照当地法规要求，现场使用排风系统。
10. 将要进行涂层施工的物体必须接地。
11. 注意所喷涂物质可能产生的危险，遵循容器上的文本和信息要求以及物质制造商所提供的规范要求。
12. 禁止喷涂任何具有未知潜在危险的液体。
13. 拆卸喷壶组件前，打开容器进行泄压。
14. 使用设备前，将电源插头拔离插座。
15. 即使操作说明中有使用或维修说明，但只能由专业电工使用和维修电气设备。不对安装不当承担任何责任。



## 2 说明图 ( 图1 )

位置	名称	位置	名称
1	喷嘴	15	容器
2	枪帽	16	吸料管
3	喷雾射流宽度调节杆 ( 成形空气调节 )	17	容器密封装置
4	喷涂面调节环 ( 垂直/水平 )	18	阀门
5	锁紧螺母	19	通风软管
6	成套喷壶组件	20	清洁刷
7	材料用量调整	21	细进料管过滤器 ( 红色 )
8	背带扣		粗进料管过滤器 ( 白色 )
9	空气过滤器盖锁紧机构	22	漏斗 ( 3件 )
10	空气过滤器盖	23	备用空气过滤器 (3件)
11	空气量控制装置	24	背带 ( 用于设备和便携箱 )
12	电力电缆	25	便携箱
13	Click&Paint搭扣	26	用于固定电缆的扎带
14	扳机 ( 启动涡轮机启动开关 → 输送材料 )		

## 3 WAGNER CLICK&PAINT系统

在瓦格纳Click&Paint系统中，可快捷方便地更换喷枪前部（喷壶组件）。因此可以在不要求清洁的条件下，快速更换材料，并确保各材料和施工均有正确工具。

提供下列喷壶组件：

喷壶组件	适用范围
标准喷涂 ( 黄色 ) 订单号 2330165	槽型喷嘴和1000 毫升不锈钢容器的喷壶组件。可处理所有标准油漆。
精细喷涂 ( 棕色 ) 订单号 2330167	带圆形喷嘴和1000 毫升不锈钢容器的喷壶组件。低粘度油漆和釉料的理想之选。
墙漆喷涂 ( 白色 ) 订单号 2330164	槽型喷嘴和1400 毫升塑料容器的乳胶漆喷壶组件。设计用乳胶漆喷涂。

### 3.1 喷枪拆卸

为了进行装配，请将喷头放入FC 3500，并使两个箭头相互对准。然后将FC 3500朝箭头方向旋转90°，直到听到卡住的声音。（插图2）拆卸喷壶组件时，按下扳机下的搭扣（图2、A），将喷壶组件转动90°。

## 4 技术数据

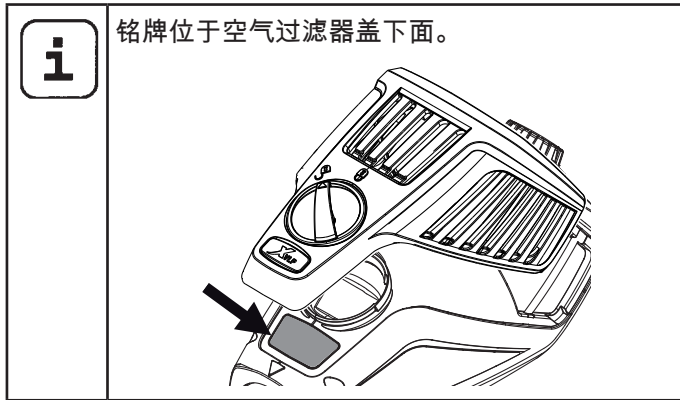

电压：	220 V~, 50 Hz
功耗：	670 W
雾化输出：	220 W
喷壶容积：	1000 毫升
电力电缆：	4 米
保护等级：	I
声压级：* 不确定度K：	74 dB (A) 4 dB (A)
声压输出：* 不确定度K：	87 dB (A) 4 dB (A)
震动水平： 不确定度K：	<2,5 m/s <sup>2</sup> 1,5 m/s <sup>2</sup>
重量 ( 电动鼓风机、和喷枪 )：	2,3 kg

\* 噪音标准符合EN 50144-2-7:2000

## 5 使用XVLP程序喷涂简介

XVLP ( 超大流量低气压 ) 喷涂为一种使用高空气量和低气压的低压喷涂技术。本喷涂技术的最大优点为低漆雾，将过喷降到最低，从而达到节约油漆的目的。与传统涂层施工不同的是，本方式能实现非常经济的完美表面质量，同时有利于环保。

### 功能说明

喷漆系统由一个电动风机组成，它将提供雾化空气。使用喷枪中部分雾化空气对容器增压。该压力将涂料通过吸收管送到喷嘴，在喷嘴处，由其余的雾化空气将涂料雾化。

可直接在喷枪上方方便地进行所有必要的操作设置 ( 如调整油漆量 )。

### 应用领域

FC 3500是为面积不超过50平方米的中小型项目设计的。

## 6 涂料

### 6.1 适合使用的涂料

溶剂型和水溶性清漆  
媒染剂、釉料、浸渍剂、油剂、透明清漆、合成瓷漆、色漆、醇酸树脂清漆、底漆、散热漆、锤纹瓷漆、防锈漆、特效漆、质感漆

### 6.2 不适合使用的涂料

含有高磨料成分、幕墙油漆、苛性碱溶液和酸性涂层物质的材料。可燃涂料

### 6.3 仅由相关喷壶组件 ( 附件 ) 处理的涂料

内墙油漆 ( 乳液和乳胶漆 )

### 6.4 涂料的准备

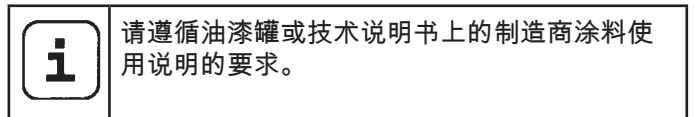

### 涂料清洁度：

精细喷涂系统的无故障操作的绝对先决条件为涂料无杂质。如对涂料纯度有任何疑问，最好先用细筛进行过滤。

采用FineSpray喷头 ( 棕色 ) 处理涂料

涂料	处理	备注
溶剂型清漆	按照制造商使用说明的要求	
水溶性清漆	按照制造商使用说明的要求	
媒染剂、釉料、浸渍剂、油剂	未稀释	使用红色进料管过滤器
透明清漆、合成瓷漆、色漆、醇酸树脂清漆	按照制造商使用说明的要求	
底漆、散热漆、锤纹瓷漆	按照制造商使用说明的要求	
防锈漆、特效漆	按照制造商使用说明的要求	
多彩漆、质感漆	按照制造商使用说明的要求	建议采用Wall-Spray喷壶组件 ( 白色 )

## 7 喷枪设置

### 7.1 喷雾形状设置

	<b>注意：</b> 调节枪帽设置值时，禁止扣动扳机。
--	--------------------------------

通过转动黑色调节环（图3、1），确定喷雾射流的对准。

- A 水平平面射流** → 用于垂直表面
- B 垂直平面射流** → 用于水平表面

还可通过调节杆（图4、1）在宽喷雾射流（▷）和紧凑喷雾射流（▷）间切换。

### 7.2 材料用量设置（图5）

通过转动材料用量控制装置（图5、1），从1（最少）到12（最多）增加材料用量。

### 7.3 空气量设置（图6）

顺时针转动空气量控制装置（图6、1）增加空气量，或逆时针减少空气量（注意喷枪主体上的箭头）。

	正确调节空气和涂料量对于雾化、漆雾形成和工作速度十分关键。
--	-------------------------------

### 7.4 进料管对准

如进料管位于正确位置，可喷射容器内的油漆，几乎无残余。

- 对横卧的物体进行作业时：  
向前转动进料管（图7A）。
- 对高架物体进行喷涂作业时：  
向后转动进料管（图7B）。

## 8 开始操作

连接到主电源前，确保电源电压与标牌上的工作电压对应。设备必须连接到具有适当接地的防电击插座。

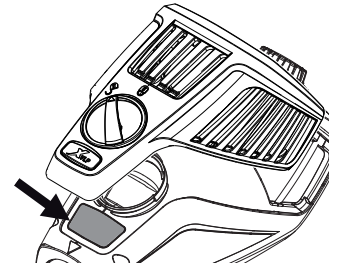

1. 旋开容器。
2. 倒入已经准备好的涂料。

	<p>最多在壶中加入1000毫升。</p>
--	-----------------------

3. 根据使用的涂料，将适当过滤器装到进料管（图9、1）。
  - 低粘度涂料 → 细过滤器（红色）
  - 粘稠涂料 → 粗过滤器（白色）
4. 校准虹吸管。（插图7）
5. 将容器牢固地旋进喷壶组件。
6. 使喷头和FC 3500相互连接。（插图2）

	我们建议在工作时采用一同交付的背带将FC 3500挂着。这样就能使FC3500的重量得到很好地分布，并能使工作变得轻松。
--	--

7. 将背带的两个搭扣固定在背带扣上。（插图8）

	根据需要也可将背带扣安装在FC 3500的另一侧。在此要将两个大小不同的螺栓拧下（插图8.1）。将背带扣安装在另一侧，为此要将螺栓安装在匹配的孔中。注意，只能使用一同交付的螺栓。采用长度或直径错误的螺栓可能会导致设备受损。绝对不能在无背带扣的情况下拧紧螺栓。
--	---

8. 连接电力电缆。
9. 设备现在已经做好运行准备。

## 9 喷涂技术



FinishControl3500具有一个带两个压力点的扳机。在第一级启动涡轮机。继续按下扳机将输送材料。

操作喷枪上的扳机。

在硬纸板上进行试喷涂，确保喷雾形状、喷雾射流宽度、材料和空气量的正确设置。

直立握住喷枪，与正在喷涂的物体保持3-20 cm的恒定距离。（图10）

左右或上下均匀移动喷枪。如均匀移动喷枪，将产生均匀表面效果。

通常在远离物体的地方开始喷涂，避免当仍然在物体上时停止喷涂。

如形成过量漆雾，分别调整控制和材料流量，并改变离物体的距离。

## 10 工间停顿

1. 将电网插头拔下。
2. 如果停顿时间较长，请通过短时间打开喷壶并重新将其关闭来对喷壶进行排气。
3. 在工作中断后请对喷嘴口进行清洁。



在使用快干型或者双组分型涂料时，必须在处理时间内采用合适的清洁剂冲洗设备，否则要花费很大的工作量才能清洁设备，甚至可能造成设备损坏。

## 11 运输



注意！为了放在便携箱子中搬运，加有涂料的喷壶必须处于封闭状态。如果在箱子中具有喷壶，请勿将箱子侧放。

1. 将背带从设备上取下，并将其固定在箱子上（插图24）
2. 如插图25所示，将FC3500和附件装进箱子，并采用橡皮筋固定。



将箱盖左右内侧向外压，以使便携箱的箱盖完全翻起。

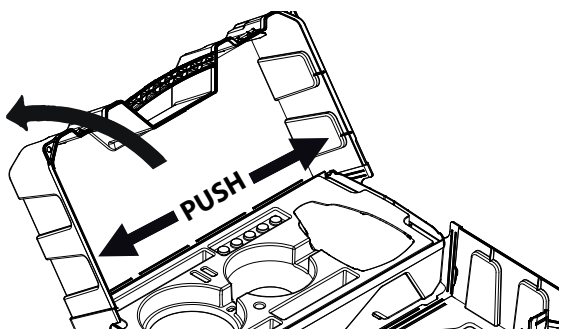

## 12 取出清洗



为了确保正常使用，每天都必须对FC3500进行彻底清洁。

1. 将锁扣（插图2，A）轻轻地向下压。将喷头和涡轮朝相对方向转动并使它们相互分离。



注意！喷枪后面部分绝对不可放在水中或者浸入液体中。只能采用浸湿的软布清洁设备。

2. 旋开容器。  
将剩余的涂料倒入原来的容器中。
3. 用刷子和适当的清洁剂提前清洁好容器和进料管。  
清洁通风孔（图9、2）。
4. 将不可燃的溶剂或者水加入喷壶。将喷壶旋紧。  
请勿喷洒可燃物用于清洁。



在采用可燃溶剂清洗设备时，必须先使设备与电网断开，然后采用刷子和抹布进行彻底清洁。在重新投入使用前请确保不再具有残留溶剂。使经清洗的零件完全晾干。

5. 连接喷壶组件和喷枪手柄。（图2）
6. 拉动扳机并将喷头冲洗干净。  
重复以上程序，直到喷嘴流出清澈的溶剂或水为止。
7. 将电网插头拔下并将喷枪分开。
8. 旋开容器，并将其倒空。  
旋开带容器密封装置的进料管。（图11）
9. 用清洁刷清洁喷壶组件中的进料管和吸嘴。（图12）



注意！禁止用金属物体清洁密封装置、隔膜和喷嘴或喷枪的气孔。  
通风软管仅能在有限范围内耐受溶剂作用。禁止浸没在溶剂中，只能擦拭。

10. 仔细从锁紧螺母（2）处拆下调节环（图13、1）。  
旋下锁紧螺母（2），拆下枪帽（3）、喷嘴（4）和喷嘴密封装置（5）。  
彻底清洁所有零部件。



清洁针头上的空隙时应特别注意。（图14）

11. 用浸泡了溶液或水的布清洁喷枪和容器外部。
12. 重新组装零部件（请参看“组装”）。

## 12.1 组装

	注意！请完全遵循下列所述的组装步骤要求，否则可能损坏喷壶组件。
	注意！禁止在喷嘴密封件缺失、受损或者安装错误的情况下使用设备。在喷嘴密封件缺乏、受损或者安装错误情况下，液体可能会进入设备，从而会使触电风险增大。

1. 将喷嘴密封装置推到针头上，使开槽指向喷壶组件的相反方向。（图15）
2. 将喷嘴设置在针头上，使凹槽向下。  
使用墙面喷涂装置或标准喷涂装置时，请注意：  
针头位置必须适合喷嘴孔径。（图16）
3. 将枪帽设置在喷嘴（注意枪帽中的凹槽）。（图17）
4. 旋紧锁紧螺母。（图18）
5. 将调节环扣到锁紧螺母中。（图19）  
确保调节环上的两处凹槽在枪帽固定装置中啮合，喷雾射流宽度调节杆位于销上。
6. 从下面将容器密封装置设置到进料管上，然后卡箍上滑动，同时稍微转动容器密封装置。
7. 将带容器密封装置的进料管旋进喷枪主体中。

	为了方便喷枪安装，请在清洁后在喷头O型圈上涂上大量润滑油脂（已随设备一同交付）（插图20）。
--	--

## 13 维护

### 13.1 空气过滤器

	注意！禁止在空气过滤器受污染或无空气过滤器的情况下操作设备，因为这可能吸尘，从而影响设备运行。 开始作业前，通常应检查空气过滤器。
--	--

1. 拔下电源插头。
2. 对空气过滤器嵌板的盖解锁 （插图21）并将其取下。
3. 根据受污程度，清洁（吹干净）或更换空气过滤器（图22.1）。
4. 将干净的空气过滤器推到左右两侧的支架下（插图22，2）（请对空气过滤器和嵌板的形状加以注意）。
5. 将空气过滤器嵌板的盖重新装入并加以锁定

### 13.2 放气阀

	如油漆进入风管，请按照下列步骤操作：
--	--------------------

1. 从喷枪主体处拉开顶部的通风软管（图23、1）。旋开阀盖（2）。取下隔膜（3）。仔细清洁所有零部件。

	注意！通风软管和隔膜仅能在有限范围内耐受溶剂作用。禁止浸没在溶剂中，只能擦拭。
--	---

2. 将隔膜设置在阀盖中，使销朝前（请参看喷枪主体上的标记）。
3. 将喷枪主体倒置，从底部旋紧阀盖。
4. 将通风软管设置在阀盖上和喷枪主体的喷嘴上。

## 14 故障排除

故障	原因	修复
设备无法启动	<ul style="list-style-type: none"> <li>•无电源电压</li> </ul>	<ul style="list-style-type: none"> <li>•检查</li> </ul>
喷嘴无法喷出涂料	<ul style="list-style-type: none"> <li>•喷嘴堵塞</li> <li>•缺料</li> <li>•油漆容器密封装置受损</li> <li>•容器内无压力上升</li> <li>•容器排空</li> <li>•通风软管松脱/受损</li> <li>•进料管松脱</li> <li>•进料管/进料管过滤器堵塞</li> <li>•进料管上的气孔堵塞</li> <li>•隔膜卡住</li> <li>•隔膜放反了</li> </ul>	<ul style="list-style-type: none"> <li>•清洁</li> <li>•增加材料</li> <li>•更换</li> <li>•拧紧容器</li> <li>•重新装油漆</li> <li>•插紧或更换</li> <li>•插紧</li> <li>•清洁或更换过滤器</li> <li>•清洁</li> <li>•拆卸并清洁 ( 请参看第13.2节 )</li> <li>•将隔膜正确放入 ( 请参看第13.2节 )</li> </ul>
喷嘴处有涂料滴漏	<ul style="list-style-type: none"> <li>•枪帽、喷嘴或针头受污</li> <li>•喷壶组件组装不正确</li> <li>•喷嘴松脱</li> <li>•缺乏喷嘴密封件或者已磨损</li> <li>•喷嘴磨损</li> <li>•针头磨损</li> </ul>	<ul style="list-style-type: none"> <li>•清洁</li> <li>•正确组装 ( 请参看第12.1节 )</li> <li>•拧紧锁紧螺母</li> <li>•装入完好无损的喷嘴密封件</li> <li>•更换</li> <li>•使用新的喷壶组件</li> </ul>
雾化过粗	<ul style="list-style-type: none"> <li>•出料过多</li> <li>•喷嘴受污</li> <li>•涂料粘度过高</li> <li>•容器内压力上升过小</li> <li>•空气过滤器严重受污</li> <li>•空气量过低</li> </ul>	<ul style="list-style-type: none"> <li>•减少出料量</li> <li>•清洁</li> <li>•进一步稀释</li> <li>•拧紧容器</li> <li>•更换 ( 请参看第13.1节 )</li> <li>•增加出气量</li> </ul>
喷雾射流有脉冲	<ul style="list-style-type: none"> <li>•缺料</li> <li>•喷嘴密封装置磨损</li> <li>•空气过滤器严重受污</li> <li>•进料管松脱</li> <li>•进料管/进料管过滤器堵塞</li> </ul>	<ul style="list-style-type: none"> <li>•重新装油漆</li> <li>•更换</li> <li>•更换 ( 请参看第13.1节 )</li> <li>•插紧</li> <li>•清洁或更换过滤器</li> </ul>
被喷涂物体上涂料向下流淌	<ul style="list-style-type: none"> <li>•喷涂了过量涂料</li> <li>•距离过近</li> <li>•喷壶组件不正确</li> </ul>	<ul style="list-style-type: none"> <li>•减少用量</li> <li>•增加距离</li> <li>•使用其他喷壶组件</li> </ul>
过量漆雾 ( 过喷 )	<ul style="list-style-type: none"> <li>•离物体距离过大</li> <li>•喷涂了过量涂料</li> <li>•空气量过高</li> <li>•涂料过度稀释</li> <li>•喷壶组件不正确</li> <li>•错误的喷涂技术</li> </ul>	<ul style="list-style-type: none"> <li>•减少距离</li> <li>•减少用量</li> <li>•减少用量</li> <li>•降低稀释度</li> <li>•使用其他喷壶组件</li> <li>•有关正确喷涂技术的信息见第9章</li> </ul>
通风软管中有油漆	<ul style="list-style-type: none"> <li>•隔膜受污</li> <li>•隔膜有缺陷</li> </ul>	<ul style="list-style-type: none"> <li>•清洁隔膜 ( 请参看第13.2节 )</li> <li>•更换隔膜 ( 请参看第13.2节 )</li> </ul>

## 15 附件和备件

### 15.1 附件

位置	订单编号	名称
1	2330 165	StandardSpray喷壶组件 (黄色) (带1000 ml容器) 用于所有标准油漆处理。
2	2330 167	FineSpray喷壶组件 (棕色) (带1000 ml容器) 低粘度油漆和釉料的理想之选。
3	2330 164	WallSpray喷壶组件 (白色) (带 1400 ml 容器) 为乳液处理而设计。
4	2324 749	带盖容器 (1400 ml)



不可将可加热喷壶TempSpray与FC 3500一起使用。

### 15.2 FINISHCONTROL 3500的备件 (图26)

位置	订单编号	名称
1	2343 946	空气过滤器舱盖
2	2343 947	空气过滤器 (3件)
3	2343 948	背带扣 (包括螺栓)
4	2341 187	背带
5	0514 209	清洁刷
6	2324 745	漏斗 (3件)
7	2344 041	用于固定电缆的扎带
8	2341 100	便携箱
9	2360 395	喷枪的后面部分 (包括位置1-3)

## 15.3 FINESPRAY喷壶组件 (棕色) 的备件 (图27)

位置	订单编号	名称
1	2330 167	精细喷壶组件 (棕色), 带1000 毫升容器
2	2321 868	喷雾射流宽度调节杆
3	2314 591	喷雾射流调节环
4	2332 579	锁紧螺母 (棕色)
5	2317 820	枪帽
6	2314 585	空气滤网
7	2317 667	喷嘴 (R 1.8)
8	2323 934	喷嘴密封装置
9	2304 027	通风软管、阀盖、隔膜
10	0417 308	喷壶组件的O型环
11	2326 126	喷枪主体 (包括位置8-10)
12	2319 223	容器密封装置
13	2319 222	进料管
14	2324 248	细进料管过滤器 (红色、5件)
	2324 249	粗进料管过滤器 (白色、5件)
15	2322 451	1000 ml的带盖容器
	2315 539	润滑脂



## 设备试验

为了安全，建议至少每12个月，按照规定，由专家对设备进行检查，确保设备能继续安全运行。

如设备不使用，可在重新启动前，推迟检查。

同时必须遵循所有（可能有所差异）国家检验和维护法规的规定。

如有问题，请联系瓦格纳尔的顾客服务团队。

## 产品责任方面的重要信息

1990年1月1日起生效的欧盟指令规定，只有在所有零部件均由制造商制造或批准，且设备正确安装和操作的条件下，制造商方对其产品承担质量责任。

如采用第三方附件或备件，不适用部分或全部质量责任。

在极端情况下，主管部门可能禁止全套设备的使用（德国工业雇主责任保险协会和工厂检查员）。

瓦格纳尔公司原厂附件和备件保证符合所有安全法规的规定。

## 处置说明

遵循废弃电气和电子设备方面的2002/96/EC号欧盟指令和按照国家法律的规定实施时，本产品不得随家庭垃圾一起处置，必须以环保方式进行回收利用！



瓦格纳尔公司或公司经销商会回收用过的瓦格纳尔废弃电气或电子设备，并以环保方式帮您处置此类设备。详情请联系当地瓦格纳尔服务中心或经销商或直接与我们联系。

## 质保声明

( 01.02.2009 )

### 1. 质保范围

所有瓦格纳尔专业涂料应用设备（以下简称为“产品”）均经仔细检验试验，并经瓦格纳尔质量保证严格检查。瓦格纳尔公司只向在授权专门店购买产品的用户提供质量保证。

本质保不损害顾客就购买协议上的不合格产品向卖方提出质量责任提出索赔的权利及其法定权利。

公司对有产品质量问题的设备，免费进行维修产品或更换零部件。公司承担材料和工作时间成本。被更换产品或零部件为本公司所有。

### 2. 保质期和注册登记

本产品质量保证期为12个月。

保质期自授权专门店发货之日起，以原始购买文件上的日期为准。

确认质保证书和具有购买日期的质保证书或原始购买发票有效。

如按照质保要求进行维护时，产品的质保期不延长或续期。

一旦质保期到期，对质保提出索赔或按照质保要求提出索赔均不生效。

### 3. 搬运

如在质保期内发现设备的材料、加工或性能方面有缺陷，应立即提出质保索赔，且最迟不超过2周。

交付设备的授权专门店有权接受质保索赔。还可以对公司操作说明书中指定的服务中心提出质保索赔。产品发送或提交均不收取费用，并提供具有购买日期和产品名称详情的原始购买文件。

运输过程产生的，或接受质保索赔或交付已修理的产品的服务中心造成的产品丢失或受损的成本和风险均由顾客承担。

### 4. 质保的例外规定

下列情况不考虑提供质保：

- 因使用而造成磨损或其他自然磨损的零部件，以及因自然磨损或因使用而造成磨损而产生产品缺陷的零部件。特别包括电缆、阀门、包装、喷嘴、缸体、活塞、载重的外壳部件、过滤器、管道、密封装置、转子、定子等。特别由于乳液、灰泥、油灰、粘合剂、釉料、石英基础等砂涂料引起的磨损而造成的损坏。

- 由于未遵循操作说明书的要求、不适当或非专业使用、顾

## 质保声明

客或第三方不正确组装和/或调试、或用于规定外使用目的、不正常环境条件、不适当涂料、不适当工作条件、使用不正确电源电压/频率、过度操作或不正确维护或护理和/或清洁而引起设备出错。

- 使用非瓦格纳尔原厂的附件、其他零部件或备件而引起设备出错。
- 进行改装或加装的产品。
- 序列号不见或难以辨认的产品。
- 由未经授权人员修理过的产品。
- 与目标属性稍有偏差的产品，这些偏差对设备价值和可用性可忽略不计。
- 部分或全部拆开的产品。

## 5. 其他规定

上如检查发现非担保情况，顾客应承担修理费用。

上述规定规定了客户与本公司的法律关系。因产品或其使用而引起的其他索赔，尤其是任何类型的损坏和损失，不在产品质量保证范围内，但涉及适用范围的例外。

因产品缺陷而向专门商家提出索赔的不受影响。

德国法律适用本担保。合同文件使用德语。如本担保的德文和英文文本意义有冲突，以德文文本的意义为准。

Wagner Spraytech(shanghai) Co., Ltd.  
Division Professional Finishing  
No.1228, Wanrong Road  
200436, Shanghai, China

Subject to modifications

## Contents

<b>1</b>	<b>SAFETY REGULATIONS</b>	<b>14</b>
<b>2</b>	<b>EXPLANATORY DIAGRAM</b>	<b>16</b>
<b>3</b>	<b>THE WAGNER CLICK&amp;PAINT SYSTEM</b>	<b>16</b>
3.1	Disassembly of the spray gun	16
<b>4</b>	<b>TECHNICAL DATA</b>	<b>17</b>
<b>5</b>	<b>INTRODUCTION TO SPRAYING USING THE XVLP PROCEDURE</b>	<b>17</b>
<b>6</b>	<b>COATING MATERIAL</b>	<b>17</b>
6.1	Coating Materials Suitable for Use	17
6.2	Coating Materials Not Suitable for Use	17
6.3	Coating materials that can only be processed with relevant spray attachment (accessories)	17
6.4	Preparing the coating material	17
<b>7</b>	<b>SETTING THE SPRAY GUN</b>	<b>18</b>
7.1	Setting the required spray pattern	18
7.2	Setting the amount of material	18
7.3	Setting the amount of air	18
7.4	Align the feed tube	18
<b>8</b>	<b>STARTING OPERATION</b>	<b>18</b>
<b>9</b>	<b>SPRAYING TECHNIQUE</b>	<b>19</b>
<b>10</b>	<b>BREAKS IN WORK</b>	<b>19</b>
<b>11</b>	<b>TRANSPORTATION</b>	<b>19</b>
<b>12</b>	<b>TAKING OUT OF OPERATION AND CLEANING</b>	<b>19</b>
12.1	Assembly	20
<b>13</b>	<b>MAINTENANCE</b>	<b>20</b>
13.1	Air filter	20
13.2	Air relief valve	20
<b>14</b>	<b>CORRECTION OF MALFUNCTIONS</b>	<b>21</b>
<b>15</b>	<b>ACCESSORIES AND SPARE PARTS</b>	<b>22</b>
15.1	Accessories	22
15.2	Spare parts FinishControl 3500	22
15.3	Spare Parts FineSpray spray attachment	23
	Testing of the unit	24
	Note on disposal	24
	Important information on product liability	24
	Guarantee declaration	24
	Service network	26

### Explanation of symbols used

	<b>This symbol indicates a potential danger for you or for the device. Under this symbol you can find important information on how to avoid injuries and damage to the device.</b>
	<b>Indicates tips for use and other particularly useful information.</b>
	<b>Refers to the corresponding chapter in the operating manual and the information presented there relating to the illustration.</b>
	<b>Wide spray jet setting</b>
	<b>Narrow spray jet setting</b>

## 1 SAFETY REGULATIONS

All local safety regulations in force must be observed.

Read the operating instructions carefully and follow the instructions laid down in them in order to avoid risks.

### 1. Safety at the workplace

- a) **Keep your workplace clean and well lit.**  
*Disorder or unlit workplaces may result in accidents.*
- b) **Never use the tool in hazardous areas that contain flammable liquids, gases or dusts.** *Power tools generate sparks that can ignite the dust or vapors.*
- c) **Keep children and other persons away when using the power tool.** *You can lose control of the tool if you are distracted.*

### 2. Electrical Safety

- a) **The tool plug must fit into the socket. The plug may not be modified in any form. Do not use adaptor plugs together with protective-earthed tools.**  
*Unmodified plugs and suitable sockets reduce the risk of an electric shock.*
- b) **Avoid physical contact with earthed surfaces such as pipes, heating elements, stoves and refrigerators.**  
*The risk through electric shock increases if your body is earthed.*
- c) **Keep the equipment away from rain and moisture.**  
*The risk of an electric shock increases if water penetrates electrical equipment.*
- d) **Do not misuse the mains lead by carrying the tool by the lead, hanging it from the lead or by pulling on the lead to remove the plug. Keep the lead away from heat, oil, sharp edges or moving tool parts.**  
*Damaged or twisted leads increase the risk of an electric shock.*
- e) **If you work outdoors with a power tool, only use extension cables suitable for outdoor use.** *The use of an extension lead that is suitable for outdoors reduces the risk of an electric shock.*
- f) **If you cannot avoid using the tool in a damp environment, use a residual current operated circuit-breaker.** *Using a residual current operated circuit-breaker avoids the risk of electric shock.*

### 3. Safety of Persons

- a) **Be attentive. Pay attention to what you are doing and work sensibly with a power tool. Do not use the tool if you are tired or under the influence of drugs, alcohol or medication.** *Just a moment of inattentiveness while using the tool can lead to serious injuries.*

b) **Wear personal safety equipment and always wear safety goggles.** *Wearing personal protective equipment, such as dust mask, non-slip safety shoes, safety helmet or ear protection, depending on the type of power tools, reduces the risk of injury.*

c) **Avoid accidental starting-up. Ensure that the switch is in the "OFF" position before inserting the plug into the socket.** *Accidents can occur if you carry the power tool while your finger is on the switch or if you connect the power tool to the power supply which it is on.*

d) **Remove setting tools or wrenches before switching on the power tool.** *A tool or wrench that is in a rotating tool part can lead to injuries.*

e) **Avoid an unnatural posture.** *This ensures that you can control the tool better in unexpected situations.*

f) **Wear suitable clothing. Do not wear wide clothing or jewellery. Keep your hair, clothes and gloves away from moving parts.** *Loose clothing, jewellery or long hair can be caught in moving parts.*

g) **This appliance is not intended for use by persons (including children) with reduced physical, sensory or mental capabilities, or lack of experience and knowledge, unless they have been given supervision or instruction concerning use of the appliance by a person responsible for their safety.** *Children should be supervised to ensure that they do not play with the appliance.*

### 4. Careful Handling and Use of Power Tools

- a) **Do not overload the tool. Use the power tool designed for the work that you are doing.** *You work better and safer in the specified performance range if you use the suitable power tool.*
- b) **Do not use power tools whose switch is defective.** *A power tool that cannot be switched on or off is dangerous and has to be repaired.*
- c) **Remove the plug from the socket before carrying out tool settings, changing accessories or putting the tool away.** *This precautionary measure prevents unintentional starting of the tool.*
- d) **Store unused power tools so that they are inaccessible to children. Do not let persons use the tool who are not familiar with it or who have not read these instructions.** *Power tools are dangerous when they are used by inexperienced persons.*
- e) **Take proper care of your tools. Check whether the moving parts function trouble-free and do not jam, whether parts are broken or damaged so that the tool function is impaired.** *Have damaged parts repaired before using the tool. Many accidents have their origin in power tools that have been maintained badly.*
- f) **Use the power tool, accessories, insert tools, etc. in accordance with these instructions and in a fashion specified for this special tool type. Take the working conditions and the activity to be carried out into consideration.** *The use of power tools for purposes other than the intended ones can lead to dangerous situations.*

## 5. Service

- a) **Have your tool repaired only by qualified specialist personnel and only with original spare parts.** *This ensures that the tool safety is maintained.*
- b) **If the supply cord is damaged, it must be replaced by the manufacturer or it's service agent or a similarly qualified person in order to avoid a safety hazard.**

## Safety instructions for colour application devices

### 1. Risks of Fire and Explosion

When spraying flammable coatings vapours from paint and solvents can cause flammable gases to be produced in the work area (hazard area).

Risk of fire and explosion due to ignition sources in this danger zone.

The electrically operated spray device contains potential ignition sources (spark formation when switching the motor on and off, when inserting and removing the power plug, due to potential static electricity at the spray gun)

-> **Device must not be used at operating sites that fall under the explosion protection ordinance.**

-> **Do not use combustible coating substances and cleaning agents -> observe product data sheets!**

-> **Always seal paint or solvent containers tightly in the vicinity of the device.**

-> **When cleaning devices with flammable solvents, disconnect the device from the mains and clean thoroughly with a brush and cloth. Before starting the device up again, ensure that all traces of solvents are removed thoroughly. Allow the cleaned parts to dry completely.**

### 2. Warning: Danger of injury!

**Never point spray gun at yourself, other persons or animals.**

### 3. When spraying paint wear a suitable respirator.

The user should be supplied with a breathing mask. In order to avoid occupational diseases, the working instructions provided by the manufacturer of the materials, solvents and cleaning agents used must be complied with during preparation, working with and cleaning the equipment. Protective clothing, gloves and, if necessary, protective skin cream is required to protect the skin.

- 4. **Warning: When working with the paint spraying system both indoors and outdoors, ensure that no solvent-based vapours can form within the area of the paint spraying system. When working in closed places a sufficient ventilation must be ensured to remove the solvent vapours.**

- 5. **Warning: The device is not splash proof. It should not be used, neither outdoors in the rain nor be sprayed with water nor immersed in liquid. Do not use the device in damp or wet environments.**

- 6. **Attention! Never operate the device if the nozzle seal is missing, damaged or incorrectly mounted. If the nozzle seal is either missing, damaged or incorrectly mounted liquids can enter the device and increase the risk of an electric shock. Check the nozzle seal before each use.**

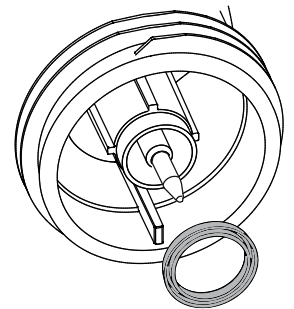

- 7. The units may only be used with a functional valve. If paints rises in the ventilating hose (Fig. 1, item 19) do not operate the unit further! Dismantle and clean the ventilating hose, valve and diaphragm and replace the diaphragm if necessary.
- 8. Do not lay the filled spray gun down.
- 9. Extraction systems should be installed on-site according to the local regulations.
- 10. The object to be coated must be earthed.
- 11. Caution against dangers that can arise from the sprayed substance and observe the text and information on the containers or the specifications given by the substance manufacturer.
- 12. Do not spray any liquid of unknown hazard potential.
- 13. Before dismantling the spray attachment, relieve pressure by opening the container.
- 14. **Before working on the device, remove the power plug from the socket.**
- 15. Work or repairs on the electrical equipment should only be carried out by a professional electrician, even if there are instructions regarding such work in the operating instructions. No liability will be accepted for improper installation.

## 2 EXPLANATORY DIAGRAM (FIG. 1)

POS.	DESIGNATION	POS.	DESIGNATION
1	Nozzle	15	Container
2	Air cap	16	Suction tube
3	Spray jet width adjusting lever (shaping air)	17	Container seal
4	Spray jet level adjusting ring (vertical/horizontal)	18	Valve
5	Union nut	19	Ventilating hose
6	Spray attachment complete	20	Cleaning brush
7	Material volume regulation	21	Fine feed tube filter (red) Coarse feed tube filter (white)
8	Fixture for shoulder strap	22	Funnel (3 pcs.)
9	Air filter cover lock	23	Replacement air filter (3 pcs.)
10	Air filter cover	24	Carrying strap (for device and transport case)
11	Air volume control	25	Transport case
12	Power cable	26	Velcro to secure the power cable
13	Click&Paint catch		
14	Trigger (actuates turbine starting switch → material is conveyed)		

## 3 THE WAGNER CLICK&PAINT SYSTEM

With the Wagner Click&Paint System, the front part of the gun (spray attachment) can be replaced quickly and easily. This enables a rapid material change without cleaning, and ensures that the right tool is available for every material and application.

The following spray attachments are available:

Spray attachment	Area of application
StandardSpray (yellow) Order No. 2330165	Spray attachment with slit nozzle and 1000 ml stainless steel container. Processes all standard paints.
FineSpray (brown) Order No. 2330167	Spray attachment with round nozzle and 1000 ml stainless steel container. Ideal for low-viscosity paints and glazes.
WallSpray (white) Order No. 2330164	Dispersion spray attachment with slit nozzle and 1400 ml plastic container. Designed for processing dispersions and latex paint.

### 3.1 DISASSEMBLY OF THE SPRAY GUN

For assembly, insert the spray attachment into the FC 3500 so that the two arrows point at each other. Turn the FC 3500 90° in the arrow direction until it audibly engages. (Fig. 2)

To remove the spray attachment, push the catch (Fig. 2, A) beneath the trigger down and turn the spray attachment by 90°.

## 4 TECHNICAL DATA

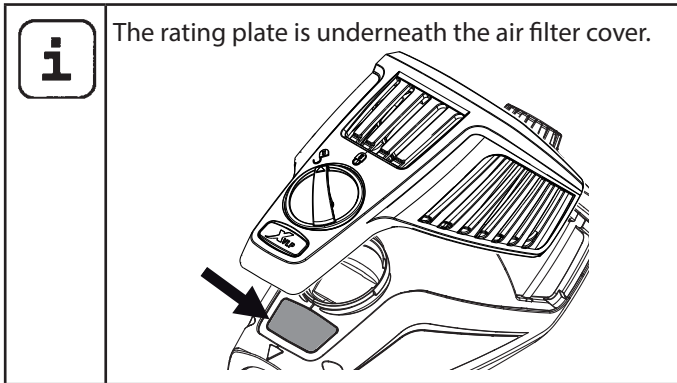

Voltage:	220 V~, 50 Hz
Power consumption:	670 W
Atomizing output:	220 W
Container volume:	1000 ml
Power cable:	4 m
Protection class:	I
Sound pressure level:*	74 dB (A)
Uncertainty K:	4 dB (A)
Sound pressure output:*	87 dB (A)
Uncertainty K:	4 dB (A)
Oscillation level:	<2.5 m/s <sup>2</sup>
Uncertainty K:	1.5 m/s <sup>2</sup>
Weight (motor-operated blower and spray gun):	2.3 kg

\* The acoustic emission value was ascertained in accordance with EN 50144-2-7:2000

## 5 INTRODUCTION TO SPRAYING USING THE XVLP PROCEDURE

XVLP (**Extra Volume Low Pressure**) is a low pressure spraying technique, which works with a high volume of air and a low air pressure. The greatest advantage of this spraying technique is the low paint mist formation. This reduces the amount required to cover the object to a minimum.

As opposed to conventional application of coatings, this method achieves a highly economical and perfect surface quality and is, at the same time, environmentally friendly.

### Function description

The paint spraying system consists of a motor-operated turbo-blower, which provides the spray gun with atomisation air. In the spray gun, a part of the atomisation air is used to pressurise the container. This pressure causes the coating material to be fed through the uptake pipe to the nozzle where it is

atomised by the rest of the atomisation air. All settings necessary for operation (e.g. material volume) can be conveniently made, directly on the gun.

### Field of application

The FC 3500 is designed for smaller to medium-sized projects, i.e. for surfaces of a **maximum of 50 m<sup>2</sup>**.

## 6 COATING MATERIAL

### 6.1 COATING MATERIALS SUITABLE FOR USE

Solvent-based and water-soluble lacquer paints  
Mordants, glazes, impregnations, oils, clear varnishes, synthetic enamels, coloured paints, alkyd resin varnishes, primers, radiator paints, hammer effect enamels, anti-rust paints, special-effect paints, textured paints

### 6.2 COATING MATERIALS NOT SUITABLE FOR USE

Materials that contain highly abrasive components, facade paint, caustic solutions and acidic coating substances.  
Flammable materials.

### 6.3 COATING MATERIALS THAT CAN ONLY BE PROCESSED WITH RELEVANT SPRAY ATTACHMENT (ACCESSORIES)

Interior wall paint (dispersions and latex paint)

### 6.4 PREPARING THE COATING MATERIAL

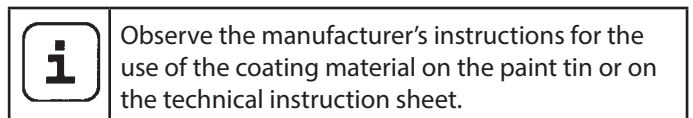

### Coating material purity:

An absolute pre-condition for the trouble-free operation of the fine-spray system is that the coating material is uncontaminated. If you have doubts as to the purity of the coating material, we recommend that you first filter it through a fine sieve.

### Processing the coating material with the FineSpray spray attachment (brown)

Coating Material	Processing	Comments
Solvent-based lacquer paints	observe manufacturer's instructions	
Water-soluble lacquer paints	observe manufacturer's instructions	
Mordants, glazes, impregnations, oils	undiluted	Use red feed tube filter

Clear varnishes, synthetic enamels, coloured paints, alkyd resin varnishes	observe manufacturer's instructions	
Primers, radiator paints, hammer effect enamels	observe manufacturer's instructions	
Anti-rust paints, special-effect paints	observe manufacturer's instructions	
Multicolor paints, textured paints	observe manufacturer's instructions	WallSpray spray attachment (white) recommended

## 7 SETTING THE SPRAY GUN

### 7.1 SETTING THE REQUIRED SPRAY PATTERN

	<b>Attention:</b> Never pull trigger while adjusting the air cap settings.
--	---

The alignment of the spray jet can be determined by turning the black adjusting ring (Fig. 3, 1).

- A horizontal flat jet** → for vertical surfaces
- B vertical flat jet** → for horizontal surfaces

It is also possible to switch between a wide (▶) and a compact (▷) spray jet with the adjusting lever (Fig. 4, 1).

### 7.2 SETTING THE AMOUNT OF MATERIAL (FIG. 5)

The material volume can be adjusted incrementally from 1 (minimum) to 12 (maximum) by turning the material volume control (Fig. 5, 1).

### 7.3 SETTING THE AMOUNT OF AIR (FIG. 6)

Turn the air volume control (Fig. 6, 1) clockwise to increase the air volume or anti-clockwise to reduce the air volume (note arrow on body of gun).

	Setting the air and paint flow rate correctly is important for atomisation, overspray and working speed.
--	--

### 7.4 ALIGN THE FEED TUBE

If the feed tube is positioned correctly, the container contents can be sprayed without almost any residue. When working on lying objects: Turn the feed tube forwards. (Fig. 7 A) Spraying work when working on overhead objects: Turn the feed tube rearwards. (Fig. 7 B)

## 8 STARTING OPERATION

Before connecting to the mains supply make sure that the mains voltage corresponds to the operating voltage on the rating plate. The unit must be connected with a properly earthed shock-proof socket.

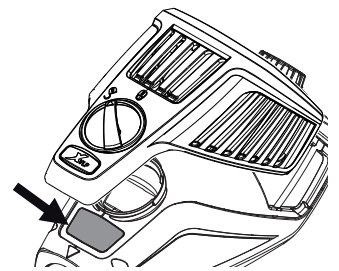

1. Unscrew the container from the spray attachment.
2. Pour in the prepared coating material.

	Fill the container with maximum 1000 ml.	1000ml →
--	--	----------

3. Fit the appropriate filter to the feed tube depending on the coating material used (Fig. 9, 1)
  - Low-viscosity coating materials → Fine filter (red)
  - Viscous coating materials → Coarse filter (white)
4. Align the feed tube. (Fig. 7)
5. Screw the container firmly onto the spray attachment.
6. Connect spray attachment and FC 3500. (Fig. 2)

	When working with the FC 3500 we recommend using the supplied carrying strap. This enables the weight of the FC 3500 to be better distributed and the work can be carried out with less effort.
--	---

7. Both carabiner locks on the carrying strap have to be secured to the fixture. (Fig. 8)

	The fixture for the carrying strap can be mounted to the other side of the FC 3500 if this is preferred. Do this by unscrewing the two large screws (fig. 8, 1). Mount the fixture to the other side by inserting the screws into the relevant holes. <b>Please make sure that you use only the screws that have been provided. Screws of the wrong length or diameter can damage the device. Never tighten the screws without the fixture.</b>
--	---

8. Plug in the power cable.
9. The device is now ready for operation.



## 9 SPRAYING TECHNIQUE

**i** The FC 3500 has a trigger with 2 pressure points. The turbine is started via the first pressure point. If the trigger is pressed further, the material is transported.

Operate trigger on the spray gun.

Test spray a piece of cardboard to ensure correct setting of the spray pattern, spray jet width, material and air volume.

Hold the paint spray gun upright and maintain a constant distance of about 3 - 20 cm to the object being sprayed. (Fig. 10)

Move the paint spray gun evenly either from side to side or up and down. If the gun is moved evenly, it will produce an even surface finish.

Always start spraying away from the object and avoid stopping spraying whilst still on the object.

In case of excessive paint mist formation, adjust the air and material flow respectively and alter the distance from the object.

## 10 BREAKS IN WORK

1. Unplug the power plug.
2. During longer breaks, vent the container by briefly opening and then closing it again.
3. Clean nozzle openings after an interruption in operation.

**i** In using quick-drying or two-component coating materials, do not fail to rinse unit through with a suitable cleaning agent during the processing period.

## 11 TRANSPORTATION

**!** **ATTENTION! Full containers have to be closed tightly when transported in the case. Do not lie the case on its side if it contains full containers of paint.**

1. Detach the carrying strap from the device and secure it to the case (fig. 24).
2. Put the FC 3500 and accessories inside the case as shown in fig. 25 and secure with elastic straps.

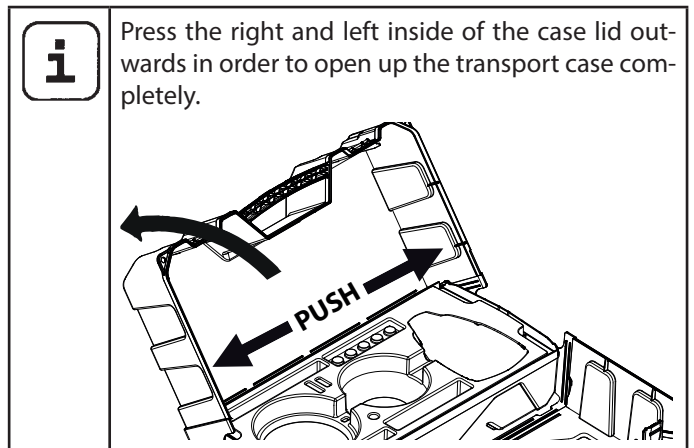

## 12 TAKING OUT OF OPERATION AND CLEANING

**i** In order to ensure smooth operations, the FC 3500 has to be cleaned thoroughly every day.

1. Divide the spray gun. Press catch (Fig. 2, A) down slightly. Twist the spray attachment and turbine in a counter movement to disconnect them from each other.

**!** **ATTENTION! Never hold the spray gun rear part under water or immerse it into liquids. Clean the housing only with a moistened cloth.**

2. Unscrew the container. Empty the remaining coating material into the original container.
3. Pre-clean the container and feed tube using a brush and suitable cleaning agent. Clean the ventilating bore. (Fig. 9, 2)
4. Fill the container with a **non-flammable** solvent or water. Screw the container back on.  
**Do not spray flammable materials for cleaning purposes.**

**!** **When cleaning devices with flammable solvents, disconnect the device from the mains and clean thoroughly with a brush and cloth. Before starting the device up again, ensure that all traces of solvents are removed thoroughly. Allow the cleaned parts to dry completely.**

5. Connect spray attachment and gun handle. (Fig. 2)
6. Pull the trigger to rinse the spray attachment. Repeat the above procedure until the solvent or water emerging from the nozzle is clear.
7. Turn off the machine and divide the spray gun.
8. Screw off the container and empty it. Unscrew feed tube with container seal. (Fig. 11)

9. Clean feed tube and suction nozzle in spray attachment with cleaning brush. (Fig. 12)

	<b>CAUTION! Never clean seals, diaphragm and nozzle or air holes of the spray gun with metal objects. The ventilation hose and diaphragm are only solvent-resistant to a limited extent. Do not immerse in solvent, only wipe.</b>
--	--

10. Remove the adjusting ring (fig. 13,1) carefully from the union nut (2). Unscrew union nut (2), remove air cap (3), nozzle (4) and nozzle seal (5). Thoroughly clean all parts.

	Take special care when cleaning the interstices on the needle (Fig. 14)
--	---

11. Clean the outside of the container with a cloth soaked in solvent or water.  
12. Assemble the parts again (see "Assembly").

### 12.1 ASSEMBLY

	<b>ATTENTION! Follow the steps described below exactly for assembly. Otherwise the spray attachment may be damaged.</b>
--	---

	<b>ATTENTION! Never operate the device if the nozzle seal is missing, damaged or incorrectly mounted. If the nozzle seal is either missing, damaged or incorrectly mounted liquids can enter the device and increase the risk of an electric shock.</b>
--	---



1. Push nozzle seal onto the needle so that the groove (slot) points away from the spray attachment. (Fig. 15)
2. Place nozzle on the needle with recess downwards. **Attention! If using WallSpray or StandardSpray: Position of needle must be congruent with the nozzle aperture. (Fig. 16)**
3. Place air cap on nozzle (pay attention to recesses in the air cap). (Fig. 17)
4. Screw on union nut. (Fig. 18)
5. Snap the adjusting ring into the union nut. (Fig. 19)  
Make sure that the two recesses on the adjusting ring are engaged in the air cap clamps and that the lever for adjusting the spray jet width is located on the pin.
6. Place the container seal from below on the feed tube and slide it over the collar, while turning the container seal slightly.
7. Screw the feed tube with the container seal into the body of the gun.

	In order to mount the gun more easily apply lubricating grease (enclosed) liberally to the O-ring at the spray attachment (Fig. 20).
--	--

## 13 MAINTENANCE

### 13.1 AIR FILTER

	<b>Attention! Never operate the device with the air filter soiled or missing, as dirt could be sucked up and affect the operation of the device. Always check the air filter before starting work.</b>
---	--

1. Unplug the power plug.
2. Release the air filter compartment  (fig. 21) and remove.
3. Clean (blow out) or replace the air filter (Fig. 22,1) depending on the degree of soiling.
4. Push the clean air filter underneath the fixtures (fig. 22, 2) on the left and right-hand sides (pay attention to the shape of the air filter and compartment).
5. Reattach the cover of the air filter compartment and lock .

### 13.2 AIR RELIEF VALVE

	If paint has entered the ventilation hose, proceed as follows:
---	--

1. Pull the ventilating hose (Fig. 23, 1) at the top from the gun body. Screw off the valve cover (2). Remove the diaphragm (3). Clean all the parts carefully.

	<b>CAUTION! The ventilation hose and diaphragm are only solvent-resistant to a limited extent. Do not immerse in solvent, only wipe.</b>
---	--

2. Place the diaphragm in the valve cover with the pin facing forward (Also see the marking on the gun body).
3. Turn the body of the gun upside down and screw on the valve cover from underneath.
4. Place the ventilating hose on the valve cover and on the nipple at the gun body.

## 14 CORRECTION OF MALFUNCTIONS

MALFUNCTION	CAUSE	REMEDY
The unit will not start	<ul style="list-style-type: none"> <li>• No mains voltage</li> </ul>	<ul style="list-style-type: none"> <li>• Check</li> </ul>
No coating material emerges from the nozzle	<ul style="list-style-type: none"> <li>• Nozzle clogged</li> <li>• Material volume setting too low</li> <li>• Paint container seal damaged</li> <li>• No pressure build-up in container</li> <li>• Container empty</li> <li>• Ventilation hose loose/damaged</li> <li>• Feed tube loose</li> <li>• Feed tube / feed tube filter clogged</li> <li>• Air vent on feed tube blocked</li> <li>• Diaphragm stuck</li> <li>• The diaphragm is positioned the wrong way round.</li> </ul>	<ul style="list-style-type: none"> <li>• Clean</li> <li>• Increase volume</li> <li>• Replace</li> <li>• Tighten container</li> <li>• Refill</li> <li>• Insert or replace</li> <li>• Insert</li> <li>• Clean or use another filter</li> <li>• Clean</li> <li>• Remove and clean (see section 13.2)</li> <li>• Position the diaphragm correctly (see section 13.2)</li> </ul>
Coating material drips from the nozzle	<ul style="list-style-type: none"> <li>• Air cap, nozzle or needle soiled</li> <li>• Spray attachment incorrectly assembled</li> <li>• Nozzle loose</li> <li>• Nozzle seal is missing or worn</li> <li>• Nozzle worn</li> <li>• Needle worn</li> </ul>	<ul style="list-style-type: none"> <li>• Clean</li> <li>• Assemble correctly (see section 12.1)</li> <li>• Tighten Union nut</li> <li>• Insert an intact nozzle seal</li> <li>• Change</li> <li>• Use new spray attachment</li> </ul>
Atomisation too coarse	<ul style="list-style-type: none"> <li>• Material volume too large</li> <li>• Nozzle contaminated</li> <li>• Viscosity of coating material too high</li> <li>• Too little pressure build-up in container</li> <li>• Air filter heavily soiled</li> <li>• Amount of air too low</li> </ul>	<ul style="list-style-type: none"> <li>• Reduce volume</li> <li>• Clean</li> <li>• Dilute further</li> <li>• Tighten container</li> <li>• Change (see section 13.1)</li> <li>• Increase volume</li> </ul>
Spray jet pulsates	<ul style="list-style-type: none"> <li>• Coating material in container running out</li> <li>• Nozzle seal is missing or worn</li> <li>• Air filter heavily soiled</li> <li>• Feed tube loose</li> <li>• Feed tube / feed tube filter clogged</li> </ul>	<ul style="list-style-type: none"> <li>• Refill</li> <li>• Insert an intact nozzle seal</li> <li>• Change (see section 13.1)</li> <li>• Insert</li> <li>• Clean or use another filter</li> </ul>
The material runs down the object being painted	<ul style="list-style-type: none"> <li>• Too much coating material applied</li> <li>• Distance too small</li> <li>• Incorrect spray attachment</li> </ul>	<ul style="list-style-type: none"> <li>• Reduce volume</li> <li>• Increase distance</li> <li>• Use another spray attachment</li> </ul>
Excessive paint mist (overspray)	<ul style="list-style-type: none"> <li>• Distance to the object too large</li> <li>• Too much coating material applied</li> <li>• Amount of air too high</li> <li>• Coating substance over-diluted</li> <li>• Incorrect spray attachment</li> <li>• Incorrect spraying technique</li> </ul>	<ul style="list-style-type: none"> <li>• Reduce distance</li> <li>• Reduce volume</li> <li>• Reduce volume</li> <li>• Reduce degree of dilution</li> <li>• Use another spray attachment</li> <li>• For information about the correct spraying technique, please see chapter 9</li> </ul>
Paint in the ventilating hose	<ul style="list-style-type: none"> <li>• Diaphragm soiled</li> <li>• Diaphragm defective</li> </ul>	<ul style="list-style-type: none"> <li>• Clean the diaphragm (see section 13.2)</li> <li>• Replace the diaphragm (see section 13.2)</li> </ul>

## 15 ACCESSORIES AND SPARE PARTS

### 15.1 ACCESSORIES

POS.	ORDER NO.	DESIGNATION
1	2321 165	StandardSpray spray attachment (yellow) (with 1000 ml container) Processes all standard paints.
2	2321 167	FineSpray spray attachment (brown) (with 1000 ml container) Ideal for low-viscosity paints and glazes.
3	2321 164	WallSpray spray attachment (white) (with 1400 ml container) Designed for processing dispersions.
4	2324 749	Container with cover (1400 ml)



The FC 3500 cannot be used with the heatable TempSpray spray attachment.

### 15.2 SPARE PARTS FINISHCONTROL 3500 (FIG. 26)

POS.	ORDER NO.	DESIGNATION
1	2343 946	Cover of air filter compartment
2	2343 947	Air filter (3 pcs.)
3	2343 948	Fixture for shoulder strap (incl. screws)
4	2341 187	Carrying strap
5	0514 209	Cleaning brush
6	2324 745	Funnel (3 pcs.)
7	2344 041	Velcro to secure the power cable
8	2341 100	Transport case
9	2360 395	Spray gun rear part (including position 1-3)

**15.3 SPARE PARTS FINESPRAY SPRAY ATTACHMENT (BROWN) (FIG. 27)**

POS.	ORDER NO.	DESIGNATION
1	2330 167	FineSpray spray attachment (brown) with 1000 ml container
2	2321 868	Spray jet width adjusting lever
3	2314 591	Spray jet adjustment ring
4	2332 579	Union nut (brown)
5	2317 820	Air cap
6	2314 585	Air screen
7	2317 667	Nozzle (R 1.8)
8	2323 934	Nozzle seal
9	2304 027	Ventilating hose, valve cover, diaphragm
10	0417 308	O-ring of spray attachment
11	2326 126	Body of gun (including position 8-10)
12	2319 223	Container seal
13	2319 222	Feed tube
14	2324 248	Fine feed tube filter (red, 5 pc.)
	2324 249	Coarse feed tube filter (white, 5 pc.)
15	2322 451	Container with cover 1000 ml
	2315 539	Lubricating grease

## TESTING OF THE UNIT

For safety reasons, we would recommend having the device checked by an expert as required but at least every 12 months to ensure that it can continue to operate safely.

In the case of unused devices, the check can be postponed until they are next started up.

All (potentially deviating) national inspection and maintenance regulations must also be observed.

If you have any questions, please contact the customer service team at Wagner.

## IMPORTANT INFORMATION ON PRODUCT LIABILITY

An EU directive valid since 01.01.1990 specifies that the manufacturer is only liable for his products if all the parts originate from the manufacturer or are approved by him, and if the units are mounted and operated properly.

If accessories or spare parts from third parties are used, liability can be partially or completely inapplicable. In extreme cases the responsible authorities can prohibit the use of the entire unit (German industrial employer's liability insurance association and factory inspectorate).

With original WAGNER accessories and spare parts, compliance with all safety regulations is guaranteed.

## NOTE ON DISPOSAL

In observance of the European Directive 2002/96/EC on waste electrical and electronic equipment and implementation in accordance with national law, this product is not to be disposed of together with household waste material but must be recycled in an environmentally friendly way!



Wagner or one of our dealers will take back your used Wagner waste electrical or electronic equipment and will dispose of it for you in an environmentally friendly way. Please ask your local Wagner service centre or dealer for details or contact us direct.

## GUARANTEE DECLARATION

(Status 01.02.2009)

### 1. Scope of guarantee

All Wagner professional colour application devices (hereafter referred to as products) are carefully inspected, tested and are subject to strict checks under Wagner quality assurance. Wagner exclusively issues extended guarantees to commercial or professional users (hereafter referred to as "customer") who have purchased the product in an authorised specialist shop, and which relate to the products listed for that customer on the Internet under [www.wagner-group.com/profi-guarantee](http://www.wagner-group.com/profi-guarantee).

The buyer's claim for liability for defects from the purchase agreement with the seller as well as statutory rights are not impaired by this guarantee.

We provide a guarantee in that we decide whether to replace or repair the product or individual parts, or take the device back and reimburse the purchase price. The costs for materials and working hours are our responsibility. Replaced products or parts become our property.

### 2. Guarantee period and registration

The guarantee period amounts to 36 months. For industrial use or equal wear, such as shift operations in particular, or in the event of rentals it amounts to 12 months.

Systems driven by petrol or air are also guaranteed for a 12 month period.

The guarantee period begins with the day of delivery by the authorised specialist shop. The date on the original purchase document is authoritative.

For all products bought in authorised specialist shops from 01.02.2009 the guarantee period is extended to 24 months providing the buyer of these devices registers in accordance with the following conditions within 4 weeks of the day of delivery by the authorised specialist shop.

Registration can be completed on the Internet under [www.wagner-group.com/profi-guarantee](http://www.wagner-group.com/profi-guarantee).

The guarantee certificate is valid as confirmation, as is the original purchase document that carries the date of the purchase. Registration is only possible if the buyer is in agreement with having the data being stored that is entered during registration.

When services are carried out under guarantee the guarantee period for the product is neither extended nor renewed.

Once the guarantee period has expired, claims made against the guarantee or from the guarantee can no longer be enforced.

### 3. Handling

If defects can be seen in the materials, processing or performance of the device during the guarantee period, guarantee claims must be made immediately, or at the latest within a period of 2 weeks.

The authorised specialist shop that delivered the device is entitled to accept guarantee claims. Guarantee claims may also be made to the service centres named in our operating instructions. The product has to be sent without charge or presented together with the original purchase document that includes details of the purchase date and the name of the product. In order to claim for an extension to the guarantee, the guarantee certificate must be included.

The costs as well as the risk of loss or damage to the product in transit or by the centre that accepts the guarantee claims or who delivers the repaired product, are the responsibility of the customer.

### 4. Exclusion of guarantee

Guarantee claims cannot be considered

- for parts that are subject to wear and tear due to use or other natural wear and tear, as well as defects in the product that are a result of natural wear and tear, or wear and tear due to use. This includes in particular cables, valves, packaging, jets, cylinders, pistons, means-carrying housing components, filters, pipes, seals, rotors, stators, etc. Damage due to wear and tear that is caused in particular by sanded coating materials, such as dispersions, plaster, putty, adhesives, glazes, quartz foundation.
- in the event of errors in devices that are due to non-compliance with the operating instructions, unsuitable or unprofessional use, incorrect assembly and/or commissioning by the buyer or by a third party, or utilisation other than is intended, abnormal ambient conditions, unsuitable coating materials, unsuitable operating conditions, operation with the incorrect mains voltage supply/frequency, over-operation or defective servicing or care and/or cleaning.
- for errors in the device that have been caused by using accessory parts, additional components or spare parts that are not original Wagner parts.
- for products to which modifications or additions have been carried out.
- for products where the serial number has been removed or is illegible
- for products to which attempts at repairs have been carried out by unauthorised persons.
- for products with slight deviations from the target properties, which are negligible with regard to the value and usability of the device.
- for products that have been partially or fully taken apart.

### 5. Additional regulations.

The above guarantees apply exclusively to products that have been bought by authorised specialist shops in the EU, CIS, Australia and are used within the reference country.

If the check shows that the case is not a guarantee case, repairs are carried out at the expense of the buyer.

The above regulations manage the legal relationship to us conclusively. Additional claims, in particular for damages and losses of any type, which occur as a result of the product or its use, are excluded from the product liability act except with regard to the area of application.

Claims for liability for defects to the specialist trader remain unaffected.

German law applies to this guarantee. The contractual language is German. In the event that the meaning of the German and a foreign text of this guarantee deviate from one another, the meaning of the German text has priority.

J. Wagner GmbH  
Division Professional Finishing  
Otto Lilienthal Strasse 18  
88677 Markdorf  
Federal Republic of Germany

Subject to modifications

Wagner Spraytech(Shanghai) Co., Ltd.  
Division Professional Finishing  
No.1228, Wanrong Road  
200436, Shanghai, China